

Number of contacts

64, 32

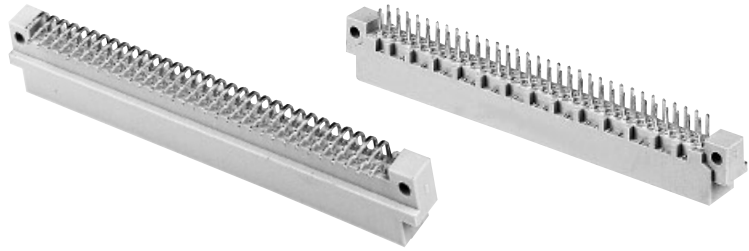

Male connectors

DIN Signal
up to 2 A

Identification	Number of contacts	Contact arrangement	Part No. Performance levels according to IEC 60603-2. Explanation chapter 00		
			3	2	1
Male connector with angled solder pins	64		09 02 164 7921	09 02 164 6921 09 02 164 6921 222 ^{f)} 09 02 364 6921 ^{b)} 09 02 664 6921 ^{c)}	09 02 164 2921
	32		09 02 132 7921	09 02 132 6921 09 02 632 6921 ^{c)}	09 02 132 2921
	32		09 02 132 7931	09 02 132 6931 09 02 332 6931 ^{b)}	09 02 132 2931
	62 + 2 [▲]			09 02 164 6951	
SMC	64		09 02 164 7919 ^{d)}	09 02 164 6919 ^{d)}	
Male connector with straight solder pins	64		09 02 164 7922	09 02 164 6922	09 02 164 2922
	32		09 02 132 7922	09 02 132 6922	
	32			09 02 132 6932	
	62 + 2 [▲]			09 02 164 6952	09 02 164 2952
SMC	64			09 02 164 6920 ^{d)}	

Dimensions

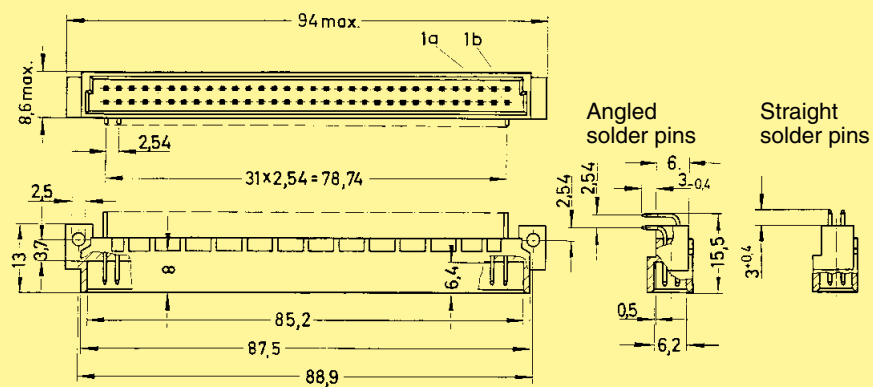

Board drillings

Mounting side

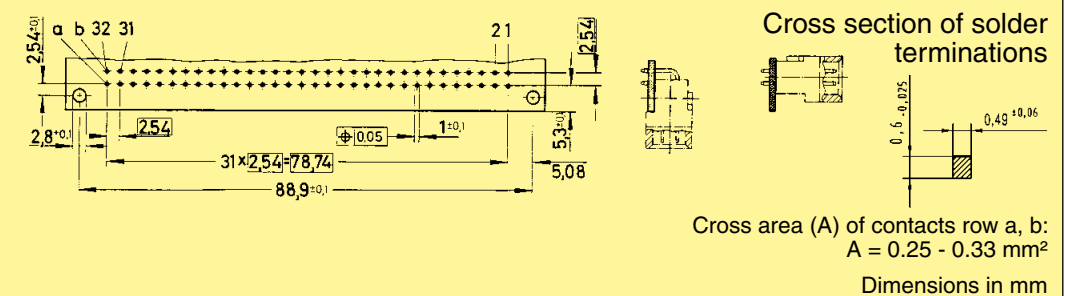

[▲] Male connectors with 2 leading contacts [(0.8 mm) pos. a1 and a32]. Lagging pins on request.
Other contact arrangements on request
^{b)} Connectors with snap-in clips see chapter 00

^{c)} Connectors with coding see chapter 00
^{d)} CTI > 400
^{f)} Railway classification NFF 16-101, Smoke index: F1, Flammability class: I2