

NOTE 1 DIMENSIONS FROM REFERENCE SURFACE A (BOTTOM SURFACE OF HOUSING).
 2 LEAD CO-PLANARITY SHALL BE 0.1 MAX.
 3 LENGTH AFTER FPC IS INSERTED.
 4 $0.3^{+0.04}_{-0.03}$ CAN BE APPLIED WITH LEAD PLATED.
 5 NOTE THAT PREVENTIVE HOLE FOR SINK MARK COULD BE ADDED FOR IMPROVEMENT.
 THE QUALITY REMAINS GOOD, EVEN WITH THE DARK SPOTS, WHICH COULD OCCASIONALLY OCCUR ON MOLDED PLASTIC.

RECOMMENDED FPC(FREE)

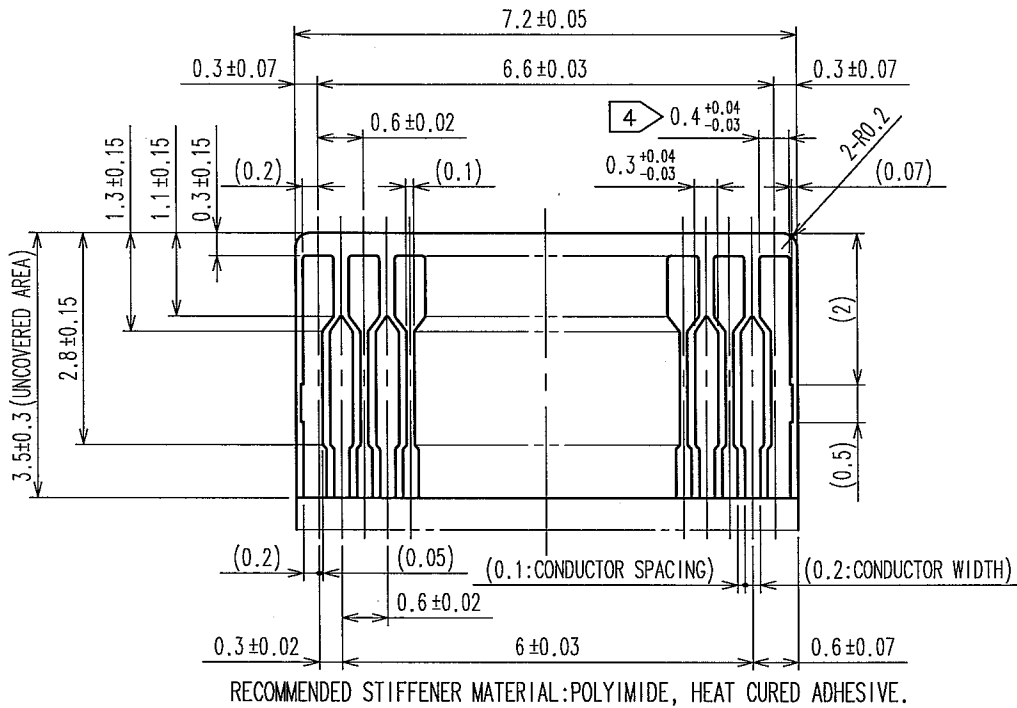

RECOMMENDED STIFFENER MATERIAL: POLYIMIDE, HEAT CURED ADHESIVE.

RECOMMENDED LAND PATTERN, METAL MASK(FREE)

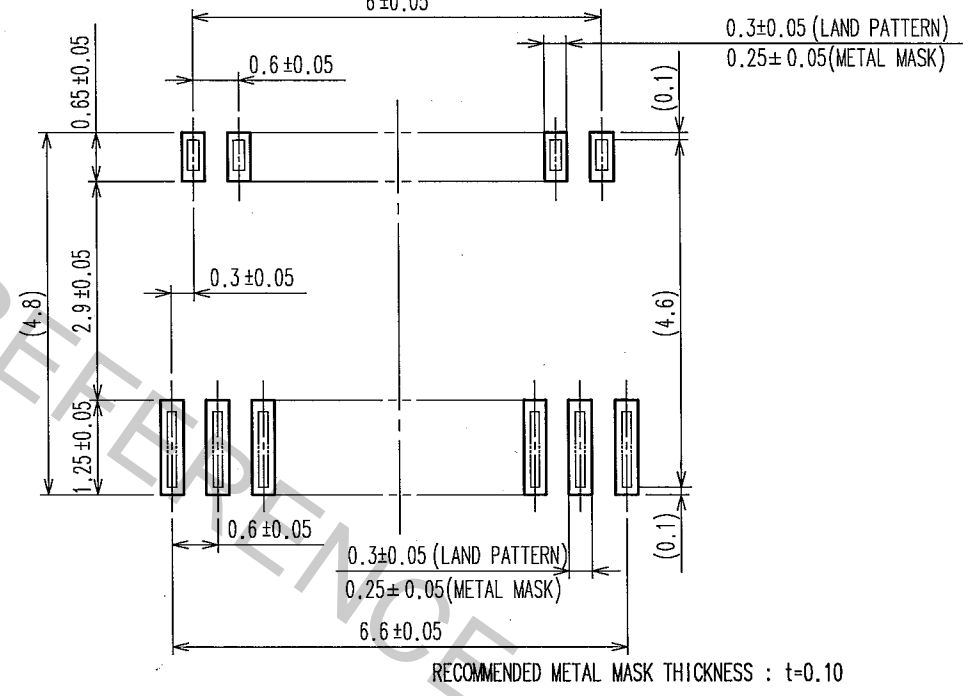

RECOMMENDED METAL MASK THICKNESS : t=0.10

COUNT	DESCRIPTION OF REVISIONS	BY	CHKD	DATE	COUNT	DESCRIPTION OF REVISIONS	BY	CHKD	DATE
△					△				
△					△				
△					△				

3	PHOSPHOR BRONZE	GOLD PLATING (FLASH)			
2	LCP	BLACK	UL94V-0		
1	LCP	BEIGE	UL94V-0	4	PHOSPHOR BRONZE
					GOLD PLATING (FLASH)
NO.	MATERIAL	FINISH, REMARKS	NO.	MATERIAL	FINISH, REMARKS
CODE NO. (OLD)			DRAWN	DESIGNED	CHECKED
			T.OONO	T.MURAI	R. Takayan
			06.07.26	06.07.26	06.07.27
			APPROVED	RELEASED	
DRAWING NO.			PART NO.		
EDC3-153989-01			FH23-23S-0.3SHAW(05)		
SCALE			CODE NO.		
10 : 1			CL586-1325-8-05		
UNITS			1/2		
mm			HRS HIROSE ELECTRIC CO., LTD		

May.1.2017 Copyright 2017 HIROSE ELECTRIC CO., LTD. All Rights Reserved.

COUNT	DESCRIPTION OF REVISIONS	BY	CHKD	DATE	COUNT	DESCRIPTION OF REVISIONS	BY	CHKD	DATE
△					△				
△					△				
△					△				

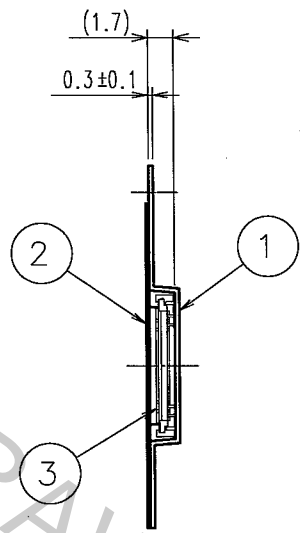
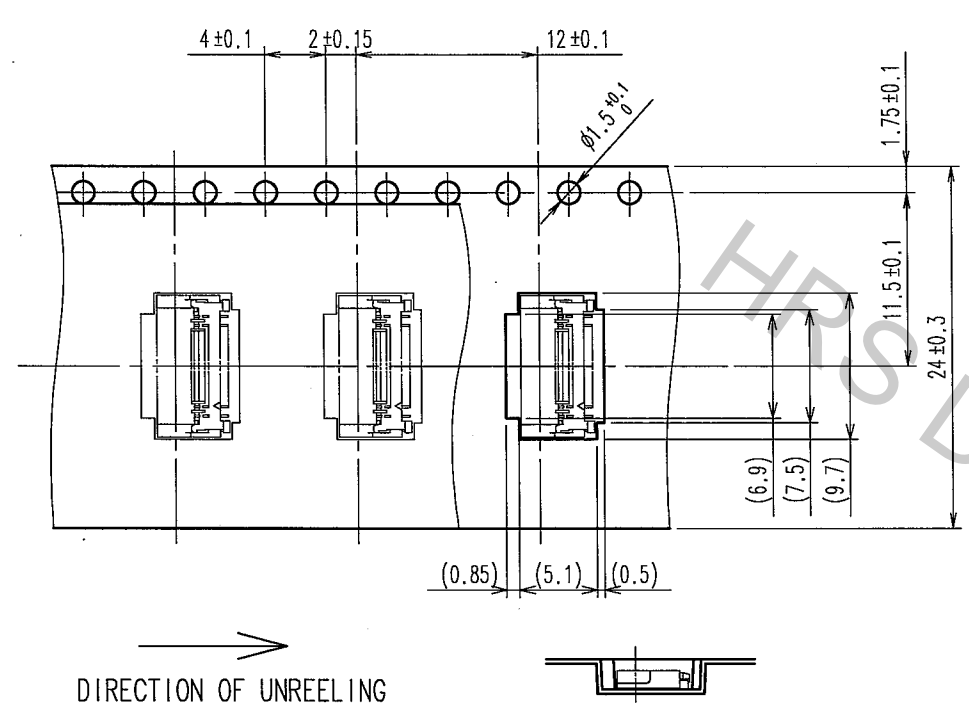

REEL DIMENTION (FREE)

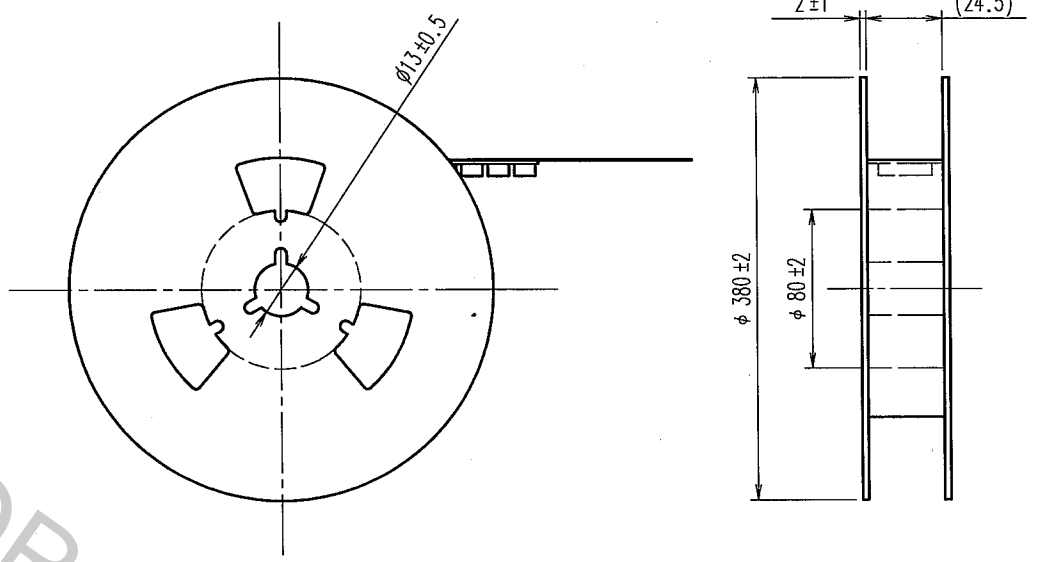

NOTES 1 THE DIMENTIONS IN PARENTHSES ARE FOR REFERENCE.
2 PER REEL : 2500 CONNECTORS.

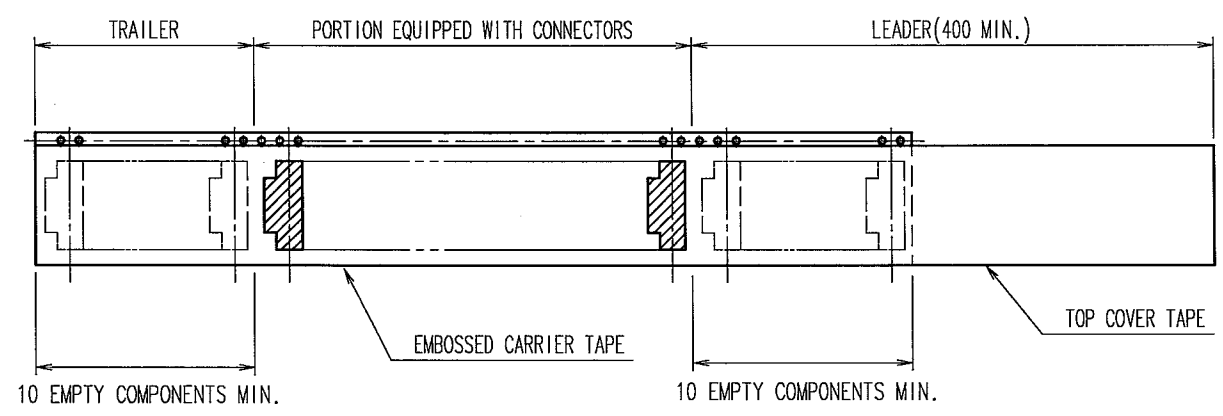

2	POLYESTER		4		
1	POLYSTYRENE		3	(CONNECTOR)	
NO.	MATERIAL	FINISH, REMARKS	NO.	MATERIAL	FINISH, REMARKS
CODE NO. (OLD)			DRAWN	DESIGNED	CHECKED
			T.OONO	T.MURAI	R. Takayama
			06.07.26	06.07.26	06.07.27
					R. Takayama
					06.07.27
DRAWING NO.			PART NO.		
EDC3-153989-01			FH23-23S-0.3SHAW(05)		
SCALE			CODE NO.		
2 : 1			CL586-1325-8-05		
UNITS			2		
mm			HRS HIROSE ELECTRIC CO., LTD		