

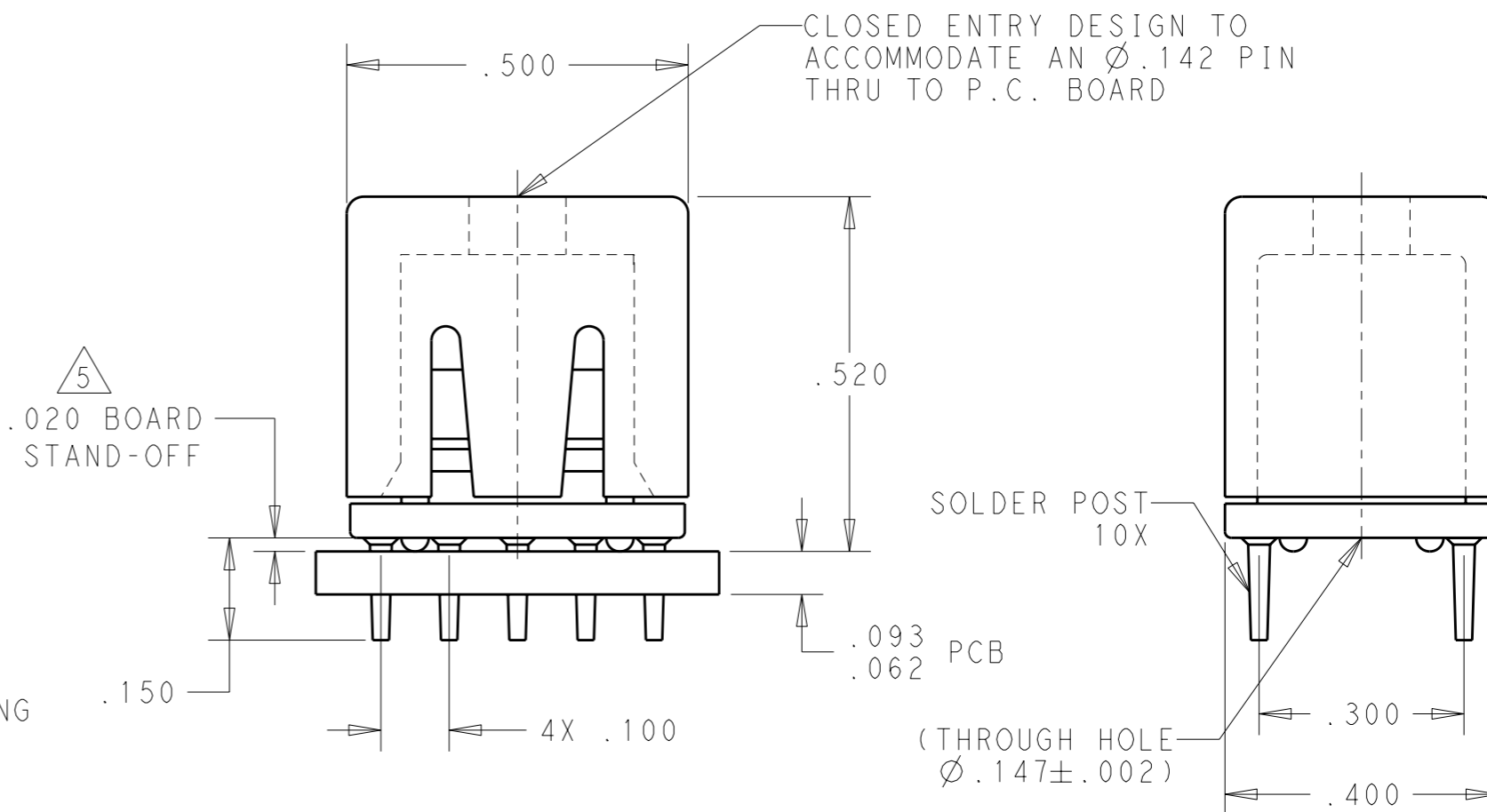

| LOC | DIST | REVISIONS             |           |     |      |  |
|-----|------|-----------------------|-----------|-----|------|--|
| P   | LTR  | DESCRIPTION           | DATE      | DWN | APVD |  |
| GP  | 00   |                       |           |     |      |  |
|     | B    | REV PER ECO-11-007678 | 19MAY2011 | RG  | DO   |  |

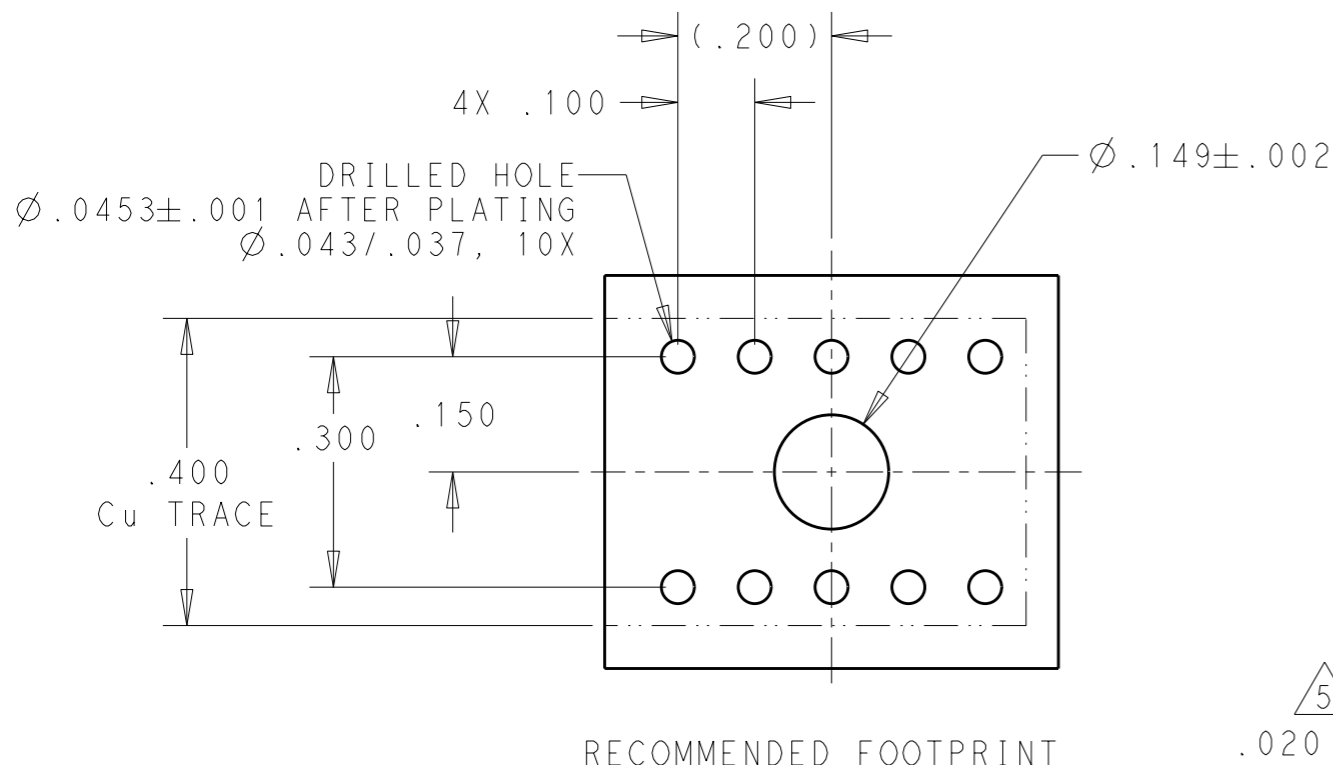

- PART NUMBER CHANGES AND/OR DESIGN CHANGES AFFECTING ITEM INTERCHANGEABILITY REQUIRE PRIOR TE APPROVAL AND AUTHORIZATION BY REVISION TO THIS DRAWING.
- ITEMS PROVIDED TO THIS SPECIFICATION SHALL BE IDENTIFIED ON CONTAINER WITH THE FOLLOWING INFORMATION, PART NUMBER AND DATE CODE OF MANUFACTURE.
- MATERIAL:
  - INSULATOR - POLYESTER, GLASS FILLED, UL94 V-O RATED, COLOR: BLACK
  - MODULE - METAL CASTING
  - CROWN - BeCu
- FINISH:
  - INSERT - SILVER PLATED .000200 MIN THK. OVER NICKEL .000040 MIN THK.
  - CROWN - GOLD PLATED .000030 MIN THK. OVER NICKEL .000040 MIN THK.

5 A FIVE POUND (5lb) FORCES REQUIRED TO CORRECTLY SEAT THE CONNECTOR WITH PLATED THRU HOLES LESS THEN  $\phi .040$ .

6643264-1  
PART NUMBER

|  |       |                                    |   |                         |    |       |    |       |       |       |    |        |     |                |            |  |
|--|-------|------------------------------------|---|-------------------------|----|-------|----|-------|-------|-------|----|--------|-----|----------------|------------|--|
| THIS DRAWING IS A CONTROLLED DOCUMENT.   |       | DWN 19MAY2011<br>LOVATO/GRZYBOWSKI |  TE Connectivity |                         |    |       |    |       |       |       |    |        |     |                |            |  |
| DIMENSIONS: INCHES   |       | CHK -                              |   |                         |    |       |    |       |       |       |    |        |     |                |            |  |
| TOLERANCES UNLESS OTHERWISE SPECIFIED:   |       | APVD 19MAY2011<br>CHAU/ORRIS       | NAME<br>ICCON SOCKET, PERPNDICULAR<br>10 PIN FOOTPRINT<br>SOLDER THRU HOLE                            |                         |    |       |    |       |       |       |    |        |     |                |            |  |
| <table border="0"> <tr><td>0 PLC</td><td>±-</td></tr> <tr><td>1 PLC</td><td>±-</td></tr> <tr><td>2 PLC</td><td>±-</td></tr> <tr><td>3 PLC</td><td>±.020</td></tr> <tr><td>4 PLC</td><td>±-</td></tr> <tr><td>ANGLES</td><td>±.5</td></tr> </table> |       | 0 PLC                              | ±-  | 1 PLC                   | ±- | 2 PLC | ±- | 3 PLC | ±.020 | 4 PLC | ±- | ANGLES | ±.5 | PRODUCT SPEC - | SIZE<br>A3 |  |
| 0 PLC  | ±-    |                                    |   |                         |    |       |    |       |       |       |    |        |     |                |            |  |
| 1 PLC  | ±-    |                                    |   |                         |    |       |    |       |       |       |    |        |     |                |            |  |
| 2 PLC  | ±-    |                                    |   |                         |    |       |    |       |       |       |    |        |     |                |            |  |
| 3 PLC  | ±.020 |                                    |   |                         |    |       |    |       |       |       |    |        |     |                |            |  |
| 4 PLC  | ±-    |                                    |   |                         |    |       |    |       |       |       |    |        |     |                |            |  |
| ANGLES   | ±.5   |                                    |   |                         |    |       |    |       |       |       |    |        |     |                |            |  |
| MATERIAL -   |       | APPLICATION SPEC -                 | CAGE CODE<br>00779  | DRAWING NO<br>C-6643264 |    |       |    |       |       |       |    |        |     |                |            |  |
| FINISH -   |       | WEIGHT -                           | RESTRICTED TO -   |                         |    |       |    |       |       |       |    |        |     |                |            |  |
|  |       | CUSTOMER DRAWING                   | SCALE<br>4:1  | SHEET 1 OF 1 REV B      |    |       |    |       |       |       |    |        |     |                |            |  |