

Contents

NMB Minebea - about ourselves	4
Part numbering system, Pelmec ball bearings	6
Part numbering system, M+I ball bearings	7
NMB ball bearings – dimensions	
Deep groove single row ball bearings (metric)	8
Flanged deep groove single row ball bearings (metric)	14
Deep groove single row ball bearings (imperial)	18
Flanged Deep groove single row ball bearings (imperial)	20
Deep groove single row ball bearings with snap ring	21
Information on applications	
Materials for rings and roller bodies	22
Shields	23
Cages	24
Roller bearing tolerances	25
Corner radii	28
Bearing clearance	29
Lubrication service life - static loadability	30
Pre-stressing/ bearing adjustment	31
Installation tolerances	32
Handling ball bearings	33
Mechanical components	34
Engineering support	36
Sample copy of request form	37

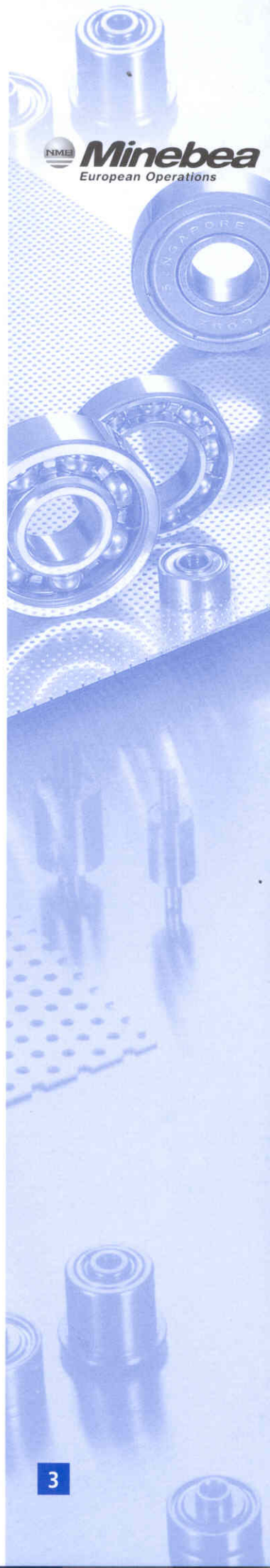



NMB Minebea Ball Bearings

About ourselves

NMB Minebea is **the world's leading manufacturer of miniature ball bearings**. With over 45,000 employees in 70 locations, 200 sales organisations and 40 manufacturing facilities, NMB is now a true multi-national concern.

Founded in Tokyo in 1951, NMB (»Nippon **M**iniature **B**eatings«) started with the development and manufacture of miniature ball bearings. Over the following years, the product range was continuously extended. In nine different countries, the concern now manufactures miniature ball bearings, ventilators and blowers (air-movers), computer keyboards, stepper and geared motors, hi-fi loudspeakers, disk drives and power units and today is **one of the biggest manufacturers of industrial components**.

The manufacturing process known as the **»vertical integration manufacturing system«** has its essential feature in the fact that almost all individual parts for an NMB finished product are manufactured internally.

The manufacturing depth on the one hand, and on the other the development and construction of assembly lines, machines, tools and devices for manufacturing processes together guarantee **an optimum standard of quality for all our products**.

As a leading components manufacturer, today NMB Minebea is active globally - in Japan, Mexico, Brazil, Singapore, Taiwan, Thailand, the USA, China and in Europe.

NMB Minebea Ball Bearings



The NMB Minebea ball bearings group offers technical back-up in Germany, in Langen (Hess) and Villingen. Thus the group is represented in Central Europe and in close proximity to its customers. There are further technology centres in England, Japan, Singapore, Thailand and the USA.

Our technology centres are equipped with all the usual equipment for examination of ball bearings, as well as for product and application analysis.

In addition to the continuing further development of our ball bearing range, high-precision mechanical components (**assemblies**) are developed according to special customer requirements to the production stage and then put into series production.

Manufacturing and inspection processes are being continually developed to improve our product standards even further. Raw materials and lubricant testing, noise-testing and measurement all belong to the day-to-day standards in our production. The level of vertical integration makes it possible for us to manufacture all the components for miniature ball bearings, such as inner and outer rings, the balls, cages, covers and sealing discs in the widest possible variety. As raw material, we use a selection of ball bearing and corrosion-resistant steel. Similarly, various types of radial bearings and lubricants (grease and oils) are available for both normal and exceptional service and applications. Manufacturing is carried out either in accordance with JIS (ISO) or AFBMA standards (ABEC).

Today, NMB provides a **wide range of services**. These extend from individual customer advice to planning and design specifications of ball bearings. Similarly, we offer services accompanying projects, ball bearing analysis and functional and endurance-testing.

The high level of quality of our products is achieved through continuous and permanent quality checking. NMB Minebea is ISO 9000 certificated, and our production facilities are ISO 9000, QS 9000 and ISO 14001 certificated.

CFC- and trichloroethylene-free manufacture was introduced in our factories in the early 1990s. In 1993, 1995 and 1997 NMB-Minebea was awarded the accolade **»Best of the Best«** by the American Environmental Protection Agency on this account.

We count amongst our customers renowned firms in the automotive industry, ventilator, blower, measuring device, domestic equipment and electric motor manufacturers.

We are therefore not merely a reliable supplier, but also partners on both a local and a global scale.

PELMEC* Parts numbering system

*PELMEC: Precision **E**lectro **M**Echanic Bearings

This numbering system is valid for the following part numbers:

607, 608, 609, 626, 627, 629, 635, 6000, 6001

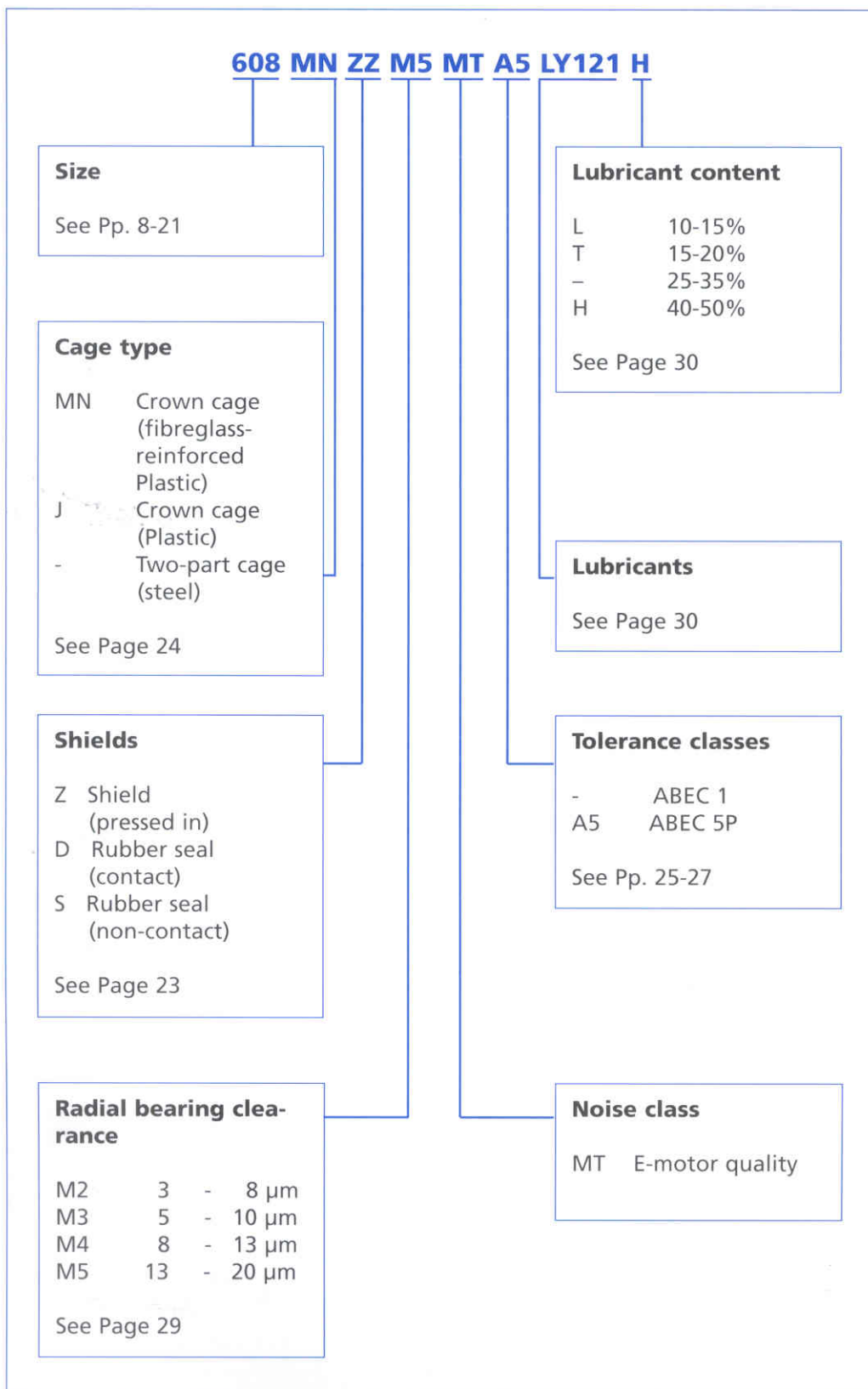

M+I*-Parts numbering system

*M+I: Miniature + Instrument Bearings

DD R 2280 HH MT R A1 P25 LY121 H

Material

- Roller bearing steel
- DD Stainless steel

See Page 22

Series

- R: R-series, metric (D/d large)
- RF: R-series, flanged, metric
- RI: R-series, imperial
- RI: R-series, imperial, flanged
- L: L-series, metric (D/d small)
- LI: L-series, imperial
- LF: L-series, metric, flanged
- A: A-series (D/d very small)

See Pp. 8-21

Sizes

See Pages 8-21

- H Shield (pressed in)
- Z Shield (fitted in with securing ring)
- D Rubber seal (contact)
- S Rubber seal (non-contact)
- L PTFE disc

See Page 23

Noise class

- Sound-tested
- MT E-motor quality

Lubricant content

- L 10-15 %
- T 15-20 %
- 25-35 %
- H 40-50 %

See Page 30

Lubricants

See Page 30

Radial bearing clearance

- M2 3 - 8 μ m
- M3 5 - 10 μ m
- M4 5 - 13 μ m
- M5 13 - 20 μ m

See Page 29

Tolerance classes

- A1 ABEC 1
- A5 ABEC 5P

See Pp. 25-27

Cage type

- MN Crown cage (Plastic, glass-fibre reinforced)
- J Crown cage (Plastic)
- H Crown cage (Steel)
- R Two-part cage (steel)

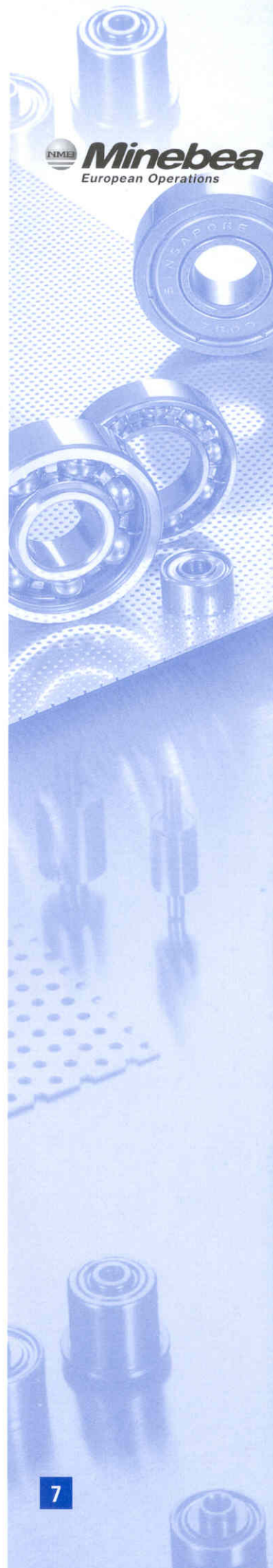

See Page 24



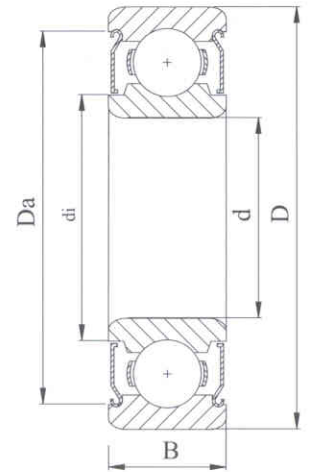

Deep groove single row ball bearings (metric)





bore Ø d (mm)	outer Ø D (mm)	width B (mm)	JIS/ISO	NMB designation	NMB designation	Da (mm)	di (mm)	ball Ø (mm)	no. of ball bear.	Dyn. C (N)	Stat. C ₀ (N)
1	3	1	618/1	L-310		2,41	1,60	0,5000	7	80	23
1	3	1,5	638/1	L-310W51		2,41	1,60	0,5000	7	80	23
1	4	1,6	619/1	R-410		3,16	2,05	0,7938	6	158	44
1	4	2	-		R-410ZZ	3,42	2,15	0,6000	7	113	34
1,2	4	1,2	-	R-412		3,16	2,05	0,7938	6	158	44
1,5	4	1,2	618/1,5	L-415		3,25	2,26	0,6350	7	125	38
1,5	4	2	638/1,5		L-415X5ZZ	3,42	2,15	0,6000	7	113	34
1,5	4	2	638/1,5		L-415ZZ	3,49	2,26	0,6350	7	125	38
1,5	4	2,5	-		L-415ZZW52	3,49	2,26	0,6350	7	125	38
1,5	5	2	619/1,5	R-515		3,73	2,60	0,7938	7	184	57
1,5	5	2,6	639/1,5		R-515ZZ	4,03	2,60	0,7938	7	184	57
1,5	6	2,5	610/1,5	R-615		4,73	2,90	1,1906	6	324	97
2	5	1,5	618/2	L-520		4,00	2,90	0,7938	7	187	59
2	5	2	-	L-520W02		4,00	2,90	0,7938	7	187	59
2	5	2,3	638/2		L-520ZZ	4,28	2,90	0,7938	7	187	59
2	5	2,5	-		L-520ZZW52	4,28	2,90	0,7938	7	187	59
2	5	2,5	-	L-520W52		4,00	2,90	0,7938	7	187	59
2	6	2,3	619/2	R-620		4,78	3,16	1,0000	7	279	89
2	6	2,3	619/2		R-620ZZY32	5,23	3,16	1,0000	7	279	89

bore Ø d (mm)	outer Ø D (mm)	width B (mm)	JIS/ISO	NMB designation 	NMB designation 	Da (mm)	di (mm)	ball Ø (mm)	no. of ball bear.	Dyn. C (N)	Stat. C ₀ (N)
2	6	2,5	-	R-620W52		5,23	3,10	1,1906	6	330	99
2	6	2,5	-		R-620ZZY52	5,23	3,10	1,1906	6	330	99
2	6	3	639/2		R-620ZZ	5,23	3,10	1,1906	6	330	99
2	6	3	639/2	R-620W03		4,93	3,10	1,1906	6	330	99
2	7	2,5	-	R-720Y52		5,52	3,80	1,1906	7	380	126
2	7	2,8	610/2	R-720		5,52	3,80	1,1906	7	380	126
2	7	3	-		R-720ZZY03	5,93	3,80	1,1906	7	380	126
2	7	3,5	630/2		R-720ZZ	5,93	3,80	1,1906	7	380	126
2,5	6	1,8	618/2,5	L-625		4,93	3,80	0,7938	8	206	73
2,5	6	2,6	638/2,5		L-625ZZ	5,23	3,80	0,7938	8	206	73
2,5	7	2,5	619/2,5	R-725		5,52	3,80	1,1906	7	380	126
2,5	7	3	-		R-725ZZY03	5,93	3,80	1,1906	7	380	126
2,5	7	3,5	639/2,5		R-725ZZ	5,93	3,80	1,1906	7	383	126
2,5	8	2,8	610/2,5	R-825		6,53	4,10	1,5875	6	553	176
2,5	8	2,8	610/2,5		R-825ZZY82	6,89	4,77	1,1906	8	426	156
2,5	8	4	630/2,5		R-825ZZ	7,19	4,10	1,5875	6	553	176
3	6	2	617/3	L-630		4,93	3,80	0,7938	8	206	73
3	6	2,5	-		L-630ZZ	5,23	3,80	0,7938	8	206	73
3	7	2	618/3	L-730		5,83	4,10	1,1906	7	384	129
3	7	3	638/3		L-730ZZ	6,13	4,10	1,1906	7	384	129
3	7	3	638/3	L-730W03		5,83	4,10	1,1906	7	384	129
3	8	2,5	-	R-830Y52		6,53	4,10	1,5875	6	553	176
3	8	3	619/3	R-830		6,53	4,10	1,5875	6	553	176
3	8	3	619/3		R-830ZZY03	6,89	4,77	1,1906	8	426	156
3	8	4	639/3		R-830ZZ	7,20	4,10	1,5875	6	553	176
3	9	2,5	-	R-930Y52		7,23	4,80	1,5875	7	634	219
3	9	3	610/3	R-930		7,23	4,80	1,5875	7	634	219
3	9	4	-		R-930ZZY04	7,64	4,80	1,5875	7	634	219
3	9	5	630/3		R-930ZZ	7,64	4,80	1,5875	7	634	219
3	10	4	623	R-1030		8,20	5,08	1,5875	7	641	226
3	10	4	623		R-1030ZZ	8,20	5,08	1,5875	7	641	226
4	7	2	617/4	L-740		5,93	4,80	0,7938	11	252	106



Deep groove single row ball bearings (metric)

bore Ø d (mm)	outer Ø D (mm)	width B (mm)	JIS/ISO	NMB designation 	NMB designation 	Da (mm)	di (mm)	ball Ø (mm)	no. of ball bear.	Dyn. C (N)	Stat. C ₀ (N)
4	7	2,5	-		L-740ZZ	6,33	4,80	0,7938	11	252	106
4	8	2	-	L-840		6,93	5,20	1,1906	7	384	140
4	8	3	-	L-840W03		7,24	5,20	1,1906	7	384	140
4	8	3	-		L-840ZZ	7,24	5,20	1,1906	7	384	140
4	9	2,5	618/4	L-940		7,48	5,20	1,5875	7	641	226
4	9	3,5	628/4		L-940ZZY53	7,31	5,62	1,1906	7	391	142
4	9	4	638/4		L-940ZZ	7,93	5,20	1,5875	7	641	226
4	10	3	-	L-1040X2		7,96	5,80	1,5875	8	708	266
4	10	4	-		L-1040X2ZZ	8,50	5,46	1,5875	8	708	265
4	11	4	619/4	R-1140		9,53	6,40	1,5875	8	708	276
4	11	4	619/4		R-1140ZZ	9,54	6,40	1,5875	8	708	276
4	12	4	610/4	R-1240		9,99	5,62	2,0000	7	959	347
4	12	4	610/4		R-1240ZZ	9,99	5,62	2,0000	7	959	347
4	13	5	624	R-1340		11,20	5,97	2,3813	7	1306	487
4	13	5	624		R-1340HH	11,20	5,97	2,3813	7	1306	487
4	16	5	634	R-1640		13,41	7,80	2,7782	7	1735	671
4	16	5	634		R-1640HH	13,41	7,80	2,7782	7	1735	671
5	8	2	617/5	L-850		6,95	5,80	0,7938	13	274	130
5	8	2,5	-		L-850ZZ	7,26	5,80	0,7938	13	274	130
5	9	2,5	-	L-950		7,73	6,00	1,1906	10	495	207
5	9	3	-		L-950ZZ	8,04	6,00	1,1906	10	495	207
5	10	3	-	L-1050		8,63	6,40	1,5875	8	714	276
5	10	4	-		L-1050ZZ	8,94	6,40	1,5875	8	714	276
5	11	3	618/5	L-1150		8,63	6,40	1,5875	8	714	276
5	11	4	628/5		L-1150ZZY04	9,54	6,95	1,5875	7	714	276
5	11	5	638/5		L-1150ZZ	9,54	6,40	1,5875	8	714	276
5	13	4	619/5	R-1350		11,14	6,66	2,0000	8	1074	422
5	13	4	619/5		R-1350ZZ	11,14	6,66	2,0000	8	1074	422
5	13	5	-	R-1350W05		11,04	7,00	2,3813	7	1306	487
5	13	5	-		R-1350ZZW05	11,04	7,00	2,3813	7	1306	487
5	14	5	610/5	R-1450		12,14	6,88	2,3813	7	1329	508
5	14	5	610/5		R-1450ZZ	12,14	6,88	2,3813	7	1329	508

bore Ø d (mm)	outer Ø D (mm)	width B (mm)	JIS/ISO	NMB designation 	NMB designation 	Da (mm)	di (mm)	ball Ø (mm)	no. of ball bear.	Dyn. C (N)	Stat. C ₀ (N)
------------------------	-------------------------	--------------------	---------	---	---	------------	------------	-------------------	----------------------------	------------------	--------------------------------

5	16	5	625	R-1650		13,41	7,80	2,7782	7	1735	671
5	16	5	625		R-1650HH	13,41	7,80	2,7782	7	1735	671
5	19	6	635	635		16,60	10,60	3,5000	7	2614	1059
5	19	6	635		635ZZ	16,60	9,20	3,5000	7	2614	1059
5	19	6	635	R-1950		16,26	8,67	3,9689	6	2815	1069
5	19	6	635		R-1950ZZ	16,26	8,67	3,9689	6	2815	1069
6	10	2,5	617/6	L-1060		8,73	6,95	1,1906	9	457	194
6	10	3	-		L-1060ZZ	9,04	6,95	1,1906	9	457	194
6	12	3	-	L-1260		9,94	7,70	1,5875	10	834	363
6	12	4	-		L-1260ZZ	10,48	7,70	1,5875	10	834	363
6	13	3,5	618/6	L-1360		10,98	8,00	2,0000	8	1083	438
6	13	4,5	-		L-1360ZZY54	11,44	7,33	2,0000	8	1083	438
6	13	5	628/6		L-1360ZZ	11,44	7,33	2,0000	8	1083	438
6	15	5	619/6	R-1560X2		13,20	7,80	2,7782	7	1735	671
6	15	5	619/6		R-1560X2ZZ	13,20	7,80	2,7782	7	1735	671
6	16	5	-		R-1660HH	13,41	8,60	2,7782	7	1735	671
6	17	6	610/6	R-1760X2		14,70	8,22	3,5000	6	2265	839
6	17	6	610/6		R-1760X2ZZ	14,70	8,22	3,5000	6	2265	839
6	19	6	626	626		16,68	9,20	3,5000	7	2614	1059
6	19	6	626		626ZZ	16,68	9,20	3,5000	7	2614	1059
6	19	6	626	R-1960		16,26	8,67	3,9689	6	2815	1069
6	19	6	626		R-1960ZZ	16,26	8,67	3,9689	6	2815	1069
6	19	6	626		626ZZSD02	16,68	10,60	3,5000	7	2614	1053
7	11	2,5	617/7	L-1170		9,83	8,10	1,1906	9	449	199
7	11	3	-		L-1170ZZ	10,14	8,10	1,1906	9	449	199
7	13	3	-	L-1370		11,13	8,90	1,5875	11	883	414
7	13	4	-		L-1370ZZ	11,54	8,43	1,5875	11	883	414
7	14	3,5	618/7	L-1470		12,03	9,00	2,0000	9	1175	511
7	14	5	628/7		L-1470ZZ	12,45	9,00	2,0000	9	1175	511
7	17	5	619/7		R-1770HH	14,20	9,68	2,3813	9	1606	712
7	19	6	607	R-1970		16,24	9,55	3,1750	7	2246	912
7	19	6	607		R-1970ZZ	16,24	9,55	3,1750	7	2246	912

Deep groove single row ball bearings (metric)

bore Ø d (mm)	outer Ø D (mm)	width B (mm)	JIS/ISO	NMB designation 	NMB designation 	Da (mm)	di (mm)	ball Ø (mm)	no. of ball bear.	Dyn. C (N)	Stat. C ₀ (N)
7	19	6	607	607		16,68	9,20	3,5000	7	2614	1059
7	19	6	607		607ZZ	16,68	9,20	3,5000	7	2614	1059
7	19	6	607		607ZZSD02	16,68	10,60	3,5000	7	2614	1059
7	22	7	627	627		19,02	10,80	3,9688	7	3297	1368
7	22	7	627		627ZZ	19,02	10,80	3,9688	7	3297	1368
7	22	7	627	R-2270		19,08	10,80	3,9688	7	3297	1368
7	22	7	627		R-2270ZZ	18,89	10,80	3,9688	7	3297	1368
7	22	7	627		627ZZSD02	19,10	12,40	3,9688	7	3297	1368
8	12	2,5	617/8	L-1280		10,93	9,10	1,1906	11	510	255
8	12	3,5	637/8		L-1280ZZ	11,24	9,10	1,1906	11	510	255
8	14	3,5	-	L-1480		12,13	9,90	1,5875	10	819	386
8	14	4	-		L-1480ZZ	12,55	9,90	1,5875	10	819	386
8	16	4	618/8	L-1680		13,63	10,40	2,3813	9	1606	712
8	16	5	628/8		L-1680HH	14,20	9,68	2,3813	9	1606	712
8	16	5	628/8		L-1680X2HH	14,18	10,30	2,3813	9	1606	712
8	16	6	638/8		L-1680HHW06	14,20	9,68	2,3813	9	1606	712
8	19	6	619/8	R-1980		16,68	10,60	3,1750	8	2463	1059
8	19	6	619/8		R-1980HH	16,68	10,60	3,1750	8	2463	1059
8	19	8	-		R-1980HHW08	16,68	10,60	3,1750	8	2463	1059
8	22	7	608	608		19,10	10,80	3,9688	7	3297	1368
8	22	7	608		608ZZ	19,10	10,80	3,9688	7	3297	1368
8	22	7	608	R-2280		19,07	10,80	3,9688	7	3297	1368
8	22	7	608		R-2280ZZ	18,89	10,76	3,9688	7	3297	1368
8	22	7	608		608ZZSD02	19,10	12,40	3,9688	7	3297	1368
8	24	8	628		R-2480HH	19,10	12,00	3,9688	7	3297	1368
9	17	4	618/9	L-1790		14,84	11,20	2,3813	10	1724	813
9	17	5	628/9		L-1790ZZ	15,34	11,20	2,3813	10	1724	813
9	20	6	619/9	L-2090		17,74	12,32	2,7782	9	2123	985
9	20	6	619/9		L-2090ZZ	17,44	12,32	2,7782	9	2123	985
9	24	7	609	609		19,10	12,40	3,9688	7	3297	1368
9	24	7	609		609ZZ	19,00	12,40	3,9688	7	3297	1368
9	26	8	629	629		22,80	12,88	4,7625	7	4581	1972



bore Ø d (mm)	outer Ø D (mm)	width B (mm)	JIS/ISO	NMB designation 	NMB designation 	Da (mm)	di (mm)	ball Ø (mm)	no. of ball bear.	Dyn. C (N)	Stat. C ₀ (N)
------------------------	-------------------------	--------------------	---------	---	---	------------	------------	-------------------	----------------------------	------------------	--------------------------------

9	26	8	629		629ZZ	22,80	12,88	4,7625	7	4581	1972
9	26	8	629	R-2690		21,25	13,80	4,7625	7	4578	1970
9	26	8	629		R-2690ZZ	22,65	13,80	4,7625	7	4578	1970
10	15	3	61700	A-1510		13,60	11,25	1,5875	11	857	435
10	15	4	-		A-1510ZZ	14,00	11,25	1,5875	11	857	435
10	19	5	61800	L-1910		17,74	12,32	2,7782	9	2123	985
10	19	5	61800		L-1910ZZY05	17,40	12,32	2,7782	9	2123	985
10	19	7	63800		L-1910ZZ	17,44	12,32	2,7782	9	2123	985
10	19	7	63800	L-1910W07		17,44	12,32	2,7782	9	2123	985
10	20	5	-		L-2010ZZY05	17,44	12,32	2,7782	9	2123	985
10	20	6	-		L-2010ZZ	17,44	12,32	2,7782	9	2123	985
10	22	6	61900		R-2210X3HHS21	19,40	13,40	3,1750	9	2697	1273
10	26	8	6000		6000ZZ	22,80	13,75	4,7625	7	4578	1970
10	26	8	6000	6000		22,80	13,75	4,7625	7	4578	1970
10	26	8	6000	R-2610		21,25	14,80	4,7625	7	4578	1970
10	26	8	6000		R-2610ZZ	22,42	13,76	4,7625	7	4578	1970
12	21	5	61801		L-2112HH	19,60	14,74	2,3813	12	1917	1042
12	24	6	61901		R-2412X3ZZ	21,69	15,35	3,5718	8	3082	1433
12	28	8	6001	6001		24,50	16,65	4,76	8	5100	2360
12	28	8	6001		6001ZZ	24,50	16,65	4,76	8	5100	2360
15	20	3,5	-	A-2015		18,43	16,40	1,5875	14	944	582
15	21	3,5	-	A-2115		18,93	16,80	1,5875	14	938	581
15	24	5	61802	L-2415		22,00	17,70	2,3813	14	2076	1258
15	24	5	61802		L-2415ZZ	22,00	17,70	2,3813	14	2076	1258
16	22	4	-	A-2216		19,90	17,80	1,5875	15	969	619
16	22	4	-		A-2216ZZ	20,72	17,80	1,5875	15	969	619
18	24	4	-	A-2418		21,90	19,75	1,5875	16	988	654
20	25	4	-	A-2520		23,40	21,35	1,5875	17	1012	691
20	25	4	-		A-2520ZZ	23,80	21,35	1,5875	17	1012	691

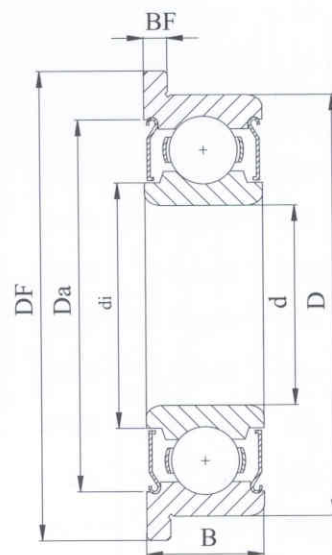
Flanged deep groove single row ball bearings (metric)

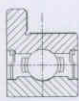





bore Ø d (mm)	outer Ø D (mm)	width B (mm)	JIS/ISO	NMB-des. 	NMB-designation 	flange Ø DF (mm)	flange width BF (mm)	Da (mm)	di (mm)	ball Ø (mm)	no. of ball bear.	Dyn. C (N)	Stat. C ₀ (N)
1	3	1	618/1	LF-310		3,80	0,30	2,41	1,60	0,5000	7	80	23
1,5	4	1,2	618/1,5	LF-415		5,00	0,40	3,24	2,26	0,6350	7	125	38
1,5	5	2,6	639/1,5	RF-515		6,50	0,80	4,03	2,00	0,7938	7	186	59
1,5	5	2,6	639/1,5		RF-515ZZ	6,50	0,80	4,03	2,60	0,7938	7	186	59
1,5	6	3			RF-615ZZ	7,50	0,80	5,00	2,90	1,1906	6	334	98
2	5	1,5	618/2	LF-520		6,10	0,50	4,01	2,90	0,7938	7	187	59
2	5	2,3	638/2		LF-520ZZ	6,10	0,60	4,28	2,90	0,7938	7	186	59
2	6	2,3	619/2	RF-620		7,50	0,60	4,78	3,16	1,0000	7	279	89
2	6	2,5	-		RF-620ZZY52	7,20	0,60	5,23	3,10	1,1906	6	330	99
2	6	3	639/2		RF-620ZZ	7,50	0,80	5,23	3,10	1,1906	6	334	108
2	7	3	-		RF-720ZZY03	8,20	0,60	5,93	3,80	1,1906	7	380	126
2	7	3,5	630/2		RF-720ZZ	8,50	0,90	5,93	3,80	1,1906	7	383	128
2,5	6	1,5		LF-625Y51		7,10	0,50	4,93	3,80	0,7938	8	206	73
2,5	6	1,8	618/2,5	LF-625		7,10	0,50	4,93	3,80	0,7938	8	206	73
2,5	6	2,6	638/2,5		LF-625ZZ	7,10	0,80	5,23	3,80	0,7938	8	206	78

bore Ø d (mm)	outer Ø D (mm)	width B (mm)	JIS/ISO	NMB-des. 	NMB-designation 	flange Ø DF (mm)	flange width BF (mm)	Da (mm)	di (mm)	ball Ø (mm)	no. of ball bear.	Dyn. C (N)	Stat. C ₀ (N)
------------------------	-------------------------	--------------------	---------	---	--	---------------------------	-------------------------------	------------	------------	-------------------	----------------------------	------------------	--------------------------------

2,5	7	3	-		RF-725ZZY03	8,20	0,60	5,93	3,80	1,1906	7	380	126
2,5	7	3,5	639/2,5		RF-725ZZ	8,50	0,90	5,93	3,80	1,1906	7	383	128
2,5	8	2,8	610/2,5	RF-825		9,50	0,70	6,53	4,10	1,5875	6	553	176
2,5	8	4	630/2,5		RF-825ZZ	9,50	0,90	7,20	4,10	1/16	6	559	177
3	6	2	617/3	LF-630		7,20	0,60	4,93	3,80	0,7938	8	206	73
3	6	2,5	-		LF-630ZZ	7,20	0,60	5,23	3,80	0,7938	8	206	78
3	7	2	618/3	LF-730		8,10	0,50	5,83	4,10	1,1906	7	384	129
3	7	3	638/3		LF-730ZZ	8,10	0,80	6,14	4,10	1,1906	7	392	137
3	8	2,5	-	RF-830Y52		9,20	0,60	6,53	4,10	1,5875	6	553	176
3	8	3	619/3	RF-830		9,50	0,70	6,53	4,10	1,5875	6	553	176
3	8	4	639/3		RF-830ZZ	9,50	0,90	7,19	4,10	1,5875	6	553	176
3	9	4	-		RF-930ZZY04	10,60	0,80	7,64	4,80	1,5875	7	638	226
3	9	5	630/3		RF-930ZZ	10,50	1,00	7,64	4,80	1/16	7	638	226
3	10	4	623		RF-1030ZZ	11,50	1,00	8,20	5,08	1,5875	7	647	226
4	7	2	617/4	LF-740		8,20	0,60	5,93	4,80	0,7938	11	252	106
4	7	2,5	-		LF-740ZZ	8,20	0,60	6,33	4,80	0,7938	11	252	106
4	8	2	-	LF-840		9,20	0,60	6,93	5,20	1,1906	7	391	140
4	8	3	-		LF-840ZZ	9,20	0,60	7,24	5,20	1,1906	7	391	140
4	9	2,5	618/4	LF-940		10,30	0,60	7,48	5,20	1,5875	7	641	226
4	9	4	638/4		LF-940ZZ	10,30	1,00	7,93	5,20	1,5875	7	647	226
4	10	3	-	LF-1040X2		11,20	0,60	7,96	5,80	1,5875	8	708	266
4	10	4	-		LF-1040X2ZZ	11,60	0,80	8,50	5,46	1,5875	8	708	266
4	11	4	619/4	RFW-1140		12,60	0,80	8,60	6,40	1,5875	8	714	276
4	11	4	619/4		RF-1140ZZ	12,50	1,00	9,54	6,40	1,5875	8	714	276
4	12	4	-	RF-1240		13,50	1,00	9,99	5,62	2,0000	7	959	347
4	12	4	610/4		RF-1240ZZ	13,50	1,00	9,99	5,62	2,0000	7	959	347
4	13	5	624		RF-1340ZZ	15,00	1,00	11,04	7,00	2,3813	7	1306	487
4	16	5	634		RF-1640ZZ	18,00	1,00	13,20	7,80	2,3813	7	1735	671
5	8	2	617/5	LF-850		9,20	0,60	6,95	5,80	0,7938	13	274	130
5	8	2,5	-		LF-850ZZ	9,20	0,60	7,26	5,80	0,7938	13	274	130
5	9	2,5	-	LF-950		10,20	0,60	7,73	6,00	1,1906	10	495	207
5	9	3	-		LF-950ZZ	10,20	0,60	8,04	6,00	1,1906	10	495	207

Flanged deep groove single row ball bearings (metric)



bore Ø d (mm)	outer Ø D (mm)	width B (mm)	JIS/ISO	NMB-des. 	NMB-designation 	flange Ø DF (mm)	flange width BF (mm)	Da (mm)	di (mm)	ball Ø (mm)	no. of ball bear.	Dyn. C (N)	Stat. C ₀ (N)
5	10	3	-	LF-1050		11,20	0,60	8,63	6,40	1,5875	8	714	276
5	10	4	-		LF-1050ZZ	11,60	0,80	8,94	6,40	1,5875	8	714	276
5	11	3	618/5	LF-1150		12,50	0,80	8,63	6,40	1,5875	8	714	276
5	11	4	628/5		LF-1150ZZY04	12,60	0,80	9,54	6,40	1,5875	8	714	276
5	11	5	638/5		LF-1150ZZ	12,50	1,00	9,54	6,40	1,5875	8	714	276
5	13	4	619/5	RF-1350		15,00	1,00	11,14	6,66	2,0000	8	1074	422
5	13	4	619/5		RF-1350ZZ	15,00	1,00	11,14	6,66	2,0000	8	1074	422
5	13	5	-		RF-1350ZZW05	15,00	1,00	11,04	7,00	2,3813	7	1306	487
5	14	5	610/5	RF-1450		16,00	1,00	12,14	6,88	2,3813	7	1329	508
5	14	5	610/5		RF-1450ZZ	16,00	1,00	12,14	6,88	2,3813	7	1334	510
5	16	5	625		RF-1650HH	18,00	1,00	13,41	7,80	2,7782	7	1736	677
5	19	6	635	RF-1950		22,00	1,50	15,60	8,67	3,9688	6	2805	1060
5	19	6	635		RF-1950ZZ	22,00	1,50	16,26	8,67	3,9688	6	2805	1060
6	10	2,5	617/6	LF-1060		11,20	0,60	8,73	6,95	1,1906	9	457	194
6	10	3	-		LF-1060ZZ	11,20	0,60	9,04	6,95	1,1906	9	457	194
6	12	3	-	LF-1260		13,20	0,60	9,94	7,70	1,5875	10	831	363
6	12	4	-		LF-1260ZZ	13,60	0,80	10,48	7,70	1,5875	10	831	363
6	13	3,5	618/6	LF-1360		15,00	1,00	10,98	8,00	2,0000	8	1083	438
6	13	4,5	-		LF-1360ZZY54	15,00	1,00	11,44	7,33	2,0000	8	1083	438
6	13	5	628/6		LF-1360ZZ	15,00	1,10	11,44	7,33	2,0000	8	1083	438
6	15	5	619/6	RF-1560		17,00	1,20	13,20	7,80	2,7782	7	1735	671
6	15	5	619/6		RF-1560ZZ	17,00	1,20	13,20	7,80	2,7782	7	1735	671
6	17	6	610/6		RF-1760X2ZZ	19,00	1,20	14,70	8,22	3,5000	6	2265	839
6	19	6	626		RF-1960ZZ	22,00	1,50	16,26	8,67	3,9688	6	2805	1060
7	11	2,5	617/7	LF-1170		12,20	0,60	9,83	8,10	1,1906	9	449	199
7	11	3	-		LF-1170ZZ	12,20	0,60	10,14	8,10	1,1906	9	449	199
7	13	3	-	LF-1370		14,20	0,60	11,13	8,90	1,5875	11	880	414
7	13	4	-		LF-1370ZZ	14,60	0,80	11,54	8,43	1,5875	11	880	414
7	14	3,5	618/7	LF-1470		16,00	1,00	12,03	9,00	2,0000	9	1175	511
7	14	5	628/7		LF-1470ZZ	16,00	1,10	12,45	9,00	2,0000	9	1175	511
7	19	6	607		RF-1970ZZ	22,00	1,50	16,24	9,55	3,1750	7	2240	912
7	22	7	627		RF-2270HH	25,00	1,50	19,07	10,80	3,9688	7	3297	1368

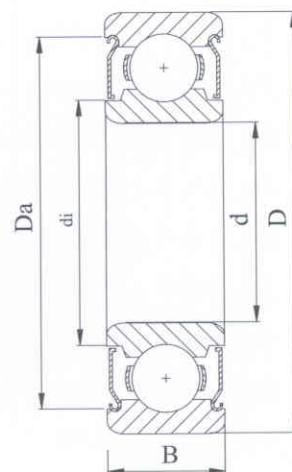
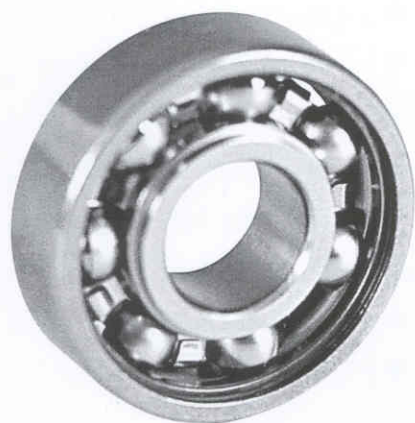

bore Ø d (mm)	outer Ø D (mm)	width B (mm)	JIS/ISO	NMB-des. 	NMB-designation 	flange Ø DF (mm)	flange width BF (mm)	Da (mm)	di (mm)	ball Ø (mm)	no. of ball bear.	Dyn. C (N)	Stat. C ₀ (N)
------------------------	-------------------------	--------------------	---------	---	--	---------------------------	-------------------------------	------------	------------	-------------------	----------------------------	------------------	--------------------------------

8	12	2,5	617/8	LF-1280		13,20	0,60	10,93	9,10	1,1906	11	506	249
8	12	3,5	637/8		LF-1280ZZ	13,60	0,80	11,24	9,10	1,1906	11	506	249
8	14	3,5	-	LF-1480		15,60	0,80	12,13	9,90	1,5875	10	819	386
8	14	4	-		LF-1480X3ZZ	15,60	0,80	11,77	9,20	1,5875	11	878	419
8	16	4	618/8	LF-1680		18,00	1,00	13,40	10,30	2,3813	9	1606	712
8	16	4	618/8	LFW-1680		17,60	0,80	13,40	10,30	2,3813	9	1606	712
8	16	5	628/8		LF-1680HH	18,00	1,10	14,20	9,68	2,3813	9	1606	712
8	16	6	638/8		LF-1680ZZW06	18,00	1,10	14,04	9,73	2,3813	9	1607	716
8	19	6	619/8	RF-1980		22,00	1,50	16,24	9,55	3,1750	7	2240	912
8	19	6	619/8		RF-1980ZZ	22,00	1,50	16,24	9,55	3,1750	7	2240	912
8	22	7	608	RF-2280		25,00	1,50	18,89	10,76	3,9688	7	3297	1368
8	22	7	608		RF-2280HH	25,00	1,50	19,07	10,80	3,9688	7	3297	1368
9	17	4	618/9	LF-1790		19,00	1,00	14,81	11,20	2,3813	10	1724	813
9	17	5	628/9		LF-1790ZZ	19,00	1,10	15,34	11,20	2,3813	10	1724	813
10	15	4	-		AF-1510ZZ	16,50	0,80	14,04	11,25	1,5875	11	857	435
10	19	5	61800	LF-1910		22,00	1,50	16,68	12,32	2,7782	9	2123	985
10	19	5	61800		LF-1910ZZY05	22,00	1,50	17,44	12,32	2,7782	9	2123	985
10	19	7	63800		LF-1910ZZ	22,00	1,50	17,44	12,32	2,7782	9	2123	985
10	20	6	-		RF-2210X2HH	25,00	1,50	19,08	12,40	3,1750	9	2697	1273

Deep groove single row ball bearings (imperial)





bore Ø d (mm)	outer Ø D (mm)	width B (mm)	JIS/ISO	NMB designation 	NMB designation 	Da (mm)	di (mm)	ball Ø (mm)	no. of ball bear.	Dyn. C (N)	Stat. C ₀ (N)
1,0160	3,1750	1,1913		RI-2x2		2,56	1,64	0,63500	6	106	28
1,1913	3,9675	1,5875		RI-21/2		3,16	2,05	0,79375	6	158	44
1,1913	3,9675	2,3800			RI-21/2ZZ	3,43	2,05	0,79375	6	158	44
1,3970	4,7625	1,9837		RI-3		4,02	2,36	1,19062	5	264	71
1,3970	4,7625	2,7788			RI-3ZZ	4,29	2,36	1,19062	5	264	71
1,9837	6,3500	2,3800		RI-4		4,90	3,10	1,19062	6	330	99
1,9837	6,3500	3,5712			RI-4ZZ	5,23	3,10	1,19062	6	330	99
2,3800	4,7625	1,5875		RI-3332		4,13	3,00	0,79375	7	187	59
2,3800	4,7625	2,3800			RI-3332ZZ	4,28	3,00	0,79375	7	187	59
2,3800	7,9375	2,7788		RI-5		6,88	4,40	1,58750	6	563	183
2,3800	7,9375	3,5712			RI-5ZZ	7,19	4,40	1,58750	6	563	183
3,1750	6,3500	2,3800		RI-418		5,52	4,10	1,00000	7	285	97
3,1750	6,3500	2,7788			RI-418ZZ	5,85	4,10	1,00000	7	285	97

bore Ø d (mm)	outer Ø D (mm)	width B (mm)	JIS/ISO	NMB designation 	NMB designation 	Da (mm)	di (mm)	ball Ø (mm)	no. of ball bear.	Dyn. C (N)	Stat. C ₀ (N)
------------------------	-------------------------	--------------------	---------	---	---	------------	------------	-------------------	----------------------------	------------------	--------------------------------

3,1750	7,9375	2,7788		RI-518		6,88	4,40	1,58750	6	563	183
3,1750	7,9375	3,5712			RI-518ZZ	7,19	4,40	1,58750	6	563	183
3,1750	9,5250	2,7788		RI-618		6,88	4,40	1,58750	6	563	183
3,1750	9,5250	3,5712			RI-618ZZ	7,20	4,40	1,58750	6	563	183
3,1750	9,5250	3,9675		R-2		7,65	5,08	1,58750	7	641	226
3,1750	9,5250	3,9675			R-2ZZ	8,19	5,08	1,58750	7	641	226
3,9675	7,9375	2,7788		RI-5532		7,08	5,62	1,19062	7	391	142
3,9675	7,9375	3,1750			RI-5532ZZ	7,31	5,62	1,19062	7	391	142
4,7625	7,9375	2,7788		RI-5632		7,08	5,62	1,19062	7	391	142
4,7625	7,9375	3,1750			RI-5632ZZ	7,31	5,62	1,19062	7	391	142
4,7625	9,5250	3,1750		RI-6632		8,72	5,97	1,58750	8	712	271
4,7625	9,5250	3,1750			RI-6632ZZ	8,72	5,97	1,58750	8	712	271
4,7625	12,7000	3,9675		R-3		10,49	7,00	2,38125	7	1306	487
4,7625	12,7000	4,9784			R-3HH	11,00	7,00	2,38125	7	1306	487
6,3500	9,5250	3,1750		RI-614		8,63	7,25	1,00000	13	417	205
6,3500	9,5250	3,1750			RI-614ZZ	8,88	7,25	1,00000	13	417	205
6,3500	12,7000	3,1750		RI-814		10,98	8,38	1,58750	10	828	374
6,3500	12,7000	4,7625			RI-814ZZ	11,55	8,38	1,58750	10	828	374
6,3500	15,8750	4,9784		R-4		13,03	8,20	2,38125	8	1470	599
6,3500	15,8750	4,9784			R-4HH	13,03	8,20	2,38125	8	1470	599
6,3500	19,0500	5,5575		RI-1214		15,19	9,80	3,57188	6	2411	912
6,3500	19,0500	7,1425			RI-1214ZZ	16,28	8,63	3,57188	6	2411	912
7,9375	12,7000	3,9675		RI-8516		11,44	9,20	1,58750	11	878	419
7,9375	12,7000	3,9675			RI-8516ZZ	11,77	9,20	1,58750	11	878	419
9,5250	22,2250	5,5575		RI-1438		18,83	13,22	3,96875	7	3297	1368
9,5250	22,2250	7,1425			RI-1438HH	19,08	12,40	3,96875	7	3297	1368
12,7000	28,5750	6,3500		RI-1812		24,05	17,18	4,76250	8	5113	2387
12,7000	28,5750	7,9375			RI-1812HH	25,13	16,00	4,76250	8	5113	2387

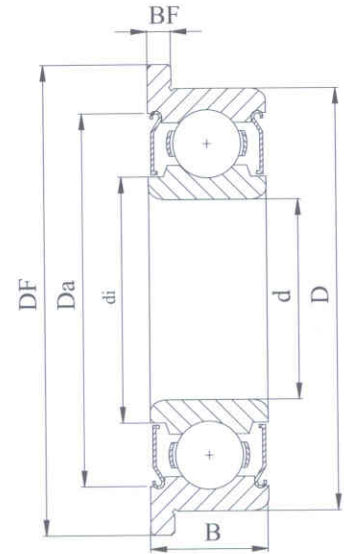
Flanged deep groove single row ball bearings (imperial)



bore \varnothing d (mm)	outer \varnothing D (mm)	width B (mm)	NMB designation 	flange \varnothing D _F (mm)	flange width B _F (mm)	D _a (mm)	d _i (mm)	ball \varnothing (mm)	no. of ball bear.	Dyn. C (N)	Stat. C ₀ (N)
---------------------------------	----------------------------------	--------------------	--	--	---	------------------------	------------------------	----------------------------	----------------------------	------------------	--------------------------------

1,1913	3,9675	2,3800	RIF-21/2ZZ	5,156	0,787	3,43	2,05	0,79375	6	158	44
1,3970	4,7625	2,7788	RIF-3ZZ	5,944	0,787	4,29	2,36	1,19062	5	264	71
1,9837	6,3500	3,5712	RIF-4ZZ	7,518	0,787	5,23	3,10	1,19062	6	330	99
2,3800	4,7625	2,3800	RIF-3332ZZ	5,944	0,787	4,28	3,00	0,79375	7	187	59
2,3800	7,9375	3,5712	RIF-5ZZ	9,119	0,787	7,19	4,40	1,58750	6	563	183
3,1750	6,3500	2,7788	RIF-418ZZ	7,518	0,787	5,85	4,10	1,00000	7	285	97
3,1750	7,9375	3,5712	RIF-518ZZ	9,119	0,787	7,19	4,40	1,58750	6	563	183
3,1750	9,5250	3,5712	RIF-618ZZ	10,719	0,787	7,19	4,40	1,58750	6	563	183
3,1750	9,5250	3,9675	RF-2ZZ	11,176	0,762	8,19	5,08	1,58750	7	641	226
3,9675	7,9375	3,1750	RIF-5532ZZ	9,119	0,914	7,31	5,62	1,19062	7	391	142
4,7625	7,9375	3,1750	RIF-5632ZZ	9,119	0,914	7,31	5,62	1,19062	7	391	142
4,7625	9,5250	3,1750	RIF-6632ZZ	10,719	0,787	8,72	5,97	1,58750	8	712	271
4,7625	12,7000	4,9784	RF-3ZZ	14,351	1,067	11,04	7,00	2,38125	7	1306	487
6,3500	9,5250	3,1750	RIF-614ZZ	10,719	0,914	8,88	7,25	1,00000	13	417	205
6,3500	12,7000	4,7625	RIF-814ZZ	13,894	1,143	11,54	8,38	1,58750	10	828	374
6,3500	15,8750	4,9784	RF-4ZZ	17,526	1,067	13,04	8,20	2,38125	8	1470	599
7,9375	12,7000	3,9675	RIF-8516ZZ	13,894	0,787	11,77	9,20	1,58750	11	878	419
9,5250	22,2250	7,1425	RIF-1438HH	24,613	1,575	19,08	12,40	3,96875	7	3297	1368

Deep groove single row ball bearings with snap ring

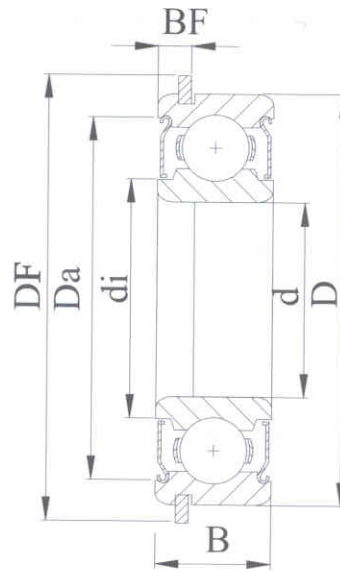

bore Ø d (mm)	outer Ø D (mm)	width B (mm)	JIS/ISO	NMB designation 	DF (mm)	BF (mm)	D _a (mm)	d _i (mm)	ball Ø (mm)	no. of ball bear.	Dyn. C (N)	Stat. C ₀ (N)
------------------------	-------------------------	--------------------	---------	--	------------	------------	------------------------	------------------------	-------------------	----------------------------	------------------	--------------------------------

6	13	5	686ZZNR	LNR-1360X3ZZ	14,5	1,10	10,48	7,7	1,58750	10	831	363
6	15	5	696ZZNR	RNR-1560ZZ	17,2	1,5	13,20	7,8	2,77812	7	1735	671
6	17	6	606ZZNR	RNR-1760X2ZZ	19,2	1,2	14,70	8,22	3,50000	6	2265	839
6	19	6		607ZZNR	22,1	1,5	16,68	9,20	3,50000	7	2614	1053
7	19	6		626ZZNR	22,1	1,5	16,68	9,20	3,50000	7	2614	1053
8	16	5	688ZZNR	LNR-1680HH	18,2	0,95	14,18	9,68	2,38125	9	1606	712
8	22	7		608ZZNRSD03	24,8	2,95	19,10	10,80	3,96875	7	3297	1368
10	22	6	61900ZZNR	RNR-2210X3HH	24,7	1,75	19,40	13,40	3,17500	9	2697	1273
10	26	8		6000ZZNR	29,2	2,31	22,88	13,75	4,76250	7	4578	1970

Material for rings and roller bearing housings

Rings and roller bearing housings are made of very hard, very high purity roller bearing steel in order to be able to withstand even the most extreme stresses. For this reason, only the most carefully-assessed steel suppliers are selected.

NMB Minebea uses chrome steel for rings and roller bearing housings. In cases where resistance to rust is important, stainless steel bearings are used. On request, ceramic roller bearing housings are available for certain types of ball bearing.

NMB Minebea uses high quality, vacuum-degassed chrome steel complying with specification JISG4805/SUJ2 or AISI/SAE 52100 or equivalent. With heat treatment, this steel attains a hardness of 62 to 64 HRC and is thus suited to withstand high stresses over a long service life.

The NMB Minebea developed in-house stainless steel type DD400, when compared with other steel types such as SUS440C/JISG4303/AISI440C, displays improved qualities in respect of hardness, durability and stress resistance. The finer, more even structure of stainless steel DD400 results, in comparison with ordinary stainless steel AISI/440C, in reduced levels of noise. In addition, DD400 has enhanced properties of rust resistance as compared with AISI/440C (according to ASTM-A380).

chrome steel		composition						
standard	designation	C	Si	Mn	P	S	Cr	Mo
JISG4805	SUJ2	0.95-1.10	0.15-0.35	0.5 MAX	0.025 MAX	0.025 MAX	1.3-1.6	–
AISI	52100	0.98-1.10	0.15-0.35	0.25-0.45	0.025 MAX	0.025 MAX	1.3-1.6	–

stainless steel		composition						
standard	designation	C	Si	Mn	P	S	Cr	Mo
–	DD400	0.6-0.75	1.00 MAX	1.0 MAX	0.03 MAX	0.02 MAX	11.50-13.50	0.3 MAX
JISG4303	SUS440C	0.95-1.2	1.00 MAX	1.0 MAX	0.04 MAX	0.03 MAX	16.00-18.00	*

Shields

Covers protect the ball bearing from dirt and moisture penetration, and at the same time prevent the lubricant escaping. The NMB Minebea range covers ball bearings with sealing discs (contact) and cover discs (non-contact).

Non-contact shields

The narrow gap between the inner ring and the cover disc and the maze effect created by the geometry of the inner ring make it difficult for dirt to penetrate from outside. Since there is no contact between inner ring and cover disc, negative effects of any friction are avoided.

Metal shields

Metal shields are made of coated deep-drawn sheet metal or stainless steel and, according to ball bearing type are either pressed into place in the outer ring (not removable, figure A.), or secured in place with a spring clip (removable, figure B).

Rubber seals

Non-contact rubber seals are made of Perbunan® (NBR) with a steel plate insert, and may be used in temperatures of up to 120 °C. The rubber seals are snapped into place in the outer ring of the bearing. The cover gap between the inner ring and the cover disc is much less than in the case of cover discs of metal (figure C).

Contact shields

Contact shields provide very much better protection against the penetration of dirt and moisture. However, through the rubbing contact between inner ring and sealing disc, there are extra frictional influences.

Rubber seals

Rubbing contact rubber seals are also made of Perbunan® (NBR) with a steel plate insert, and may also be used in temperatures of up to 120 °C. The rubber discs are snapped into place in the outer ring of the bearing. The sealing lip lies rubbing against the inner ring (figure D).

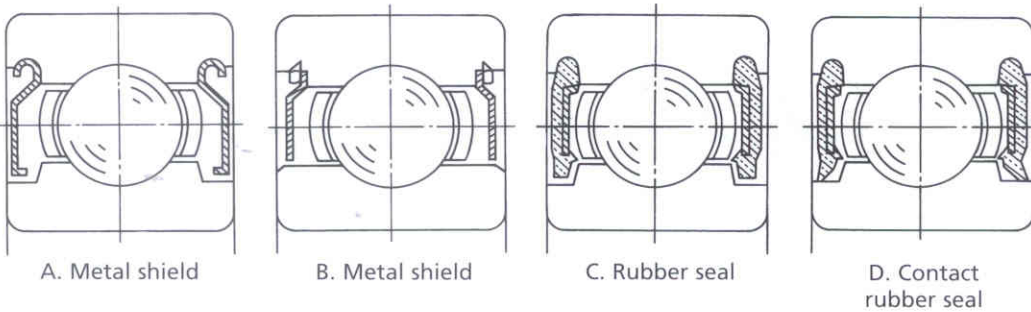

For higher temperature requirements or chemical resistance, sealing discs in HNBR (up to approx. 130 °C), ACM (up to approx. 150 °C), EPDM or Teflon (>200 °C) may also be used. Additionally, it is possible to develop special sealing discs with specific sealing lip geometry for particular applications. In this way, length of service life can be assured even in more polluted environments, or lower rates of lubricant loss. However, such special covers must only be used after consultation with NMB-Minebea.

Shield		NMB PELMEC	NMB M+I	DIN/ISO
Steel seal	Pressed in place	Z	H	Z
	placed (fixed with secur. ring)	-*	Z	Z
Rubber seal	Rubbing	D	D	RS
	Non-contact	S	S	-*
PTFE discs	Rubbing	-*	L	-*

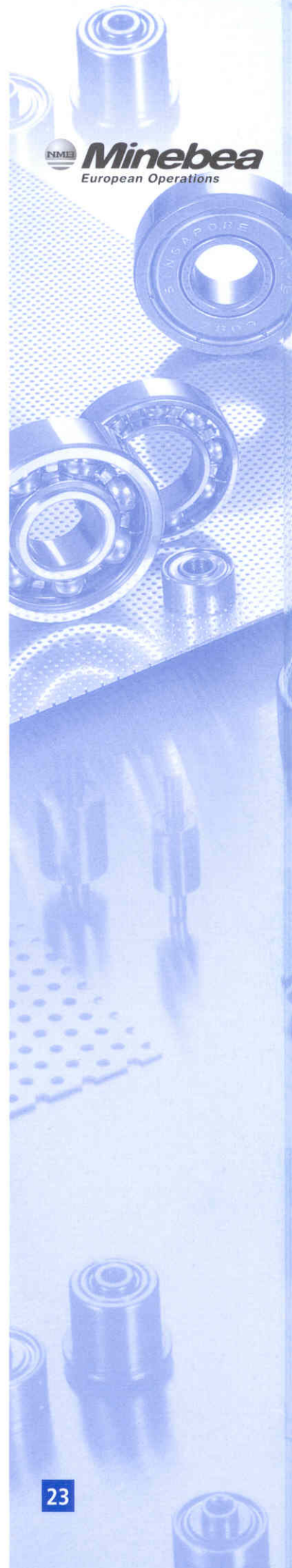

Cages

It is the job of the cage to maintain distances between the bearings and so to prevent additional friction and heat developing, and to distribute the load evenly. Cages are mainly manufactured from steel sheet or plastic.

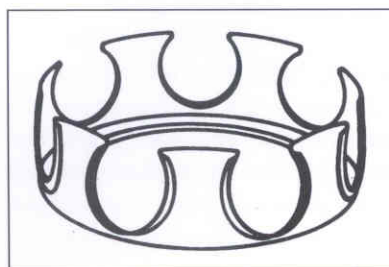

The following types of cage are used:

One-piece snap cage

Inner-ring-led snap-ring cages are used for low to medium speeds, where a very low moment of friction is required. The one-piece snap cage is made of deep-drawn steel sheet and is used primarily in the manufacture of very small types of ball bearings.

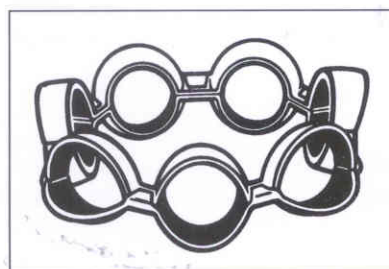

Two-part pressed cage

The two-part pressed cage is also made of deep-drawn steel sheet. It is characterised by its low starting torque and an even friction torque. Due to the simpler automation of the ball bearing assembly, the two-part pressed cage is used for larger series with very high production figures.

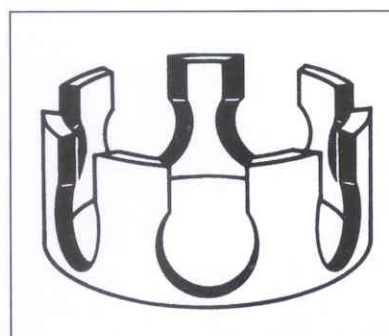

One-piece moulded plastic

The one-piece plastic cage is obtainable in various materials such as fibreglass-reinforced polyamide or polyacetate. As a rule plastic cages for higher-speed applications. Through their emergency running properties, plastic cages also demonstrate advantages when applied in difficult lubrication situations.

Application temperature is restricted according to the material of which the cage is made. Chemical resistance must also be checked beforehand by NMB Minebea.

Type	Material	NMB PELMEC	NMB M+I	DIN/ISO
Two-piece pressed	Steel sheet	without	R	J
snap cage one-piece	Steel sheet	-*	H	JH
	Fibreglass-reinforced polyamide	MN	MN	TNH
	Polyamide	J	M7	TNH
	Polyacetate	-*	J	TNH

Ball bearings tolerances

NMB Minebea ball bearings are manufactured in accordance with JIS B 1514 (ISO 492) or AFBMA. The following symbols are used:

Dimensions:

d	=	nominal bore diameter
D	=	nominal diameter of outer ring
B	=	nominal width of inner ring
C	=	nominal width of outer ring

Variations

Δd_s	=	Variance of an individual bore diameter
Δd_{mp}	=	Variance of the average bore diameter on one plane
ΔD_s	=	Variance of an individual external diameter
ΔD_{mp}	=	Variance of the average external diameter on one plane
ΔB_s	=	Variance of an individual inner ring width
ΔC_s	=	Variance of an individual outer ring width

Fluctuations

VD_p	=	Fluctuation of the outer diameter in an individual radial plane
VD_{mp}	=	Fluctuation of the average external diameter
Vd_p	=	Fluctuation of the bore diameter in one radial plane
Vd_{mp}	=	Fluctuation of the average bore diameter
VB_s	=	Fluctuation of the inner ring width
VC_s	=	Fluctuation of the outer ring width

True-running accuracy

K_{ia}	=	True running of the inner ring of the assembled bearing (radial deviation)
S_{ia}	=	Axial run-out of the inner ring side surfaces to the inner ring slideway of the installed bearing (axial wobble)
S_d	=	Axial run-out of the inner ring side surfaces to the bore (side wobble)
K_{ea}	=	True running of the outer ring of the assembled bearing
S_{ea}	=	Axial run-out of the outer ring side surfaces to the outer ring slideway of the installed bearing
S_D	=	Fluctuation of the inclination of the surface line to the reference lateral surface

Ball bearing tolerances ISO

Tolerances inner ring (bore = 18.0 mm as per ISO standard) - values in μm

tolerance class	Δ_{dmp}		Δ_{ds}		K_{ia}	S_d	S_{ia}	Δ_{BS}		VB_S
	MAX.	MIN.	MAX.	MIN.	MAX.	MAX.	MAX.	OT	UT	MAX.
0	0	-8	-	-	10	-	-	0	-40 ^{*1} -120	12 ^{*1} 15 ^{*2} 20
6	0	-7	-	-	5 ^{*1} 6 ^{*2} 7	-	-	0	-40 ^{*1} -120	12 ^{*1} 15 ^{*2} 20
5	0	-5	-	-	4	7	7	0	-40 ^{*2} -80	5
4	0	-4	0	-4	2.5	3	3	0	-40 ^{*2} -80	2.5
2	0	-2.5	0	-2.5	1.5	1.5	1.5	0	-40 ^{*2} -80	1.5

*1 = Bore $\phi \leq 2,5$ mm - *2 = Bore $\phi \leq 10,0$ mm

Tolerances outer ring ($\phi = 30.0$ mm as per ISO standard) - values in μm

tolerance class	Δ_{Dmp}		Δ_{Ds}		K_{ea}	S_D	S_{ea}	Δ_{CS}		VC_S
	MAX.	MIN.	MAX.	MIN.	MAX.	MAX.	MAX.	OT	UT	MAX.
0	0	-8 ^{*1} -9	-	-	15	-	-	0	*2	* 2
6	0	-7 ^{*1} -8	-	-	8 ^{*1} 9	-	-	0	*2	* 2
5	0	-5 ^{*1} -6	-	-	5 ^{*1} 6	8	8	0	*2	5
4	0	-4 ^{*1} -5	0	-4 ^{*1} -5	3 ^{*1} 4	4	5	0	*2	2.5
2	0	-2.5 ^{*1} -4	0	-2.5 ^{*1} -4	1.5 ^{*1} 2.5	1.5	1.5 ^{*1} 2.5	0	*2	1.5

*1 = Outer $\phi \leq 18.0$ mm

*2= Values see table above

Outer ring tolerance for width is identical with the inner ring tolerances.

Ball bearing tolerances AFBMA

Tolerances inner ring (bore $\leq 18,0$ mm as per AFBMA standard) - values in μm

tolerance class	Δ_{dmp}		Δ_{ds}		K_i	S_{di}	S_i	Δ_{BS}		VB_S
	MAX.	MIN.	MAX.	MIN.	MAX.	MAX.	MAX.	OT	UT	MAX.
1P	0	-8	-	-	10	-	-	0	-40 ^{*1} -120	12 ^{*1} 15 ^{*2} 20
3P	0	-5.1	+2.5	-7.6	5.1 7.6	-	-	0	-127	-
5P	0	-5.1	0	-5.1	3.8	7.6	7.6	0	-25.4	5.1
7P	0	-5.1	0	-5.1	2.5	2.5	2.5	0	-25.4	2.5
9P	0	-2.5	0	-2.5	1.3	1.3	1.3	0	-25.4	1.3

*1 = Bore $\phi \leq 2,5$ mm *2 = Bore $\phi \leq 10,0$ mm

Tolerances outer ring ($\phi = 30,0$ mm as per ISO standard) - values in μm

tolerance class	Δ_{Dmp}		Δ_{Ds}				K_e	S_D	S_e	Δ_{CS}		VC_S
	MAX.	MIN.	offenes Lager		geschl. Lager		MAX.	MAX.	MAX.	OT	UT	MAX.
1P	0 0	-8 ^{*1} -9	-	-	15	-	-	-	-	0	*2	*2
3P	0	-7.6	+2.5	-10.2	+5.1	-12.7	10.2	-	-	0	-127	-
5P	0	-5.1 ^{*1}	0	-5.1	+1	-6.1	5.1	7.6	7.6	0	-25.4	5.1
7P	0	-5.1	0	-5.1	+1	-6.1	3.8	3.8	5.1	0	-25.4	5.1
9P	0 0	-2.5 ^{*1} -3.8	0	-2.5 ^{*1} -3.8	-	-	1.3 ^{*1} 2.5	1.3	1.3 ^{*1} 2.5	0	-25.4	1.3

*1 = Outer $\phi \leq 18,0$ mm

*2= Values see table above

Outer ring tolerance for width is identical with the inner ring tolerances.

Corner radii

The exact shape of the corner profile for the bearings is not laid down. It is restricted solely by the minimum and maximum corner radii and the arc r_{smin} (see DIN 620).

Values in μm

r_{smin}	d		r_{smax}		r_{amax} Bore Housing Shaft \varnothing
	$>$	\leq	Radial direction	Axial direction	
0.05	-	-	0.1	0.2	0.05
0.08	-	-	0.16	0.3	0.08
0.1	-	-	0.2	0.4	0.1
0.15	-	-	0.3	0.6	0.15
0.2	-	-	0.5	0.8	0.2
0.3	-	40	0.6	1.0	0.3
0.6	-	40	1.0	2.0	0.6

The exact shape of the corner profile is not laid down, but seen in radial section should lie within the arc shown in the following diagram.

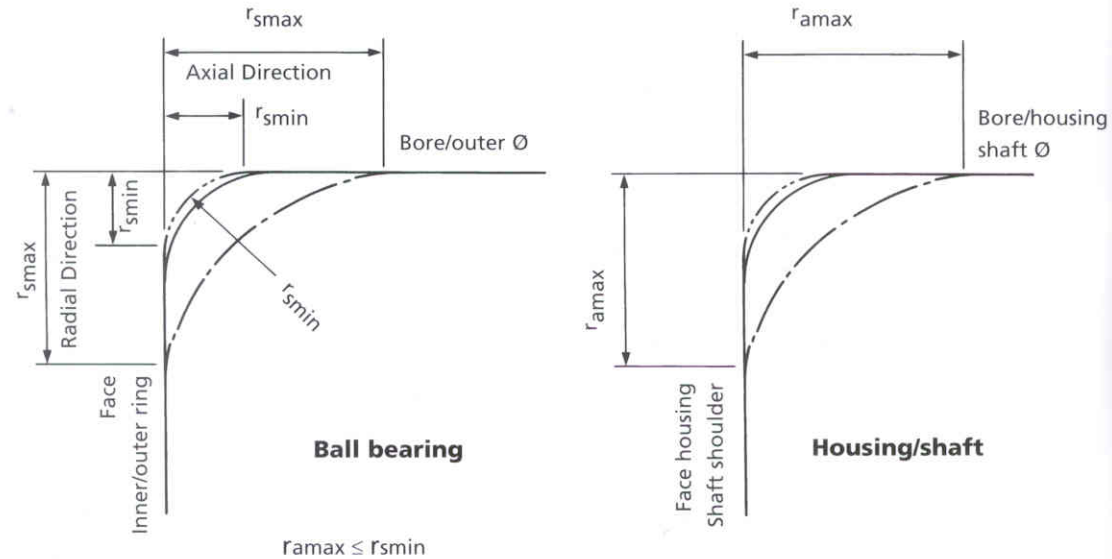

Bearing clearance

Bearing clearance is an extremely important characteristic. The right choice has a critical effect on the service life, the running noise, vibration and temperature behaviour of a ball bearing. For this reason, it is necessary to select the right bearing clearance class beforehand, in accordance with the installation and application circumstances.

Bearing clearance may be affected either by pressure applied on the outer or inner ring, according to the type of installation selected. Bearing clearance in the uninstalled bearing is therefore separated into various bearing clearance classes. Standard values for ball bearing radial clearances are laid down in DIN 620. However, by comparison with DIN, NMB Minebea uses a more exacting classification with substantially reduced tolerances.

NMB Minebea manufactures the ball bearings for two different product sectors. Pure M+I ball bearings (Miniature and Instrument ball bearings) with relatively small production figures, primarily for instrument manufacture, and Pelmeq ball bearings with ISO designation for larger series productions. Each of these product sectors use different designation systems for ball bearing clearance classes.

Radial designation for M+I ball bearings in μm

Radial play	P13	P24	Standard P25	P35	P58
Value in μm	3-8	5-10	5-13	8-13	13-20

Radial designation for ISO ball bearings in μm

Radial play	M2	Standard M3	M4	M5	
Value in μm	3-8	5-10	8-13	13-20	

As further characteristics, axial play and tilt angle can also be of interest. Axial play is not standardised, but can play an important role when for example establishing the overall axial play of a motor driving shaft. The maximum tilt angle is a product of the inner bearing geometry and the bearing clearance in installed position. The maximum tilt angle influences maximum permissible alignment errors in the bearing system.

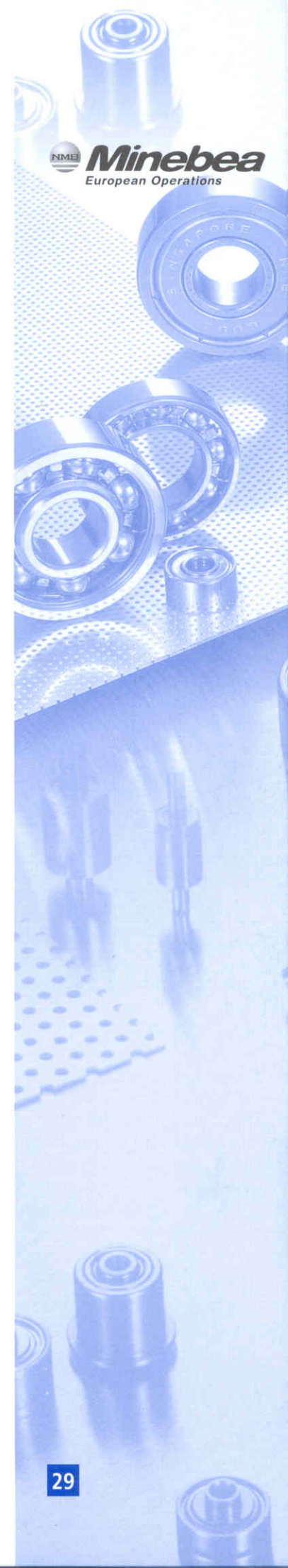
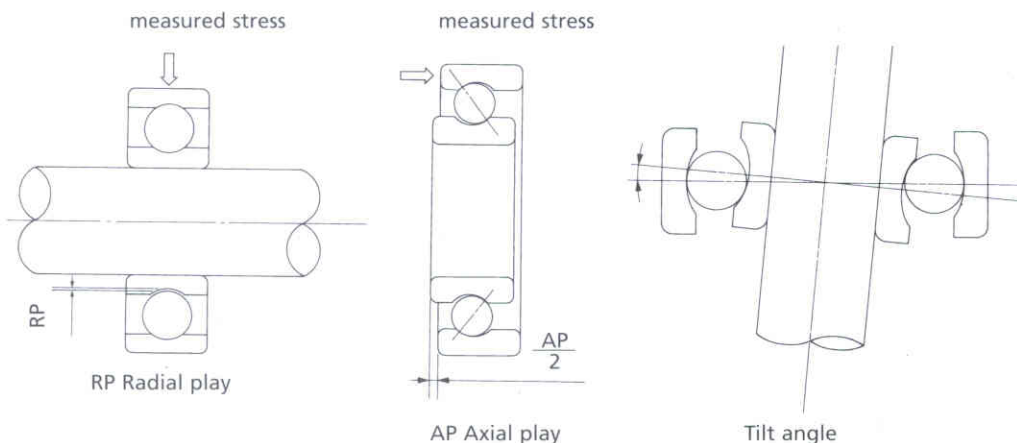

Lubrication

Imperative for the service life of ball bearings is the right lubricant. Choice of the right lubricant will also be a decisive influence on operating noise, friction, speed of rotation and protection against corrosion.

Generally speaking, all NMB ball bearings are protected by a corrosion-resistant oil.

Enclosed NMB ball bearings are greased ex works and therefore lubricated for life. Open ball bearings are normally oiled.

The major advantages of grease lubrication are the good sealing effect against penetration of dirt from outside, low level of maintenance required (lifetime lubrication) and the damping effect on operating noise. Oil lubrication is ideal for gearing which is already oil-lubricated, or in applications where a very low friction torque is required. Choice of the most suitable lubricant depends on the application parameters. These are primarily the operating temperature, such environmental influences as moisture and dust, and noise requirements. In the following lubrication chart a selection of the standard oils and greases available from NMB are listed. Other lubricants are also available at the customer's request.

NMB Code	Product name	Basic oil/ thickener	Basic oil viscosity	Tempe- rature range	Application purpose	Typical application
			40/100°C	0°C		
L01	L-245X	.../diester oil	11,8/3,5	-50 +120	Instrument oil Rust protection	Rust protection (open bearing)
LY72	Multemp PS No.2	Lithium / mineral oil	15,3/3,7	-50 +120	Low friction torque	Deflection roller, friction-sensitive motors
LY121	Multemp SRL	Lithium / diester oil	26/5,1	-40 +130	Standard lubricant for NMB ball bear.	Noise-critical applications with wide range of uses
LY342	Asonic GLY 32	Lithium / diester oil, synthetic HC	25/5	-50 +140	Wide range of uses	Noise-critical applications with wide range of uses
LY530	Asonic Q 74-73	Polycarbamide / diester oil, synth. HC	68/10	-40 +160	Standard lubricant for the automotive industry	Automotive applications
LY532	Asonic HQ 72-102	Polycarbamide / diester oil,	10/12	-40 +170	Medium / higher temperature appl.	Automotive applications
LY551	Multemp K37	Polycarbamide / PAO	47,6/7,9	-40/+160	Dirtier environment	Vacuum cleaner fans / electric tools
LY655	Noxlube KF2120	Ester / PTFE	210/36	-40 +200	Only for high- temperature appl.	Hot air blowers

Lubricant quantities

As a rule, in the case of greased bearings, 30 % of the unfilled space is filled with lubricant. By request, however, varying amounts of lubricant may also be used. The following suffixes are used to indicate the amount of lubricant in ball bearings:

L = 10 - 15 % T = 15 - 20 % No Code 25 - 35% H = 40 - 50 %

Service life – static loadability

Service life

The standardised calculation process as per DIN ISO 281 for dynamically-stressed ball bearings is based on material fatigue as the reason for failure. Here, the value Lh10 expresses the nominal service life which at least 90 % of a large number of similar bearings must attain or exceed.

The nominal service life is calculated as follows:

$$\text{The formula Lh10 } \frac{10^6}{n \cdot 60} \left(\frac{C}{P} \right)^3 \text{ [h]}$$

Lh10	=	nominal service life [h]
C	=	dynamic carrying figure [N]
P	=	dynamic equivalent loading
p	=	service life exponent (p = 3 for ball bearings)
n	=	rotation number [min-1]

The dynamic equivalent loading P for ball bearings is a mathematical value which converts existing radial and axial loading on the ball bearing into a constantly operative radial loading. The dynamic carrying figure C is taken from the corresponding table in the ball bearing catalogue.

$$P = X * Fr + Y * Fa$$

where

P	=	dynamic equivalent loading
Fr	=	radial loading
Fa	=	axial loading
X	=	radial factor
Y	=	axial factor

Values for the factors X, Y are taken from the calculating procedure according to DIN ISO 281.

Static loadability

Under high static stresses, there develop on roller bearings and the roller bearing rollerways permanent deformations. Experience shows that a permanent total deformation of 0.00001 times the diameter of the bearing at the central point of the most heavily-loaded contact point between bearing and rollerway may be permitted in most applications without impairment of the operating efficiency of the bearing. The static bearing figure is thus set so high that this deformation occurs approximately when the equivalent static loading is equivalent to the static bearing figure.

The static equivalent loading P_O for ball bearings is a mathematical value which converts the existing radial and axial loadings on the ball bearing to a constantly-operative radial loading. The static carrying figure C_O is taken from the corresponding table in the ball bearing catalogue.

$$P_O = X_O * Fr + Y_O * Fa$$

P _O	=	static equivalent loading
Fr	=	radial loading
Fa	=	axial loading
X _O	=	radial factor = 0.6 for ball bearings
Y _O	=	axial factor = 0.5 for ball bearings

Values for the factors X, Y are taken from the calculating procedure according to DIN ISO 76.



Pre-stressed / bearing adjustment

In order to achieve operation as near noiseless as possible, in most applications, two ball bearings are installed in contact with one another (pre-stressed). Pre-stressing is actually accomplished by spring elements. The elastic nature of the pre-stressing equalises out temperature variations during operation. In addition, vibration and stationery shocks are lessened.

Optimum pre-stressing must be calculated for each and every application. If pre-stressing is high, there will be increased friction torque and an increase in temperature which will lead to a decreased service life. On the other hand, if the pre-stressing is too low, this will lead to problems with friction corrosion, fretting corrosion, vibration and thus to noisier operation. NMB-Minebea recommends that the pre-stressing is introduced over the non-rotating ring of the ball-bearing (inner or outer ring). This will prevent frictional corrosion occurring because of relative movement between the rotating parts. The rotating ring should be fixed by a press-fit. For the majority of applications, this means that with the shaft rotating the inner ring of the bearing will be fixed with a press-fit. The pre-stressing should then be introduced over the outer ring with a spring element, e.g. a three-pointed corrugated washer (see sketch).

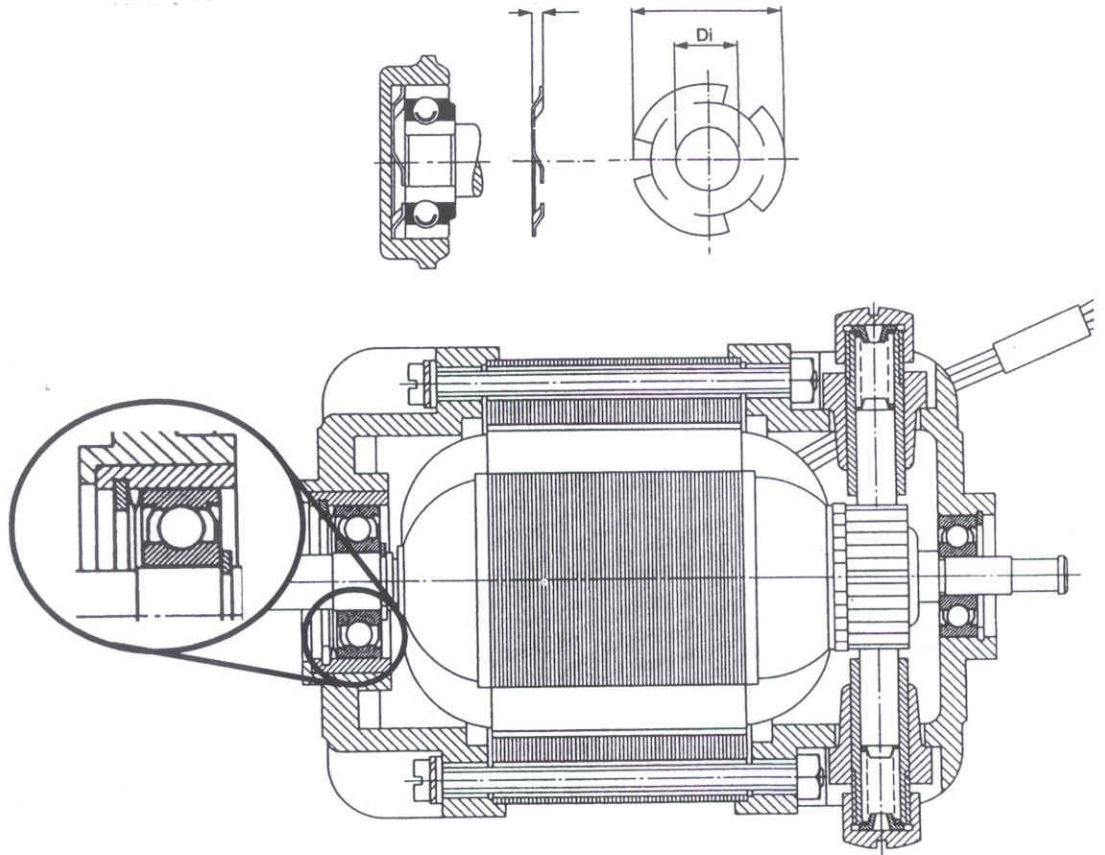

Installation tolerances

Ball bearings are fixed, according to the external forces, in radial and axial direction on the shaft and in the housing. The fixing may be achieved either by means of force-fit or bonding, or by shape-fit (safety washers or safety discs).

Operationally-dependent heat expansion of various types of shafts and motor components will lead to inner stresses on the bearings when neither of the bearers is arranged to have play, and be displaceable (loose bearing).

As a rule, the rotating ring of the ball bearing will be provided with a fixed seating. DIN 5425 gives instructions regarding the bearing fixing and degree of accuracy of the adjustment. In the case of thin-walled ball-bearings, the DIN details should not simply be followed. We will be happy to advise you on the ideal choice of installation tolerances and fixing the bearings.

Handling ball bearings

Ball bearings are precision components and a great deal of care and technology goes into ensuring that their manufacture and packaging meet high standards of cleanliness. Moisture, particles of dirt, metal filings and other foreign bodies, once they penetrate the bearing, can substantially affect the running qualities, silent running behaviour and the service life of a bearing. For this reason, ball bearings must be treated correspondingly carefully in their use.

It is essential that the following points are observed:

- Leave the bearing in its original packaging until it is time to use it - it is not a waste-basket!
- After removing it, reseal the original packaging
- Keep the installation location clean - no chips, filings, dust etc.
- Bearing seatings must be clean and free of swarf, etc.
- Check assembly tools regularly
- Only use force on the ring to be installed
- Do not lay the bearings on highly-absorptive surfaces
- Do not blow the bearing clean with compressed air
- Use no chemicals in the vicinity (gases, vapours, liquids)

When using adhesives, problems with endurance of the lubricant may sometimes occur. This relates particularly to products which contain cyano-acrylates.

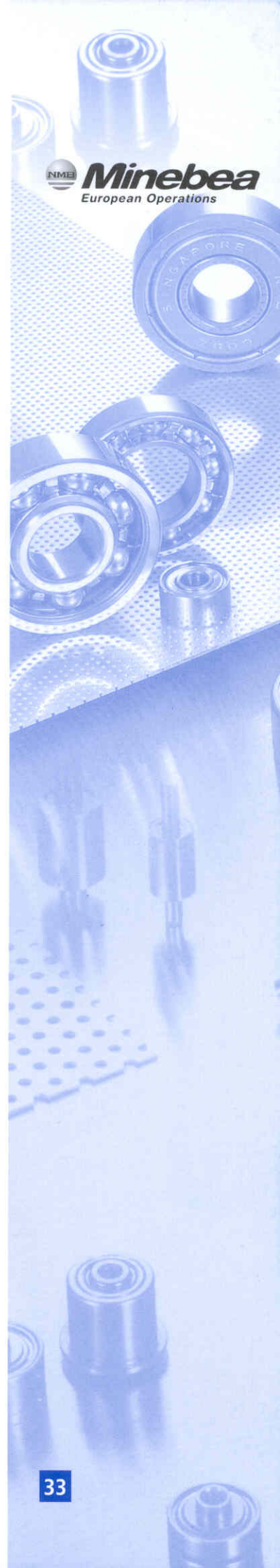

Mechanical components

As the world's largest manufacturer of miniature ball bearings, it is appropriate that we should manufacture ball bearing components with the highest precision. NMB Minebea manufactures such components on state-of-the-art manufacturing equipment. Planning, manufacturing and testing procedures are all carried out in house by ourselves. For example, all tools, turned and moulded parts we make ourselves. Assembly of the mechanical components is all undertaken in clean rooms which meet the most exacting standards of cleanliness.



Mechanical components (assemblies)

Since mechanical components are always developed and manufactured for one specific customer, close contact with the customer is an absolute essential for carrying out the project successfully. That there is intensive co-operation between the application engineers and sales engineers of NMB Minebea and the customer really goes without saying.

Primarily, small and very precise components are manufactured for all applications. Thus you will find shaft encoders, roller conveyors, injection-moulded impellers and components for the PC and automation industry in the NMB Minebea product range.

NMB Minebea's production capacity makes it possible for us to take on the manufacture of both small orders and large series with major production quantities.

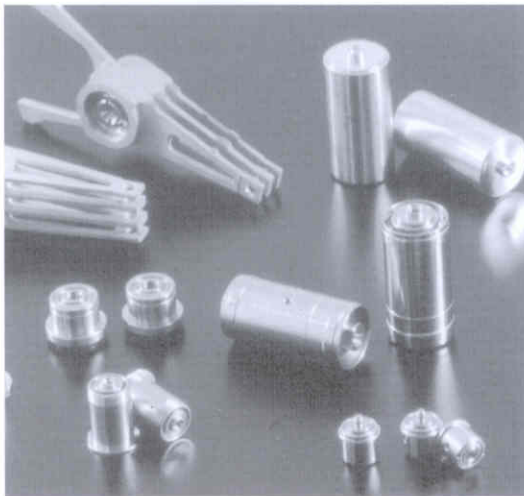
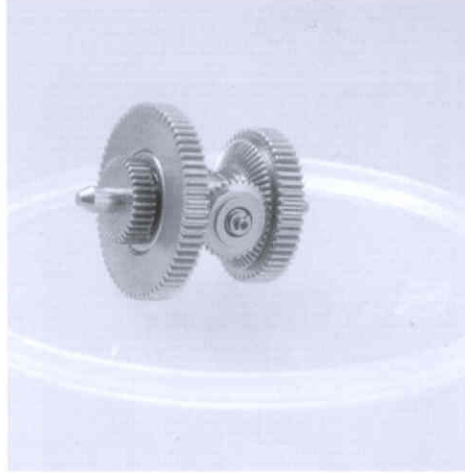
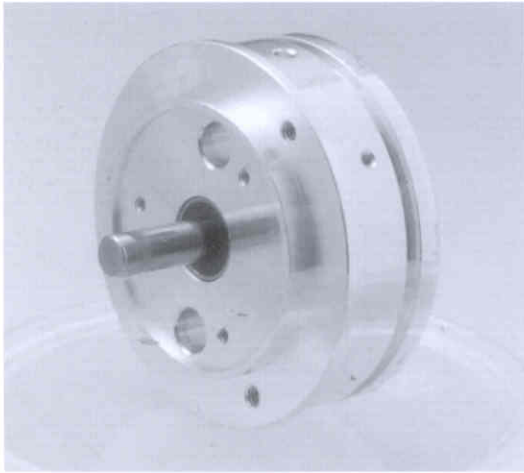

Engineering support

It is NMB Minebea's aim to give its customers optimal support right through the project phase and series production. To this end, our sales and applications engineers offer you the service at your premises. You will continue to receive individual answers to all organisational and commercial questions from our team indoors. Alongside the usual services such as provision of quotations, sampling, service life calculations and preparation of drawings, we also support our customers in the new developments sector with ball bearing analyses during or after the field trials.

Assessment and report preparation is carried out in our German sales office in Langen. This is the location of our central ball bearing laboratory for Europe, which is equipped with the most important analysis equipment and measuring devices. This guarantees very quick and flexible carrying out of the analysis. For detailed material and lubricant analysis, we have available the development centres of NMB around the world, in Japan, Thailand, Singapore and the USA.

By arrangement with our customers, we can carry out preliminary tests or endurance tests on our own NMB test benches. For this purpose, our Schwarzwald location is equipped with a modern test bench which also means individual field trials can be carried out.

Naturally enough, we also support our customers in investigating failures, or manufacturing problems. In close co-operation with the staff onsite, manufacturing analysis is often a decisive factor in early recognition of problems and avoiding later failures.

Training measures covering the whole subject of ball bearings - either with us or directly at the customer's premises - round off the range of services we offer.

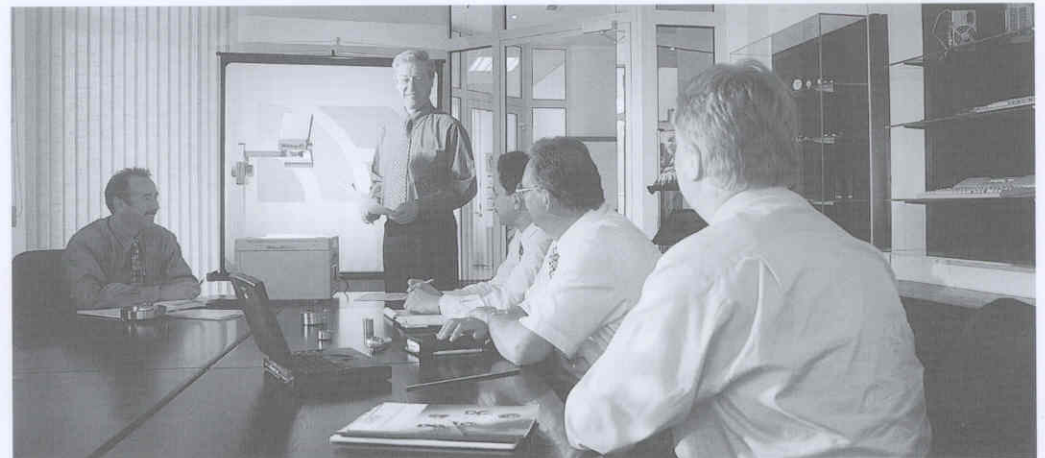
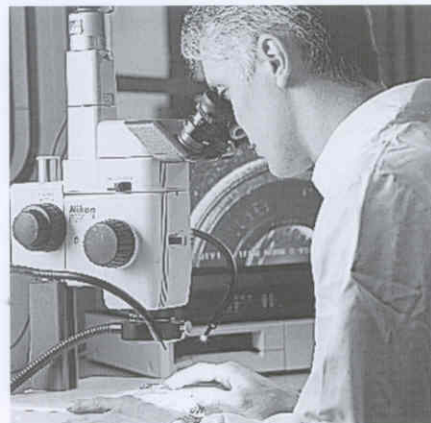

Sample copy for request form • Fax to: +49 (0) 6103 913 328

Company		Date		
Street/No.		Factory		
Town/Postcode		Telefon		
Name/Department		Fax		
Your parts No./project name				
Application/details				
Annual needs		Stk./Jahr	Start of series production	
Service life product		No. of bearings/application		
NMB part numbers				
If NMB part unknown, please complete the following fields and/or enclose data sheet/drawing				
Material	<input type="checkbox"/> Chrome steel	<input type="checkbox"/> Stainless steel	<input type="checkbox"/> Hybrid bearing	
Bore \varnothing	mm	<input type="checkbox"/> Cover disc	<input type="checkbox"/> Flange bearing	Flange \varnothing mm
Outer \varnothing	mm	<input type="checkbox"/> Sealing disc		Flange width mm
Width	mm	<input type="checkbox"/> Open	Radiale clearance	from to μm
Tolerance class		Lubricant		
Rotation speed		Usual service life h.	Inner ring rotation	Outer ring rotation
Rotation type	<input type="checkbox"/> Continuous	<input type="checkbox"/> Reversing	<input type="checkbox"/> Oscillating	Oscillating angle
Temperature range		Working temp.		
From $^{\circ}\text{C}$	To $^{\circ}\text{C}$	$^{\circ}\text{C}$	<input type="checkbox"/> Dust	<input type="checkbox"/> Humidity %
F_R	N	F_{1A}	N	
F_A	N	F_{1R}	N	
F_i	N	F_{2A}	N	
a	mm	F_{2R}	N	
b	mm	<input type="checkbox"/> Continual		
c	mm	<input type="checkbox"/> Shock		
Pre-stressing		N		
Acts on	<input type="checkbox"/> Inner ring			
	<input type="checkbox"/> Outer ring			
Shaft material		Roughness	Rz/Ra μm	tolerance
Housing material		Roughness	Rz/Ra μm	tolerance
Shaf /bearing fit	House/bearing fit		Sketch: please sketch shaft, housing and securing elements or springs etc., drawings if appropriate.	
<input type="checkbox"/> Force fit	<input type="checkbox"/> Force fit			
<input type="checkbox"/> Sliding fit	<input type="checkbox"/> Sliding fit			