

2007/06/29 18:56:14 SROper

参考図：ご確認用。正式には別途納入仕様書をご請求願います。

TO
R

COUNT	DESCRIPTION OF REVISIONS	BY	CHKD	DATE	COUNT	DESCRIPTION OF REVISIONS	BY	CHKD	DATE
△					△				
△					△				
APPLICABLE STANDARD									
RATING	OPERATING TEMPERATURE RANGE	-25 °C TO +85 °C			STORAGE TEMPERATURE RANGE	-25 °C TO +85 °C			
	VOLTAGE	AC 125 V, DC 175 V			WIRE SIZE	MAX AWG#20			
	CURRENT	5 A			APPLICABLE CABLE	—			
SPECIFICATIONS									
ITEM		TEST METHOD			REQUIREMENTS			QT	AT
CONSTRUCTION									
GENERAL EXAMINATION		VISUALLY AND BY MEASURING INSTRUMENT.			ACCORDING TO DRAWING.			○	○
MARKING		CONFIRMED VISUALLY.						○	○
ELECTRIC CHARACTERISTICS									
CONTACT RESISTANCE		CONTACT SHALL BE MEASURED AT DC 1 A			15 mΩ MAX.			○	○
		CONTACT SHALL BE MEASURED AT DC — A			— mΩ MAX.			—	—
INSULATION RESISTANCE		500 V DC.			1000 MΩ MIN.			○	○
VOLTAGE PROOF		1250 V AC FOR 1 min.			NO FLASHOVER OR BREAKDOWN.			○	○
MECHANICAL CHARACTERISTICS									
CONTACT INSERTION AND WITHDRAWAL FORCES		— BY STEEL GAUGE.			INSERTION AND WITHDRAWAL FORCES : — N MIN.			—	—
CONNECTOR INSERTION AND WITHDRAWAL FORCES		MEASURED BY APPLICABLE CONNECTOR WITHOUT LOCKING DEVICE.			INSERTION AND WITHDRAWAL FORCES : 25 N MAX.			○	—
MECHANICAL OPERATION		1000 TIMES INSERTIONS AND EXTRACTIONS.			CONTACT RESISTANCE: 30 mΩ MAX. — RESISTANCE: — mΩ MAX.			○	—
VIBRATION		FREQUENCY: 10 → 55 → 10 (Hz) (1CYC, 5min), SINGLE AMPLITUDE 0.75 mm, AT 10 CYC, FOR 3 DIRECTIONS.			①NO ELECTRICAL DISCONTINUITY OF 10 μs. ②NO DAMAGE, CRACK AND LOOSENESS OF PARTS.			○	—
SHOCK		IN OPPOSITE DIRECTIONS OF EACH 3 DIMENSION AXIS FOR 3 TIMES AT 490 m/s ² DURATIONS OF PULSE 11 ms.			①NO ELECTRICAL DISCONTINUITY OF 10 μs. ②NO DAMAGE, CRACK AND LOOSENESS OF PARTS.			○	—
BREAKING STRENGTH		MAX 100 N SHALL BE APPLIED TO CABLE IN UP AND DOWN, LEFT AND RIGHT DIRECTIONS WHEN MATED.			NO BREAKAGE MAX 100N.			○	—
ENVIRONMENTAL CHARACTERISTICS									
DAMP HEAT (STEADY STATE)		EXPOSED AT 40 °C, 90 TO 95 %, 96 h.			①INSULATION RESISTANCE: 10 MΩ MIN (AT HIGH HUMIDITY). ②INSULATION RESISTANCE: 100 MΩ MIN (AT DRY). ③NO DAMAGE, CRACK AND LOOSENESS OF PARTS.			○	—
RAPID CHANGE OF TEMPERATURE		TEMPERATURE -55 → R/T ⁽¹⁾ → +85 → R/T °C TIME 30 → 2 TO 3 → 30 → 2 TO 3 min UNDER 5 CYCLES.			①INSULATION RESISTANCE: 100 MΩ MIN. ②NO DAMAGE, CRACK AND LOOSENESS OF PARTS.			○	—
CORROSION SALT MIST		EXPOSED IN 5 % SALT WATER SPRAY FOR 48 h.			NO HEAVY CORROSION.			○	—
DRY HEAT		EXPOSED AT +85 °C, 96 h.			NO DAMAGE, CRACK AND LOOSENESS OF PARTS.			○	—
COLD		EXPOSED AT -55 °C, 96 h.			NO DAMAGE, CRACK AND LOOSENESS OF PARTS.			○	—
RESISTANCE TO SOLDERING HEAT		SOLDER TEMPERATURE, +350±10°C, FOR IMMERSION DURATION, 5±1 s.			NO DEFORMATION OF CASE OF EXCESSIVE LOOSENESS OF THE TERMINALS.			○	—
SOLDERABILITY		SOLDERED AT SOLDER TEMPERATURE, +350±10°C FOR IMMERSION DURATION, 2 TO 3 s.			SOLDER SURFACE TO BE FREE FROM PIN-HOLE, NO WETTING AND OTHER DEFECTS.			○	—
SEALING		EXPOSED AT A DEPTH OF 1.8 m FOR 48 h.			NO WATER PENETRATION INSIDE CONNECTOR.			○	—
AIR TIGHTNESS		APPLY AIR PRESSURE 17.6kPa FOR 0.5min TO INSIDE CONNECTOR.			NO AIR BUBBLES INSIDE CONNECTOR.			○	○
REMARKS				DRAWN	DESIGNED	CHECKED	APPROVED	RELEASED	
NOTE(1) R/T : ROOM TEMPERATURE Unless otherwise specified, refer to JIS C 5402.				<i>K. Imai</i>	<i>...</i>	<i>...</i>	<i>...</i>	<i>...</i>	
Note QT:Qualification Test AT:Assurance Test O:Applicable Test									
HRS HIROSE ELECTRIC CO., LTD.				SPECIFICATION SHEET			PART NO. LF07WBR-3P		
CODE NO. (OLD) CL		DRAWING NO. ELC4-114148			CODE NO. CL136-1003-2			1/1	



5				6				7				8			
COUNT	DESCRIPTION OF REVISIONS	BY	CHKD	DATE	COUNT	DESCRIPTION OF REVISIONS	BY	CHKD	DATE	COUNT	DESCRIPTION OF REVISIONS	BY	CHKD	DATE	
△					△					△					
△					△					△					
△					△					△					

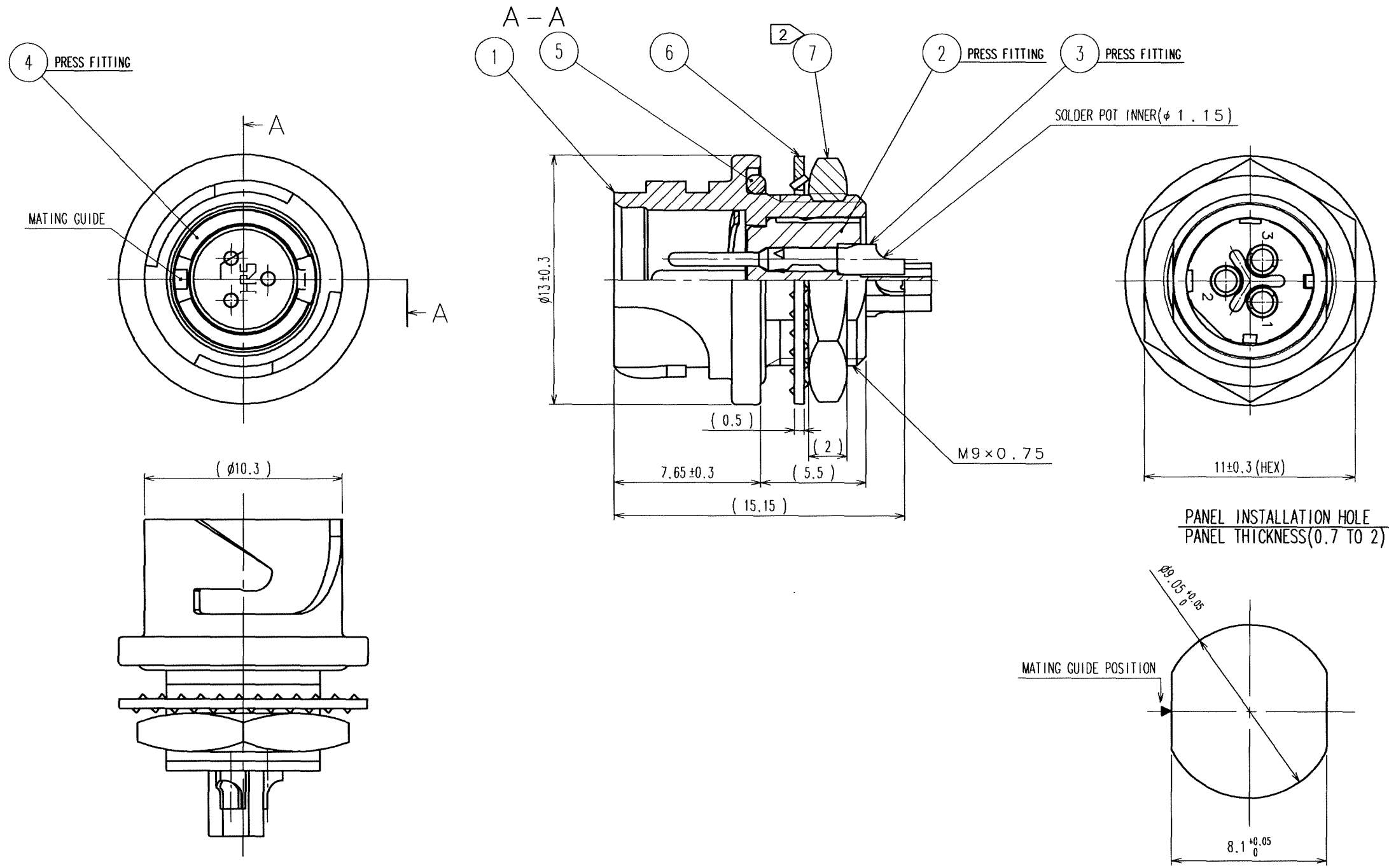

- NOTES
- ① PLATING(REF.NO.③)
CONTACT AREA : GOLD 0.2 μ m min
OTHERS : GOLD AND NICKEL
UNDER PLATING : NICKEL 2 μ m min
 - ② THE RECOMMENDED CLAMP TORQUE OF REF.NO.⑦ TO BE 1.5 TO 2N·m.
THREAD LOCKER TO THE THREADED PORTION OF REF.NO.① IS RECOMMENDED TO PREVENT REF.NO.⑦ FROM LOOSING.
RECOMMENDED THREAD LOCKER:LOCTITE 271, HENKEL JAPAN LTD.
 - ③ WHEN THIS CONNECTOR IS MOUNTED ON TO PANEL, BE CAREFUL REF.NO.⑤ IS ASSEMBLED SURELY INTO THE GROOVE OF REF.NO.① AS SHOWN IN THIS FIGURE TO KEEP WATERPROOF EFFECTIVENESS.

4	PHOSPHOR BRONZE	NICKEL PLATING						
3	COPPER ALLOY	①	7	STEEL	NICKEL PLATING			
2	PPS	(BLACK) UL94V-0	6	STEEL	NICKEL PLATING			
1	ZINC ALLOY	NICKEL PLATING	5	CHLOROPRENE RUBBER	(BLACK)			
NO.	MATERIAL	FINISH, REMARKS	NO.	MATERIAL	FINISH, REMARKS			
CODE NO. (OLD) CL			DRAWN	DESIGNED	CHECKED	APPROVED	RELEASED	
			<i>k.abe</i>	<i>H.Zembo</i>	<i>M.Sato</i>	<i>M.oguchi</i>		
			09.10.25	09.10.25	04.10.26	09.10.26		
DRAWING NO. EDC3-114148			PART NO. LF07WBR-3P					
SCALE 4 : 1			CODE NO. CL136-1003-2				1/1	
UNITS mm			HRS HIROSE ELECTRIC CO., LTD					