

Aluminum Roller Guides

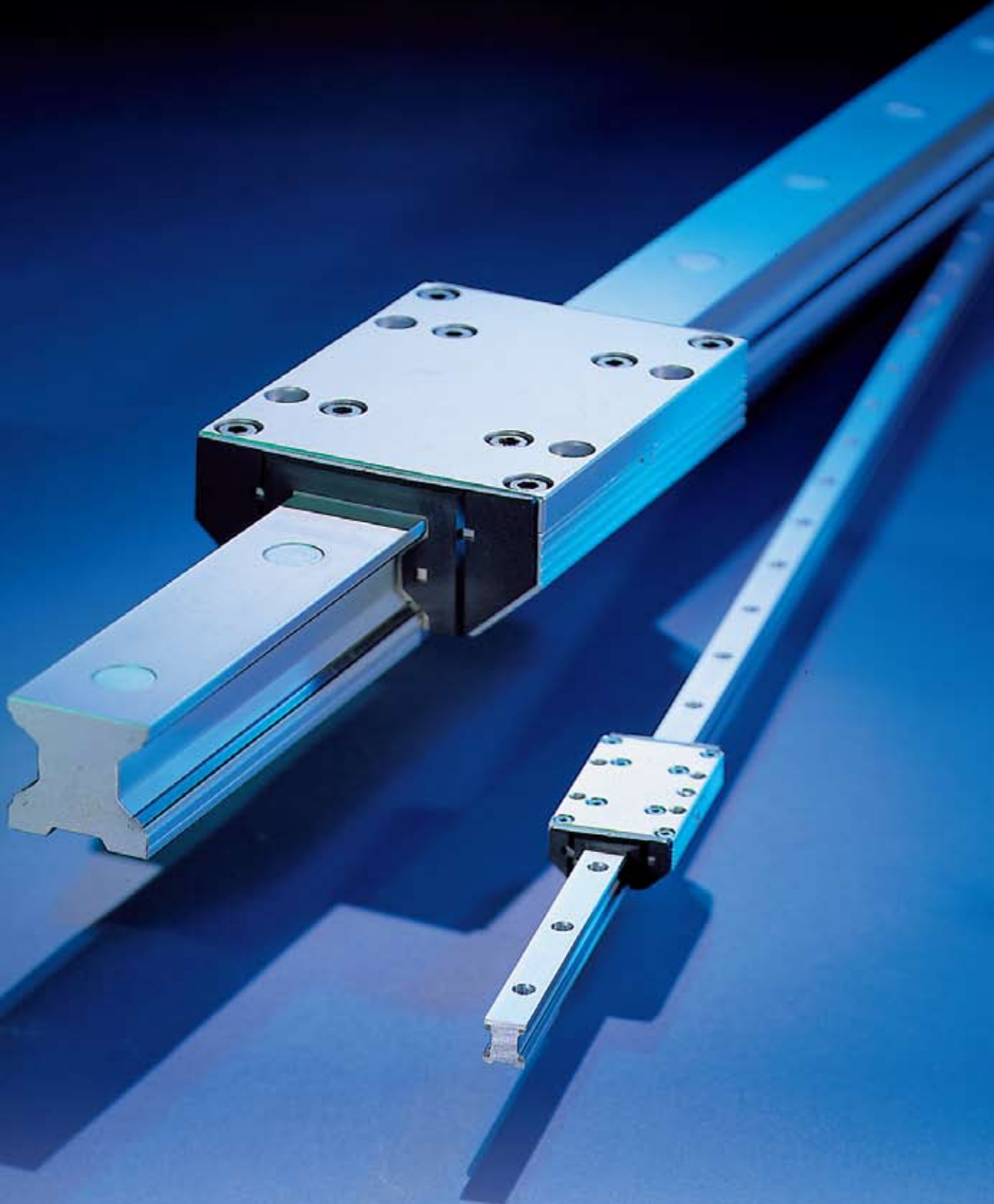



Table of Contents

	Page
The Guideline Concept	2
The Guideline System	3
GDL Product Line Overview	4
Descriptions of the various GDL Series available	4
GDL linear guide detail drawings, various series offered and dimensions	5
Cassette & rail load and moment ratings and component weight data	6
End of stroke stop screws and rail mounting screw covers	7
Snap-on full profile wiper kits and keyed butt-jointed rail option	8
Units conversion Table	9
GDL Technical information	10-13
GDL rail/cassette part numbering schemes for ordering	14-15
GDL Application Sheet	16

**The Guideline
Concept**

GDL ALUMINUM ROLLER GUIDES: LIGHT, SMOOTH AND FAST

Aluminum roller guides in a cutting machine for spectacle lenses. Both the work piece carriers and the motorized X - Y table axis are equipped with roller guides. The smooth operation and precision of the equipment ensures a fine cutting action.



Aluminum roller guides in an automatic vibrator for flattening printed sheets of paper. To guarantee even pressure on the sheets of paper, the roller bridge is supported by precision roller guides. (Baumann company photo)



Handling units for medical equipment. Smooth, easy movement with guideline roller guides. (Dräger company photo)



Aluminum roller guides in the sliding carriage of a machine for producing cables. The projecting arm of the carriage is guided by two double rails each with two roller cassettes and can be moved manually with minimal force because of the low friction properties. (Kabelmat company photo)



Single rail and roller shoe versions of the aluminum roller guide in a handling arrangement for stacks of paper. Various fittings and limit stops for stacking are moved on two axes horizontally and vertically. The robustness and reliability of the roller guides allows for continuous operation under high load conditions. (Solms company photo)



- Light weight (anodized aluminum)
- Smooth and quiet operation
- Speeds up to 10 m/s
- Acceleration/deceleration up to 40 m/s²
- Loading from any direction
- Permanently lubricated guidance system
- Broad product range in various series High Performance, Standard and Stainless Steel Versions
- High load and moment capacities
- Very cost effective
- Flexible mounting dimensions



GDL LINEAR GUIDES OFFER A VARIETY OF SERIES AND OPTIONS — HIGH PERFORMANCE... “SMOOTH GUIDANCE”

Aluminum roller guides provide smooth operation and high load carrying capacity for industrial automation.

By the use of lightweight aluminum components the moving masses are minimized, travel speeds are increased and actuation energy is saved.

Aluminum roller guides are designed to carry medium weight loads economically. Their smooth action and speeds up to 10 m/s make them ideal for widespread use in many areas of application.

Aside from a main featured High Performance guide, others such as the Standard, Corrosion Resistant, High Dynamics and Grease-free versions are also available.

Aluminum roller guides are available in sizes 12, 15, 20, 25, 35 and 45mm. Rail lengths are from 200 mm to 4000 mm. For longer travel lengths, guide rails can be butt-jointed together.

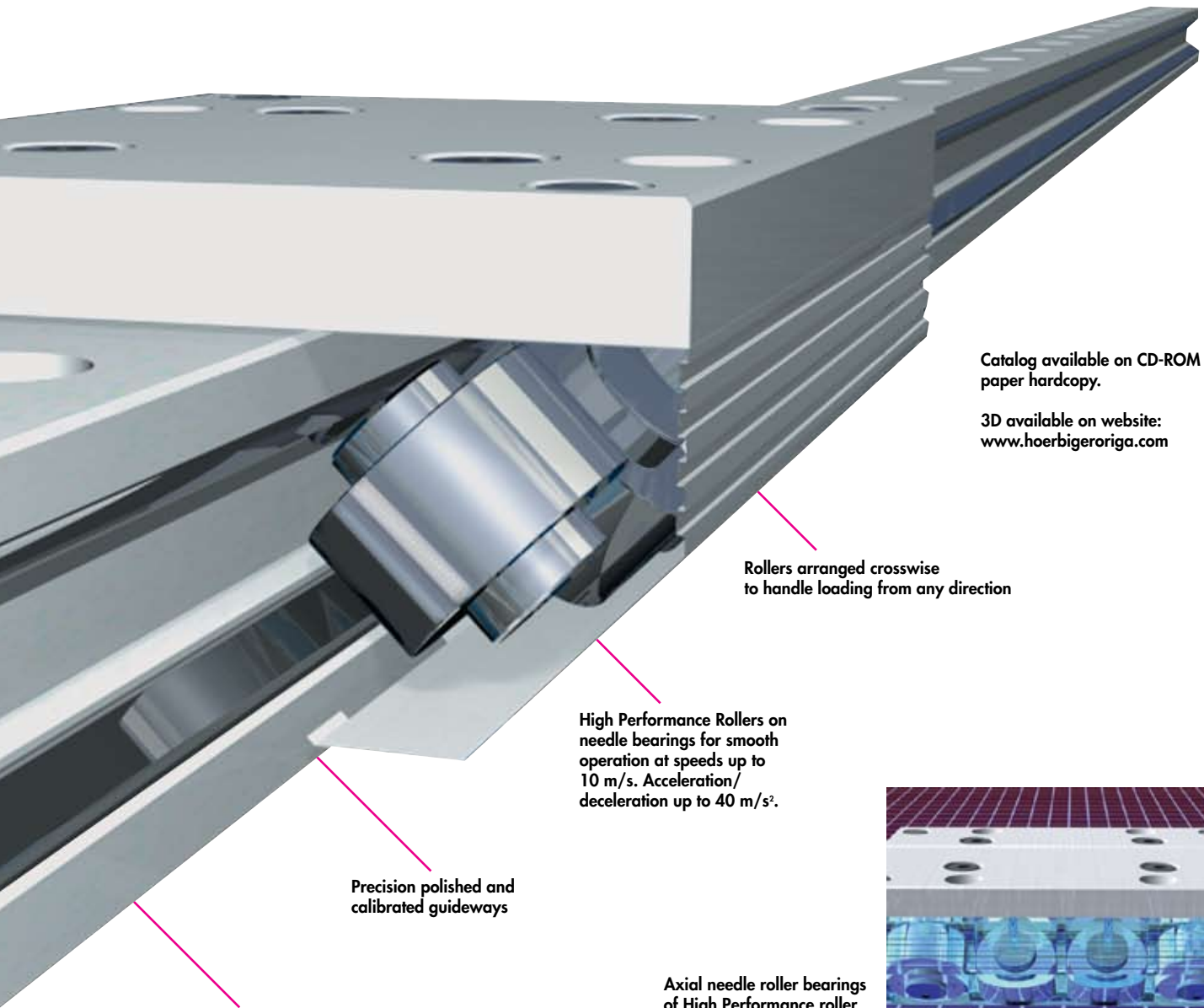

Catalog available on CD-ROM or paper hardcopy.

3D available on website: www.hoerbigeroriga.com

Rollers arranged crosswise to handle loading from any direction

High Performance Rollers on needle bearings for smooth operation at speeds up to 10 m/s. Acceleration/ deceleration up to 40 m/s².

Precision polished and calibrated guideways

Rail profiles and roller cassettes made of anodized aluminum

Axial needle roller bearings of High Performance roller cassette.

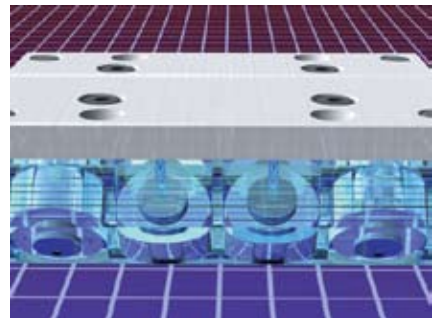

GDL Aluminum Roller Guides

GDL Product Line Overview

Characteristic	Unit	Description
Full profile wipers		Rollershoes and cassette are provided with snap-on full profile wipers. The snap-on full profile wipers are easily replaceable with available wipers kits. See page 8 for respective wiper kit order numbers.
Mounting		Rollershoes and cassettes use ISO screw quality 8.8 and DIN 433 washers. ISO screw quality 8.8 is recommended for mounting the rails also.
Loads		See load and moment rating tables on page 6 for respective load, moment and weight data per size and series.
Acceleration and Deceleration	m/s ² (ft/sec ²)	40 m/s ² maximum (131 ft/s ² maximum)
Guide installation		Possible in any position. See technical information on page 10 for specific instructions on installing various guide configurations.
Drag adjustment set screw		Cassettes can be adjusted at the factory or by the customer.
		Rollershoes can be set-up by the customer to incorporate the drag adjustment set screw feature. The drag adjustment set screw components are supplied with each pair of rollershoes.
Coefficient of friction		Variable, but .001 set at standard slide resistance adjustment.
Standard Lubrication		Lifetime lubrication with standard grease-packed roller bearings.
Speed	m/s (ft/s)	up to 10 m/s (or up to 33 ft/s)
Materials for High Performance or Standard versions		Rail: Aluminum alloy
		Guideways: Hardened high alloy spring steel
		Cassettes/rollershoes/top plates: Aluminum alloy
		Rollers: Bearing steel
Materials for Corrosion Resistant High Performance & Standard versions		Rail: Aluminum alloy
		Guideways: Stainless steel spring steel
		Cassettes/rollershoes/top plates: Aluminum alloy
		Rollers: Stainless steel bearing steel
Bearing types		Steel axial needle, Specials on request (ex: anti-magnetic, grease free, high dynamics) - consult factory
Operating temperature	C (F)	-10° to 80°C (+14 to 176°F) temperature range
Specials available		Custom length cassettes and rollershoes for 100 piece lots minimum.
		Keyed butt-jointed rail sections for continuous rail lengths over 4000mm.
		Solid continuous length rails between 4000.
		Offset or non-standard "L11" dimensions on opposite ends of cut rails.
		Integrated metal scraper with standard full profile wiper currently available.
		Rail underside blind mounting holes.

Descriptions of the various GDL Series available:

High Performance Series:

(Sizes FDC12HP-... thru FDC45HP-...)

The High Performance series is the basis for GDL's development, which is used in the majority of applications. High Performance guides consist of 8 axial needle roller bearings, running on precision polished and hardened alloy spring steel guideways. These guide bearings are grease packed and shielded, while offering the highest load and moment rating capacities within the GDL product line.

Standard Performance Series:

(Sizes FDC12SP-... thru FDC45SP-...)

The Standard Performance series is intended for minor loads and moments for particularly economical guidance solutions. Standard Performance guides consist of 8 radial ball roller bearings, running on precision polished and hardened alloy spring steel guideways. These guide bearings are grease packed and sealed, while offering the lowest load and moment ratings available within the GDL product line, with the exception of the Grease-Free and the Anti-Friction / Corrosion Resistant series. Standard Performance series is the second most commonly used GDL guides for various applications and also provides excellent running behavior.



GDL Aluminum Roller Guides

General facts pertaining to all series:

Snap-on full profile wipers: Rollershoes and cassettes can be provided with snap-on full profile wipers. The snap-on full profile wipers are easily replaceable with available wiper kits. See page 14 for respective wiper kit order numbers.

Cassette adjustment: Cassettes can be adjusted at the factory or by the customer.

Fasteners: Rollershoes and cassettes use ISO screw quality 8.8 and DIN 433 washers. ISO screw quality 8.8 is recommended for mounting the rails also. Special stainless steel fasteners can be requested as necessary.

Carrying Capacity: See load and moment rating tables on page 6 for your guide series of interest.

Guide mounting position: Optional.

Lengths: For longer than standard rail lengths, see keyed butt-jointed rail option on page 8.

Lubrication: GDL Aluminum Roller Guides are permanently lubricated with contained roller bearings grease.

See part numbering schemes on pages 14 and 15 to define your desired GDL guide features for ordering.

Drawing for cassette with double sided rail

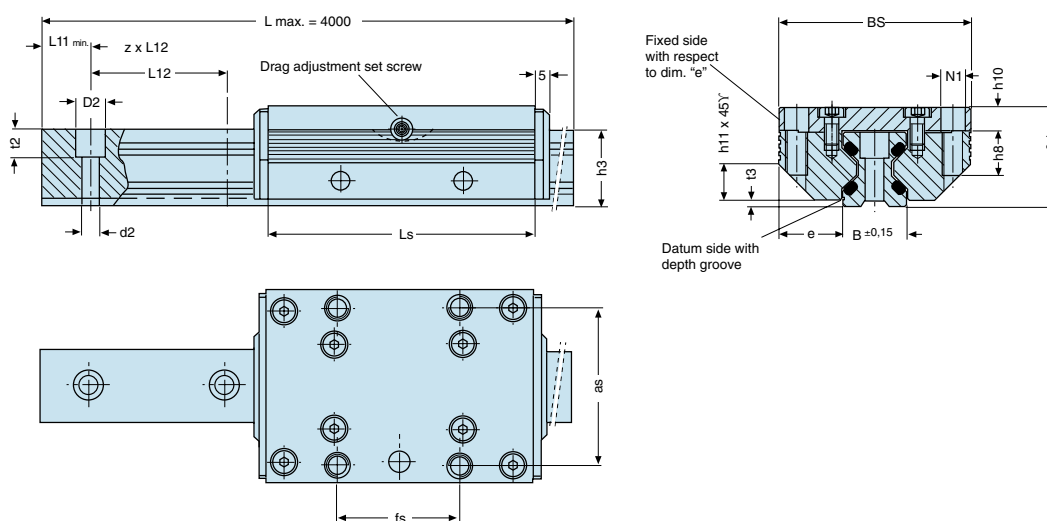

Dimensions for both standard FDC version guides

Size	Main dimensions											other dimensions																				
	Length Ls	Width BE	B	BS	B1	B2	Height h1	h3	h9	as	d2	D2	e	fs	h7	h8	h10	h11	L8	L9	L11	L12	t2	t3	N1	N2	N3	PF1	PF2	S1	S2	S3
12	64	12.00	12.0	37	24.4	11.9	15.0	14.7	19	30	3.4	6	12.50	25	6.0	8	4.0	6	29	57	10	40	5.5	1.4	M4	M3	M4	5.5	3.4	3.4	4.9	9.7
15	78	15.25	15.5	47	30.9	15.2	19.0	18.7	24	38	4.5	8	15.75	30	7.5	10	5.0	8	34	68	10	60	6.0	2.0	M5	M4	M6	7.0	4.4	4.9	5.9	12.4
20	92	20.00	21.0	63	40.9	20.4	23.0	22.6	30	53	5.5	10	21.00	40	8.0	12	7.0	11	42	80	10	60	7.0	2.0	M6	M5	M6	9.5	4.9	5.9	5.9	16.9
25	98	25.00	23.0	70	48.4	22.9	27.5	27.0	36	57	6.6	11	23.50	45	5.0	16	8.5	13	48	84	10	60	10.0	2.5	M8	M5	M8	12.0	6.4	7.4	8.9	19.4
35	135	35.00	32.0	100	68.9	32.9	37.5	37.0	48	82	9.0	15	34.00	62	7.5	20	10.5	20	67	117	12	80	11.5	3.5	M10	M6	M8	17.0	8.9	8.9	8.9	28.4
45	165	45.00	45.0	120	82.4	36.4	46.5	46.0	60	100	11.0	18	37.50	80	9.5	24	13.5	22	83	146	16	105	14.5	4.0	M12	M8	M8	22.0	9.9	9.9	8.9	30.9

Dimensions [mm]

Dimensions for both underside mounting hole FDC version guides (Ref. ordering instructions)

Size	Main dimensions											other dimensions																				
	Length Ls	Width BE	B	BS	B1	B2	Height h1	h3	h9	as	d2	D2	e	fs	h7	h8	h10	h11	L8	L9	L11	L12	t2	t3	N1	N2	N3	PF1	PF2	S1	S2	S3
12	64	12.00	12.0	37	24.4	11.9	15.0	14.7	19	30	3.4	6	12.50	29	6.0	8	4.0	6	29	57	10	40	5.5	1.4	M4	M3	M4	5.5	3.4	3.4	4.9	9.7
15	78	15.25	15.5	47	30.9	15.2	19.0	18.7	24	38	4.5	8	15.75	34	7.5	10	5.0	8	34	68	10	60	6.0	2.0	M5	M4	M6	7.0	4.4	4.9	5.9	12.4
20	92	20.00	21.0	63	40.9	20.4	23.0	22.6	30	53	5.5	10	21.00	40	8.0	12	7.0	11	42	80	10	60	7.0	2.0	M6	M5	M6	9.5	4.9	5.9	5.9	16.9
25	98	25.00	23.0	70	48.4	22.9	27.5	27.0	36	57	6.6	11	23.50	45	5.0	16	8.5	13	48	84	10	60	10.0	2.5	M8	M5	M8	12.0	6.4	7.4	8.9	19.4
35	135	35.00	32.0	100	68.9	32.9	37.5	37.0	48	82	9.0	15	34.00	62	7.5	20	10.5	20	67	117	12	80	11.5	3.5	M10	M6	M8	17.0	8.9	8.9	8.9	28.4
45	165	45.00	45.0	120	82.4	36.4	46.5	46.0	60	100	11.0	18	37.50	90	9.5	24	13.5	22	83	146	16	105	14.5	4.0	M12	M8	M8	22.0	9.9	9.9	8.9	30.9

Dimensions [mm]

The right to introduce technical modifications is reserved

Forces and Moments

Roll

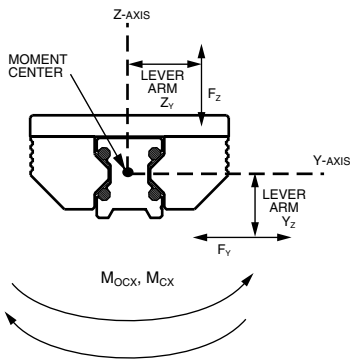

Pitch

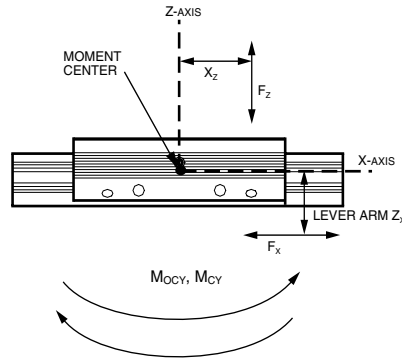

Yaw

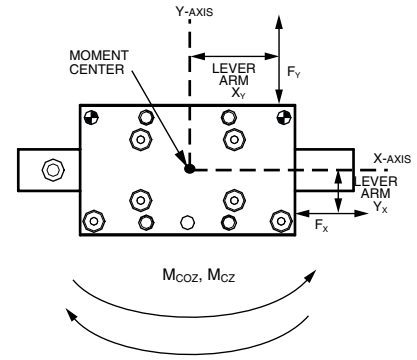

Load & Moment Rating Capacities (for cassettes on double sided rail)

Cassette Series	Dynamic Load Rating C (N)	Static Load Rating Co (N)	Static Moment Rating Capacities:			Dynamic Moment Rating Capacities:			Cassette Weight (kg)	Rail Weight (kg)
			Roll Mox (Nm)	Pitch Mocy (Nm)	Yaw Mocz (Nm)	Roll Mox (Nm)	Pitch Mocy (Nm)	Yaw Mocz (Nm)		
High Performance Series:										
FDC12HP-...	2800	3000	27	43	43	25	40	40	0.1	0.4
FDC15HP-...	4200	3400	37	58	58	45	72	72	0.3	0.8
FDC20HP-...	5400	5400	76	111	111	76	111	111	0.4	0.9
FDC25HP-...	9000	10100	158	222	222	142	198	198	0.6	1.8
FDC35HP-...	12500	18000	423	559	559	294	388	388	1.5	3.2
FDC45HP-...	21200	25900	827	983	983	678	806	806	2.9	5.5

The right to introduce technical modifications is reserved

GDL Aluminum Roller Guides

Special cassette types

High Performance cassettes with lock device

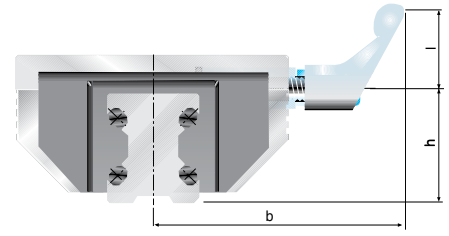
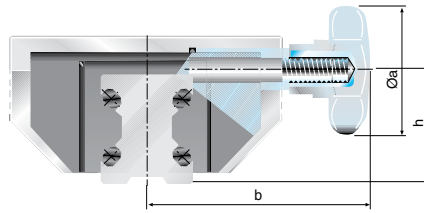

The locking cassette with star grip handle can be stopped at any desired location on the rail. The clamping device does not exert forces on the rail guideways.

The clamping device is used in fixtures which are movable manually, clamping and stop ledgers, feeding of tools and work pieces. Also available with L-ratchet handle.

Star Grip Handle Dimensions

Size	Ø a	b	h	Clamp force	Part numbers Star grip knob
12	N/A				
15	25	41	19.0	200	FDC15HP-00020000
20	25	49	23.0	250	FDC20HP-00020000
25	32	56	28.0	250	FDC25HP-00020000
35	50	83	38.5	350	FDC35HP-00020000
45	63	101	48.0	750	FDC45HP-00020000

Dimensions [mm], Force[N] with normal manual tightening.

L-Ratchet Handle Dimensions

Size	l	b	h	Clamp force	Part Numbers L-ratchet handle
12	N/A				
15	45	59.5	19.0	200	FDC15HP-00010000
20	45	67.5	23.0	250	FDC20HP-00010000
25	45	71	28.0	250	FDC25HP-00010000
35	63	96	38.5	350	FDC35HP-00010000
45	78	116	48.0	750	FDC45HP-00010000

End of Stroke Stop screws

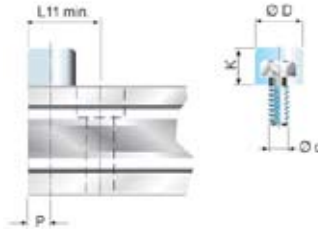
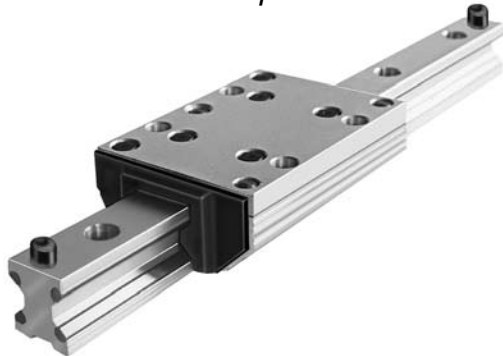

The stop screws are screwed into threads (option) on the guide rails. The end of stroke stopping energy is reduced by a rubber cap. With guide rails where the L11 is less than the standard minimum, we offset the mounting hole by half of its diameter.

Note: Customer must drill and tap the holes for the stop screws.

Size	d	D	K	L11 min.	P	Order number
12	M5	12	8	15.0	6.0	63504A
15	M5	12	8	16.0	6.0	63504A
20	M5	12	8	17.0	6.0	63504A
25	M6	15	10	20.5	7.5	63505A
35	M8	19	13	26.5	9.5	63506A
45	M10	24	16	33.0	12.0	63507A

Dimensions [mm]

GDL Accessories

Rail Mounting Screw Covers



Material: Wear resistant plastic, resistant to oil and aging.
Mounting: Put a plastic plate on top and pound in uniformly. Remove residual burrs with a soft brush or fingernail.

Note: Use respective order numbers for ordering separately or include in rail part number.

Size	Cylindrical screw DIN912	D	Order number
12	M3	6	87752A
15	M4	8	87753A
20	M5	10	87754A
25	M6	11	87755A
35	M8	15	87756A
45	M10	18	87757A

Dimensions [mm]

GDL Aluminum Roller Guides

Version with wipers

Integrated into an additional cover, a felt wiper is saturated with oil. Although dependent on the degree of contaminants, these wipers last for some 6000km, after which the felt wipers can

either be washed or replaced. For optimal cassette rolling performance, all holes in the guide rails should be filled with the plastic rail mounting screw covers (see page 7).

Order numbers for replacement wiper kits

FDC Series and size	Respective Order Number
12	84457B
15	84480B
20	84481B
25	84482B
35	84483B
45	84484B

*wiper kits are sold in pairs

NOTE: Use respective order numbers for ordering separately as replacements, or specify in cassette part number. See cassette part numbering on pages 14 and 15.

GDL's Keyed Butt-Jointed Rail Option

GUIDELINE rails can be precisely fastened together using a factory offered keyed butt-joint option for continuous rail lengths, as shown in Figures 1 & 2.

Two rail sections are clamped together with mating round bar stock pieces that seat tangent to both rail section guideways on each side of the rail. While the rail sections are clamped together, a keyway slot is machined in the top and bottom sides of the rail, across the butt-joint. Screw holes are then drilled through the rail inside the keyway slot, so the opposing keyways can be drawn together tightly with screws. The round bar stock clamp is then removed, providing a rigid and well aligned keyed butt-joint.

The keyed butt-joint option provides optimum alignment of all guideways from one rail section to the next. This allows for optimum "smooth" guidance of the cassette bearings, while crossing rail butt-joints.

The keyed butt-jointed rail option is currently available in the FDR version 25, 35, & 45 mm rail sizes. For a keyed butt-joint on rail sizes 25, 35 or 45 mm, specify P/N:# **GDL-BJK**

Consult factory for other size possibilities.

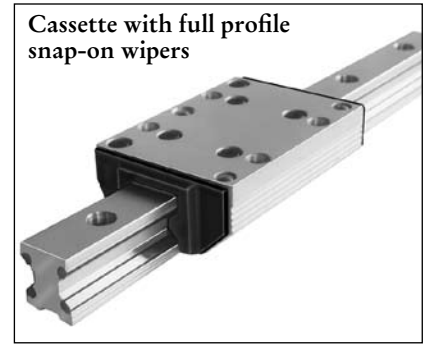

Full profile snap-on wiper

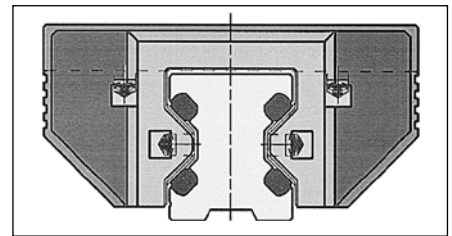

GDL Coupled with structural aluminum extrusion material and OSP-E actuator

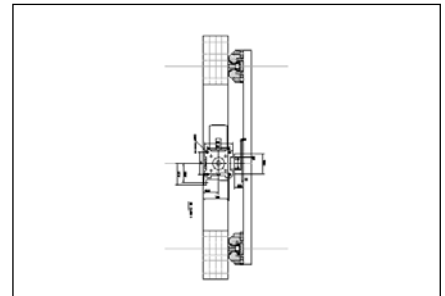

Figure 3

GDL linear guides couple well with various structural aluminum extrusions and Parker Origa OSP-P and OSP-E actuators. Mounting can be easily accomplished using standard fasteners and mounting brackets. See figure 3 above.



Figure 1



Figure 2



Units Conversion Tables

Force conversions:

Multiply	By conversion factor	Result
pound-force	4.448	Newton
Newton	0.225	pound-force
kilogram-force	9.807	Newton
Newton	0.102	kilogram-force

Acceleration conversions:

Multiply	By conversion factor	Result
feet/section ²	0.305	meter/second ²
meter/second ²	3.281	feet/second ²
inch/second ²	0.025	meter/second ²
meter/second ²	39.370	inch/second ²

Mass conversions:

Multiply	By conversion factor	Result
ounce	28.349	gram
gram	0.035	ounce
kilogram	35.279	ounce
gram	0.001	kilogram
pound	0.453	kilogram
kilogram	2.205	pound

Bending moment or torque conversions:

Multiply	By conversion factor	Result
pound-foot	1.356	Newton-meter
Newton-meter	0.737	pound-foot
Newton-meter	0.102	kilogram-meter
Kilogram-meter	9.807	Newton-meter

Velocity conversions:

Multiply	By conversion factor	Result
mile/hour	1.609	kilometer/hour
kilometer/hour	0.621	mile/hour
feet/second	0.305	meter/second
meter/second	3.281	feet/second
inch/minute	0.025	meter/minute
meter/minute	39.370	inch/minute

Length conversions:

Multiply	By conversion factor	Result
inch	25.4	millimeter
millimeter	0.039	inch
inch	0.025	meter
meter	39.370	inch
foot	0.305	meter
meter	3.281	foot

GDL Aluminum Roller Guides

Technical information

1. Features of the guide system

Aluminum roller guides consist of a double sided rail and a roller cassette or two single sided rails and two roller shoes. Aluminum roller guide rails and cassettes are made of aluminum alloy. The rollers are very smooth running on precision polished guideways made of high alloy spring steel. The special cross pattern orientation of the running rollers provides high load and moment capacity in all directions.

Their special features are: light weight, small dimensions, and high speed of displacement. Aluminum roller guides are economical and universal handling components, which are mostly or all corrosion-resistant and available at a favorable price.

2. Size of the guide system

To select the right guide size, first the moments and forces acting on the bearing have to be determined.

Recommended safety factors (with ISO screws quality 8.8):

Thrust load	$S > 1.3$
Tensile load	$S > 4.0$
Moment load	$S > 6.0$

3. Material

The basic body of GDL aluminum roller guides is made of aluminum alloy. The guideways consist of hardened, high alloy spring steel or of stainless steel. By using basic bodies of aluminum, the moved masses are reduced which allows light-weight construction requiring lower moving forces and reduced energy consumption. Still the integrated GDL system sustains high load and moment ratings.

4. Operating temperature

GDL linear guides can be operated within a temperature range from -10°C up to $+80^{\circ}\text{C}$. For other temperatures, please consult factory.

5. Screwed connections

GDL linear guides are fixed to the mating structure by the mounting holes in the rails and the cassettes. ISO screw quality 8.8 should be used with DIN 433 washers.

To secure the screwed connections, we recommend that suitable locking means be utilized as necessary.

Mounting screw torque specifications:

	Quality 8.8 [Nm]
M3	1.1
M4	2.5
M5	5.0
M6	8.5
M8	21.0
M10	41.0
M12	71.0

6. Wipers

The guideways of aluminum roller guides are equipped with wipers to protect against coarse environmental contamination.

7. Slide resistance / adjustment

Follow the steps on how to adjust GDL cassettes to the rail.

The new GDL catalog has many changes due to an expanded product line. The change to feature descriptive part numbering was done to accommodate all current and future offerings of the GDL product. The goal is to have standard features and options available, for a perfect fit into your application.

Included in the chart below are hex sizes, drag resistance and torque ratings for adjusting the cassette.

	GDL CHART					
	FDC 12	FDC 15	FDC 20	FDC 25	FDC 35	FDC 45
Top plate hex (mm)	2	3	4	4	5	6
Top plate torque (in lbs)	n/a	22.1	44.3	44.3	75.2	186
Adjustment hex (mm)	1	3	3	4	4	4
Drag resistance (oz) HP, HC, GF, VA	1.8- 7.9	3.6- 10.8	5.4- 16.2	7.2- 21.6	10.8- 32.4	12.6- 37.7
Drag resistance (oz) SP & SC	.7- 1.8	1.8- 3.6	3.6- 7.2	5.4- 10.8	7.2- 14.4	9- 18
Drag resistance (oz) HD	n/a	n/a	n/a	9- 18	14.4 25	18- 28.7

7.1 GDL adjustment procedure

Do not measure sliding resistance with wipers on.

1) Lay the rail out on the flat surface with the **datum** line facing away from you. Anchor the rail to keep it from shifting when sliding resistance is applied to the cassette.

The datum line is a reference groove on one side of the rail.

2) Set the roller cassette on the rail with the adjustment screw facing towards you, while the datum line on the rail is away from you. Do not install the wipers on the cassette yet.

Do not install the wipers yet.

3) Make sure the four bolts on the adjustable side of the cassette are slightly loose and the bolts on the fixed side are tight before adjusting the drag screw.

One side of the cassette is fixed and the other side is floating.

4) The drag hex screw is located on one side of the cassette. Adjust the screw in for more drag and out for less. Do not try to adjust cassette with top plates bolts tight.

See the chart for drag adjustment hex screw size.

5) Adjust the drag on the cassette by sliding as it slides down the rail. Feel for an even amount of resistance as you turn the hex screw in and out.

6) Tighten down the top plate bolts to the proper torque specification. The tightening of the top plate bolts will add some resistance. If necessary, the adjustment procedure can be repeated for better sliding resistance for your application.

See the chart for top plate hex size and torque rating.

7) If the adjustment is done without a scale, it should move evenly. Some examples of improper adjustment are: If the cassette "hops", it is too tight. If it is too loose, the top plate of the cassette will have play. Try to be in the middle.

8) To check your settings use a pull or push style scale. Slide the cassette down the entire rail at an even speed, measuring the drag resistance. Your highest drag rating should be referenced when looking at the chart.

See the chart for drag resistance ratings for the size and type of cassette.

9) Install the clip on wipers. The wipers will add between 1-3 ounces of resistance. The wipers do not add any additional roller preload to the rail.

The clip on wipers can be installed at this time.

7.2 Double sided rail and cassette

Aluminum roller guides are adjusted in such a way that the required stiffness under load is obtained. If self adjustment is preferred, we recommend that you measure the slide resistance as shown below. Before doing so, the mating structure should be checked for dimensional accuracy and flatness.

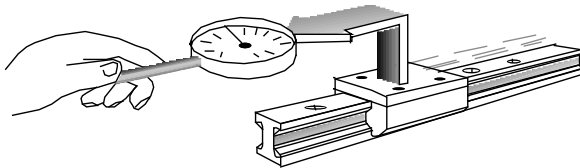

The cassettes which are mounted on the rails are adjusted clearance-free, without play. This adjusting method is required at the point on the rail where the cassette travels with the least slide resistance. Adjustment is completed in the non-loaded condition. The tolerances below refer to this condition.

Series	Slide resistance adjustment tolerance [N]														
	FDC_HP, FDC_HC, FDC_AM, FDC_GF, FDC_VA						FDC_SP, FDC_SC						FDC_HD		
Size	12	15	20	25	35	45	12	15	20	25	35	45	25	35	45
Adjust. value	0.5	1.0	1.5	2.0	3.0	3.5	0.2	0.5	1.0	1.5	2.0	2.5	2.5	4.0	5.0
Max. value	2.0	3.0	4.5	6.0	9.0	10.5	0.5	1.0	2.0	3.0	4.0	5.0	5.0	7.0	8.0

All values are without wipers

Tolerances in the guide system may cause slight variations in the slide resistance, when the adjusted cassette is moved along the guide rail.

7.3 Double sided rail and roller cassette

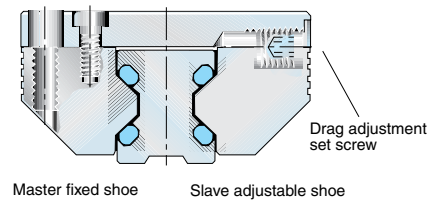

To change the clearance setting, first the slave adjustable shoe screws on the cassette top plate are slightly loosened. Afterwards, the drag adjustment set screw is turned to increase or decrease slide resistance of the cassette. Turning the drag adjustment set screw effects a displacement of the roller shoe in relation to the cassette top plate.

After re-tightening of the cassette top plate, the slide resistance can be checked. This procedure can be repeated until the desired slide resistance is achieved.

7.4 Rails and rollershoes

When installing, it is important to distinguish between the master fixed side and the slave adjustable side rollershoe and rail. The rail on the master fixed side is aligned to the mating structure and fastened securely by all screws.

The rail on the slave adjustable side should be lightly tightened and movable with light force during initial alignment of parallel rails. Gauge blocks should be used between the parallel rails, by locating off the aligned and mounted master rail, in order to align the slave rail parallel to the master rail. Slave rail mounting bolts should be tightened as the slave rail is aligned at each bolt position. See paragraph 11.3 for further instructions on mounting parallel single sided rails.

7.5 Centering groove on the master fixed shoe and custom top plate

Each pair of rollershoes are provided with centering grooves for optimum alignment to their mating top plate during mounting. One rollershoe should be designated as the master fixed rollershoe, even though both are designed with a centering groove on their top surface. The other shoe will serve as the slave adjustable side rollershoe. The mating customized top plate should be machined with a centering shoulder according to the following data.

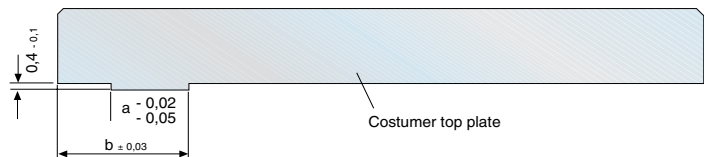

Size	a	b
12	4,5	9,6
15	5,0	12,6
20	7,5	16,1
25	10,5	17,6
35	12,5	26,1

7.6 Adjusting cassette built with rollershoes and custom top plate

The centering shoulder on the top plate should be assembled with its respective fixed rollershoe centering groove and securely torqued to recommended specification. See cassette screw torque specifications under step 5, on page 10.

Assemble the adjustable rollershoe to the top plate also, parallel to the fixed rollershoe on the same side of the top plate. Its fasteners should be lightly tightened so that the adjustable rollershoe can be moved with light finger pressure.

As assembled cassette can then be slid onto parallel rails, while keeping the fixed rollershoe on the master fixed rail side. The incorporated drag adjustment set screw can then be turned clockwise to remove cassette play, or counter clockwise to reduce slide resistance while maintaining zero play.

Once the desired slide resistance is achieved with no cassette play, the adjustable rollershoe fasteners can also be torqued to specification.

8. Running accuracy

The running accuracy is measured from the top plate surface of the cassette, to the ideal straight line of travel. Running accuracy of the cassette to the rail is +/- .03mm (.0012") per meter, granted no greater than (.0024") straightness deviation per meter is maintained when mounting the rail.

9. Contact and support surfaces

The contact and support surfaces have a substantial influence on functioning and precision of linear guides. Depending on the functional requirements of the system, the mating structure has to be machined with the corresponding degree of precision. Machining errors on the mating structure will otherwise add to the running error of the guide system. In order to assure troublefree functioning, we recommend that a max. straightness deviation of $\leq 0.1 \text{ mm}$ (.0039") per running meter be maintained when mounting the rail.

10. Design hints

10.1 Parallel double sided rails and cassettes

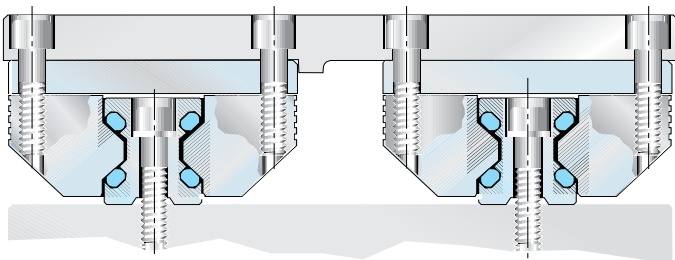

The master fixed rail should always be established straight and true first, within the maximum straightness deviation specified in paragraph 9. With parallel rail arrangements, both rails should be mounted on the same mounting surface elevation and treated with equal surface preparation and tolerancing practices. Precise alignment in terms of spacing, parallelism and height is very important.

When coupled parallel to a driving actuator system, the adjustable side of the cassette should be placed on the side closest to the driving actuator. This will minimize driving actuator torque transferred to the adjustable side of the cassette.

11. Guide mounting instructions

The useable load capacity is influenced by the connection between the guide elements and the mating structure. For this reason, a flat, straight and solid secure mounting surface should be provided. Adequate support of qualified loads and moments can then be achieved, along with desired running accuracy.

11.1 Mounting double sided rails and cassette

Depending on the load situation, certain double sided rails should either be screwed or screwed and dowelled, and respectively put into grooves or against a shoulder.

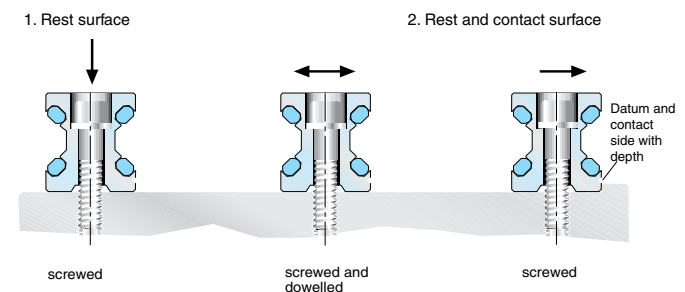

The rails can be secured best against shoulders and are screwed or screwed and dowelled to the mating structure. After final adjustment of rail straightness and parallelism, the rail mounting screws are tightened starting in the middle of the rail length. Rail mounting bolts should be torqued to specification by alternating between each bolt. The installer should start with the bolt in the center of the rail length and proceed by alternating between each bolt left of center and each bolt right of center, while working towards both ends of the rail.

Afterwards, the cassette should be moved back and forth along the total stroke distance of the rail. If the cassette travels smoothly, the mounting process can proceed or be completed.

11.2 Mounting parallel double sided rails and cassettes

With parallel double sided rail arrangements, we recommend that the master fixed rail side and slave adjustment rail sides of the guide system be identified. This allows optimum tolerances in parallelism to be achieved best by adjusting the slave adjustable rail, parallel to the master rail. The master fixed rail side should be mounted first to achieve the initial line of straight travel.

The example below displays a convenient method for adjusting the slave adjustable rail parallel to the fixed master rail. Once the cassette travel is smooth, without play, one can proceed with rail mounting.

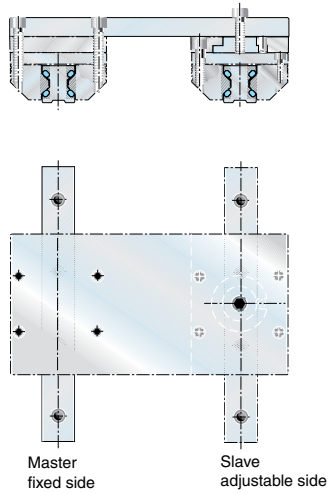

Note that the top plate spanning across the cassettes on opposite rails is completely bolted down to the cassette on the master fixed side only. The top plate end over the slave adjustable side is only bolted in one location, in the center of the slave adjustment side cassette. With one bolt holding the top plate to the slave adjustment side cassette, this cassette can pivot while the slave adjustable rail self-aligns parallel to the fixed master rail side. The floating top plate setup is stroked along the entire rail length, to establish the parallelism between the two rails.

Calibrated guage blocks can also be used to establish equal integrity in rail parallelism. The installer should seat and temporarily clamp short pieces of precision ground round stock, tangent to the two guideways on the inside of each rail.

Rail Size	Precision round stock sizes Ø mm
12	11
15	11
20	14
25	16
35	27
45	35

The calibrated guage blocks can then be used, to locate off the precision round stock on the master fixed rail, in order to set the slave adjustable rail parallel. The guage blocks are then locating the same way that the floating top plate is, by referencing both the master and slave rail guideway surfaces to establish parallelism.

Once the slave adjustable rail has been self-aligned, its bolts should also be torqued to specification in the order mentioned in paragraph 11.1. The top spanning across both cassettes on opposite rails, can then be securely fastened using all cassette mounting bolt holes.

12. Keyed butt-jointing of rail sections

12.1 Rail hole spacing

Butt-jointed rails over L = 4000 mm are sectioned together according to the GDL standard. See "GDL's Keyed Butt-Jointed Rail Option" on page 8. Butt-jointed rails sections are cut so that the standard rail mounting hole spacing is maintained across all butt-joints.

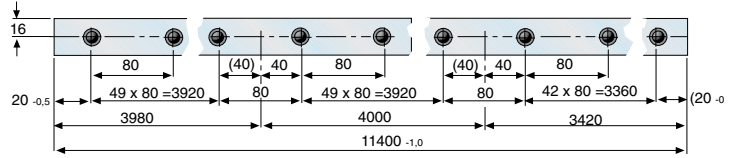

Keyed butt-jointed rails are usually shipped completely assembled, but sometimes must be shipped partially assembled, due to shipping length limitations and shipping care. Partially assembled butt-jointed rails are supplied with a butt-jointing clamping fixture and the keyways and screws for fastening rail section together.

12.2 Mounting of butt-jointed rails

Clean mounting surfaces, then place rail sections loose on the guide path, one behind the other. Lay the rails in their correct sequence of the system design (i.e.: 1, 2, 3, 4...etc.). The orientation of the depth groove on the lower surface of the rail should always be on the same side for all rail sections being butt-jointed.

Any non-assembled rail sections should be aligned with the factory supplied butt-joint clamping fixture as displayed below.



See explanation of "GDL's Keyed Butt-Jointed Rail Option" on page 8.

Once all rail sections are assembled, the complete guide path can be aligned and fastened. Alignment and fastening should be conducted according to the applicable guide arrangement and steps previously described in this technical information section.

Ordering Instructions

GDL Rail Part Numbering

1	2	3	4	5	6	7	8	
Series		Rail	Size	Guideway Material		Coatings	Mounting Holes	
F	D	Double Sided Rail Guide* (Standard)	R	1	2*	H High Performance Alloy Steel* (Standard)	0 Anodized Aluminum* (Standard)	0 Topside Thru Hole* (Standard)
				1	5*	S Stainless Steel*	Z Custom (Consult Factory)	1 Underside Blind Thread
				2	0*			Z Custom (Consult Factory)
				2	5*			
				3	5*			
				4	5*			

*STOCKED ITEM

GDL Cassette Part Numbering

1	2	3	4	5	6	7	8	9	10
Series		Cassette	Size	Bearing Options		-	Grease	Lubrication Options	
F	D	Double Sided Rail Cassette* (Standard)	C	1	2*	H P Axial Needle - High Performance - Alloy Steel* (Standard)	0	High Performance* (Standard)	0 None* (Standard)
				1	5*	S P Single Row Radial Ball - Standard Performance - Alloy Steel*	Z	Custom (Consult Factory)	Z Custom (Consult Factory)**
				2	0*				
				2	5*				
				3	5*				
				4	5*				
						Z Z Factory)**(Consult Factory)**			

*STOCKED ITEM

**Minimum Order Quantity Required

Note: The FE Series is not part of our standard offering any longer. Please consult factory for technical support if there is a specific application.

9	10		11		12		13	14	15	16	17	18
"L11" Dimension			Long Rail Joining Option		Screw Covers		- Length (mm)					
0	0	Equal On Both Sides* (Standard)	0	None* (Standard)	0	None* (Standard)	-	0	0	0	0	0
?	?	Actual Dimension (mm)**	1	Keyed Butt Joint (Size 25-45 only)	1	Yes*	Maximum length is 4 meters on size 12					
		**As Measured From Left Side While Viewing The Depth Groove Line.	2	Unkeyed Butt Joint	Note: Quantity Supplied To Cover All Rail Holes.							

11		12		13		14		15		16	
Coatings		Locking Mechanism		Mounting Holes		Wiper Options		Cassette Length		Adjustment	
0	Anodized and Standard Hardware* (Standard)	0	None* (Standard)	0	Topside Threaded Thru* (Standard)	0	With Felt Wipers* (Standard)	0	Normal Length* (Standard)	0	None* (Standard)
1	Anodized and Stainless Steel Hardware*	1	"L" Ratchet Handle*	1	Underside Hole Thru (Unthreaded)	1	Without*	Z	Custom (Consult Factory)**	1	Adjusted to Specific Rail*
Z	Custom (Consult Factory)	2	"Star Grip Handle"	2	Underside Hole Thru (Threaded)	2	With Felt Wipers and Scrapers*				

Note: Locking Mechanism Only
Available on FD Series Size
15 thru 45 with Axial Needle
Bearing - High Performance -
Alloy Steel.

GDL Application Sheet

Distributor: _____ End-User: _____

Salesperson: _____

Phone: _____ Fax: _____ e-mail: _____

Other Information: _____

Roll

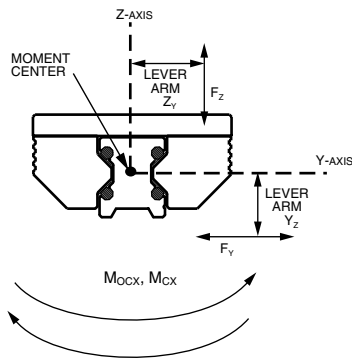

Roll load _____
 X - Distance _____
 Y - Distance _____
 Z - Distance _____

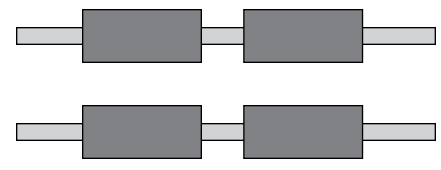

Length of rails _____
 Distance between rails _____
 Distance between cassettes on each rail _____

Pitch

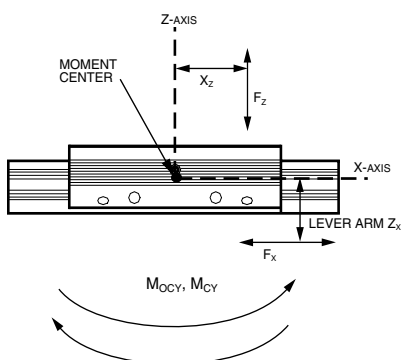

Pitch load _____
 X - Distance _____
 Y - Distance _____
 Z - Distance _____

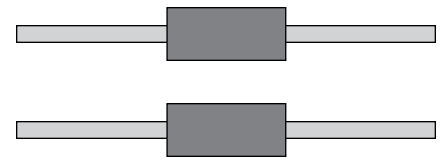

Technical Data:
 Stroke _____
 Horizontal _____
 Vertical _____
 Velocity / Speed _____
 Acceleration _____
 Load / Mass _____
 Load Distances _____
 Lifetime Desired _____

Yaw

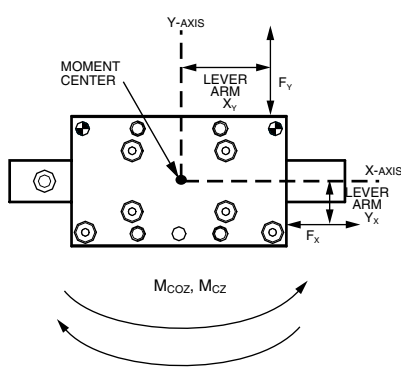

Yaw load _____
 X - Distance _____
 Y - Distance _____
 Z - Distance _____

Environment:
 (Dirt, Humidity...)

Fax back to Technical Assistance Fax 630-871-1515 Phone 630-871-8300



Sketch:

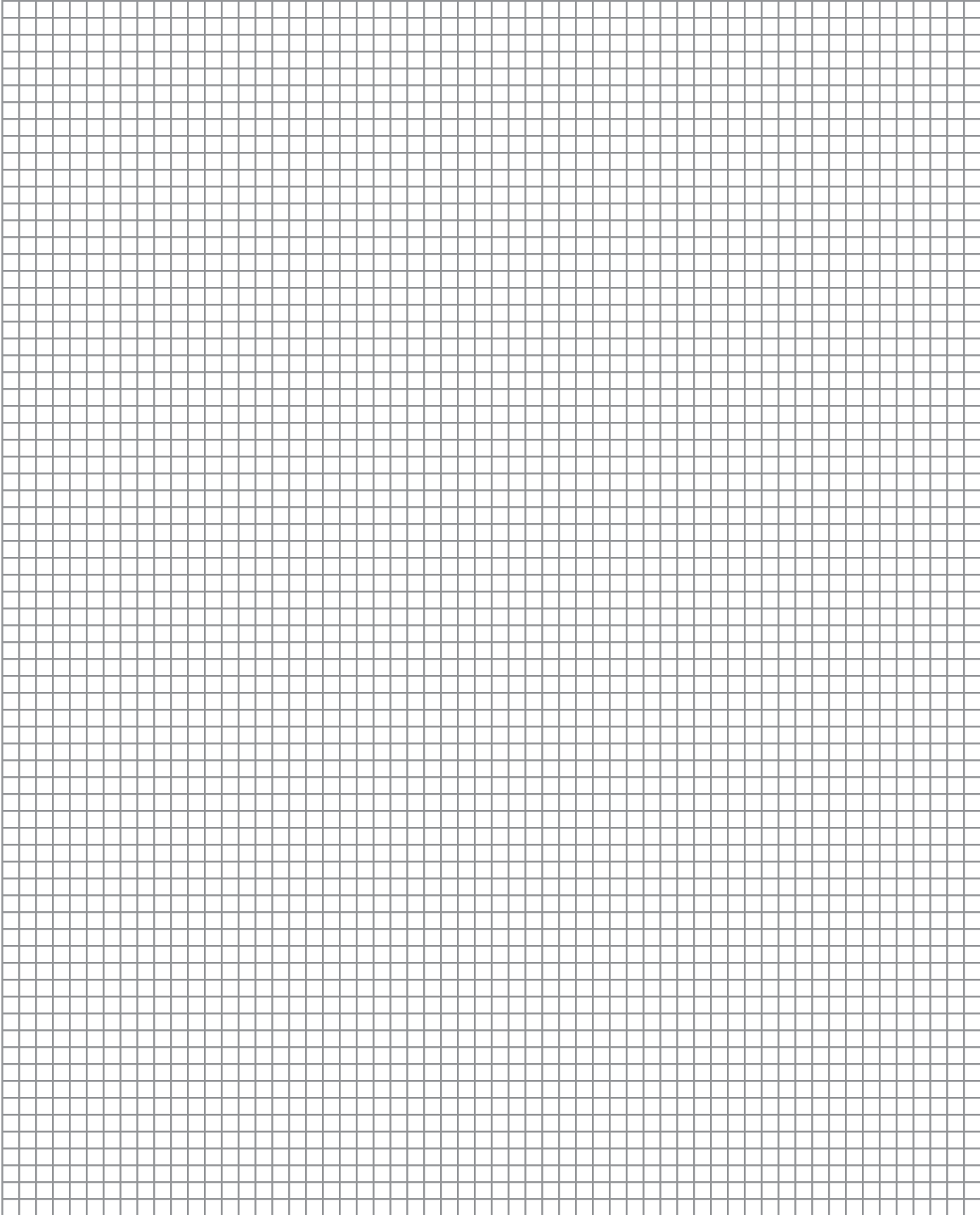



Advice, service and sales
... worldwide and round
the clock

LINEAR DRIVES - WHETHER PNEUMATIC OR ELECTRIC - FROM ONE SOURCE

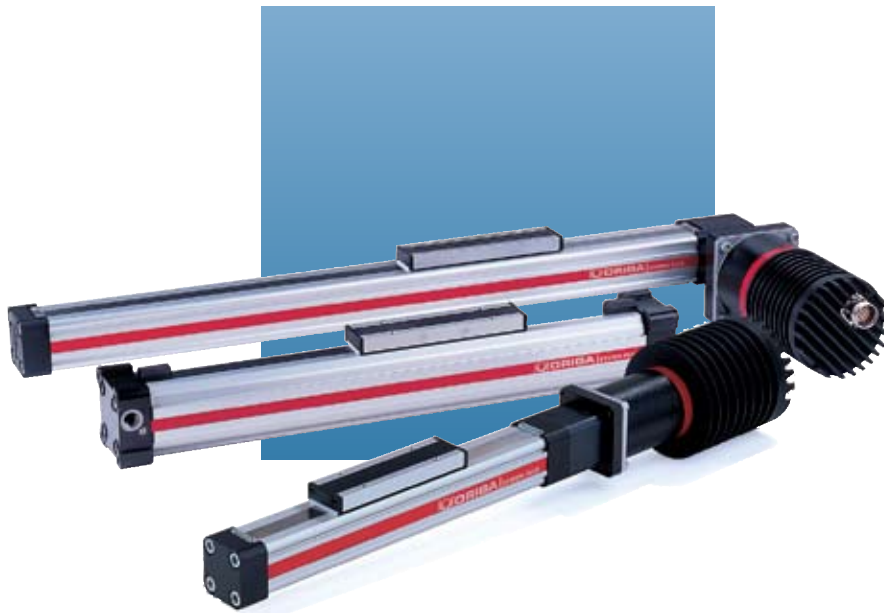

Parker ORIGA CORPORATION • 100 West Lake Drive, Glendale Heights, IL 60139 • tel (630) 871-8300 • fax (630) 871-1515
Internet: <http://www.parkeroriga.com>
A3P098USA-05/08