

PATENT NUMBERS
5713755
5961339

CLE-1XX-XX-X-DV-XX

- No OF POSITIONS
-04 THRU -90
(PER ROW)
- LEAD STYLE
-01
(USE C-80-01-X)
- AT** PLATING SPECIFICATION
-F: 3µ" FLASH SELECTIVE GOLD ON ENTIRE CONTACT
-G: 10µ" LIGHT GOLD ON ENTIRE CONTACT
- OPTION
-P: PICK & PLACE PAD (SEE FIG 2, SHT 2) **AT**
(AVAILABLE ON POSITIONS -08 THRU -90 ONLY))
(USE LMP-10)
-TR: TAPE & REEL PACKAGING
-A: ALIGNMENT PIN (SEE FIG 3 & 4, SHT 2)
(MOLDED TO POSITION OR STAKED)
(SAMTEC DISCRETION WHICH -A PIN IS USED)
(STAKE 7 POSITIONS MIN)
(MOLD 4 POSITION MIN)
-K: POLYIMIDE FILM PAD
(AVAILABLE ON POS. 8 THRU 90 ONLY)
(.005 [.13] THICKNESS WITH SILICONE ADHESIVE) (SEE FIG 5, SHT 2)
(USE K-500-300)
- ROW SPECIFICATION
-D: DOUBLE ROW - VERTICAL
(USE CLE-90-D)

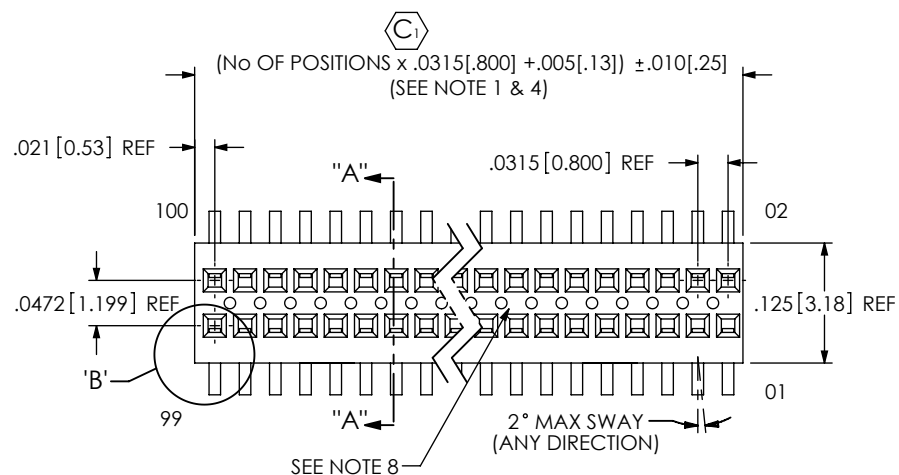
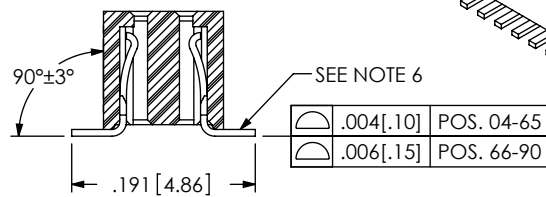
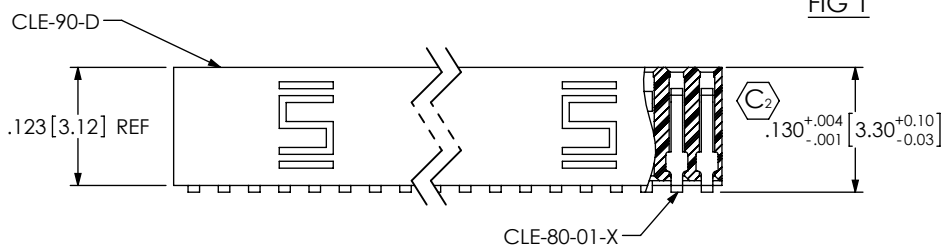
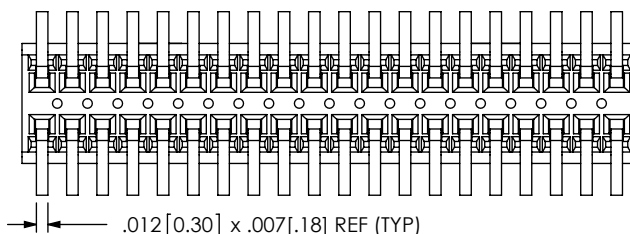

FIG 1



SECTION "A"-"A"



END WALLS TO BE SYMMETRICAL ±.0050

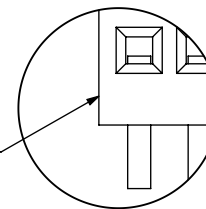

DETAIL 'B'
SCALE TO: 1

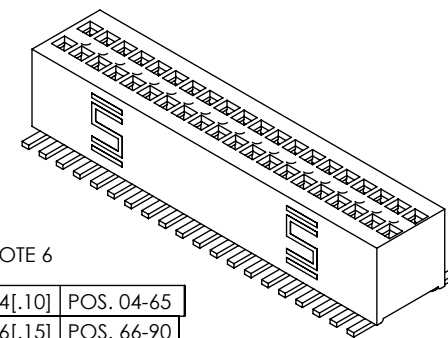

TUBE	PLUG
PT-1-24-01-62	TP-12

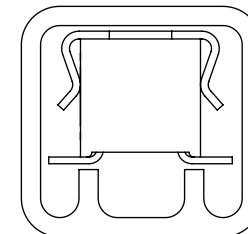

TUBE ALL POSITIONS

NOTES:

1. C REPRESENTS A CRITICAL DIMENSION.
2. NOTE DELETED.
3. MINIMUM PUSHOUT FORCE: .5 LB.
4. WILL LOSE TWO POSITIONS FOR EVERY CUT MADE. MAXIMUM CUT FLASH TO BE .010 [.25] WITH NO FLASH IN HOLES OR EXTENDING BELOW LEADS.
5. NOTE DELETED.
6. BURR ALLOWANCE: .003 [.08] MAX
7. ENDWALL AFTER CUTTING: .0115±.0025 [.292±.064]
8. VOIDS ON TOP SURFACE TO BE LOCATED AT VENDOR DISCRETION TO CONTROL PART WARPAGE.

UNLESS OTHERWISE SPECIFIED, DIMENSIONS ARE IN INCHES.
TOLERANCES ARE:
DECIMALS ANGLES
.XX: ±.01 [.3] 2°
.XXX: ±.005 [.13]
.XXXX: ±.0020 [.051]

PROPRIETARY NOTE
THIS DOCUMENT CONTAINS INFORMATION CONFIDENTIAL AND PROPRIETARY TO SAMTEC, INC. AND SHALL NOT BE REPRODUCED OR TRANSFERRED TO OTHER DOCUMENTS OR DISCLOSED TO OTHERS OR USED FOR ANY PURPOSE OTHER THAN THAT WHICH IT WAS OBTAINED WITHOUT THE EXPRESSED WRITTEN CONSENT OF SAMTEC, INC.

MATERIAL: DO NOT SCALE DRAWING SHEET SCALE: 5:1
INSULATOR: LCP, UL 94 VO, COLOR: BLACK
CONTACT: BeCu 190 ALLOY [TM04]
THICKNESS: .007 [.18] REF

DESCRIPTION:
.8MM x 1.2MM C.L. SOCKET STRIP ASSEMBLY
DWG. NO. CLE-1XX-XX-X-DV-XX

samtec

520 PARK EAST BLVD., NEW ALBANY, IN 47150
PHONE: 812-944-6733 FAX: 812-948-5047
e-Mail: info@SAMTEC.com code 55322

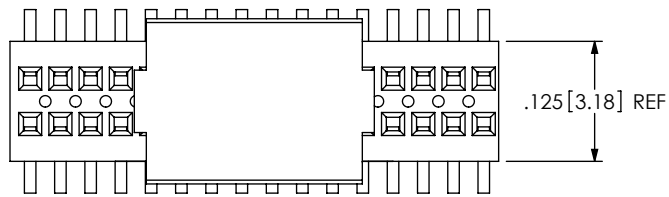
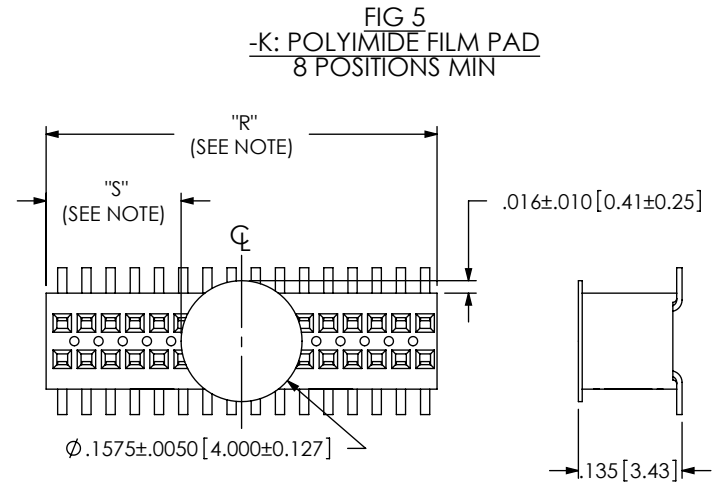
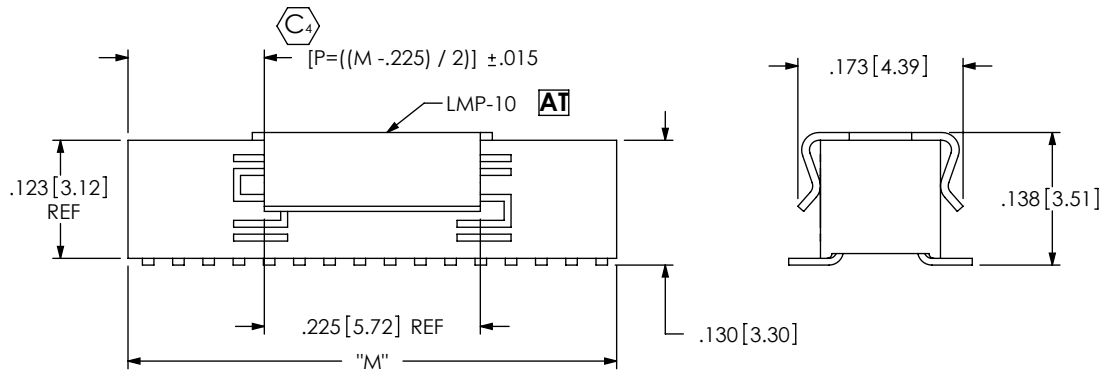
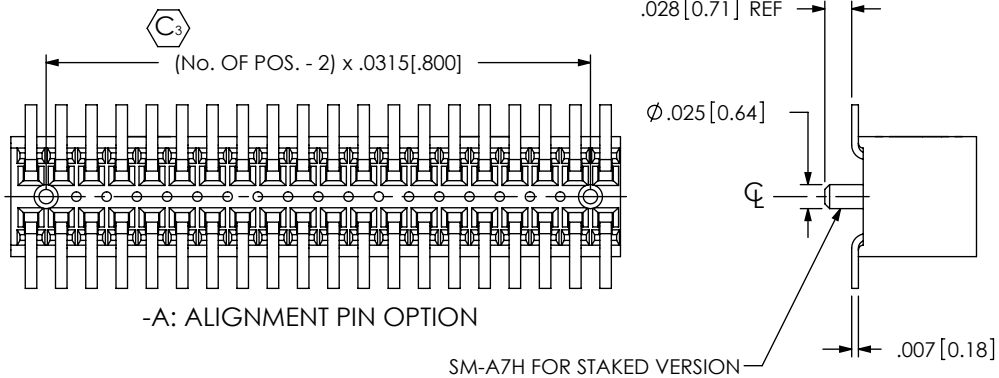

FIG 2
-P OPTION
8 POSITIONS MIN



NOTE: "R" = USED MEASURED DIMENSION (REF)
"S" = [("R" - .1575 [4.00]) / 2] ± .020 [.51]



-A: ALIGNMENT PIN OPTION

SM-A7H FOR STAKED VERSION

FIG 3
-A STAKED OPTION
7 POSITIONS MIN

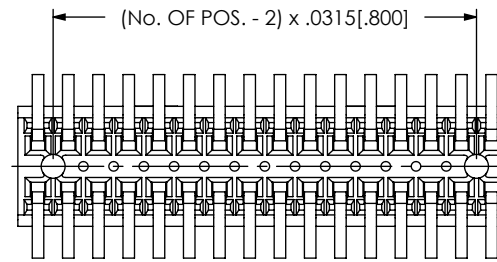
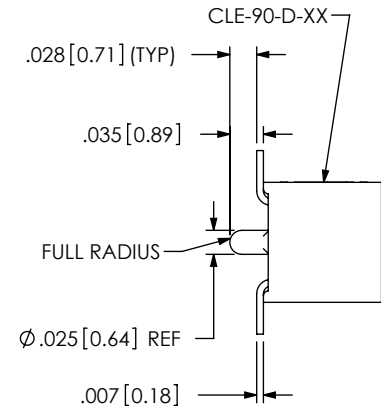

FIG 4
-A OPTION (MOLDED)
4 POSITIONS MIN



PROPRIETARY NOTE
THIS DOCUMENT CONTAINS INFORMATION
CONFIDENTIAL AND PROPRIETARY TO
SAMTEC, INC. AND SHALL NOT BE REPRODUCED
OR TRANSFERRED TO OTHER DOCUMENTS OR
DISCLOSED TO OTHERS OR USED FOR ANY
PURPOSE OTHER THAN THAT WHICH IT WAS
OBTAINED WITHOUT THE EXPRESSED WRITTEN
CONSENT OF SAMTEC, INC.

DO NOT SCALE DRAWING

SHEET SCALE: 5:1

samtec

520 PARK EAST BLVD. NEW ALBANY, IN 47150
PHONE: 812-944-6733 FAX: 812-948-5047
e-Mail info@SAMTEC.com code 55322

DESCRIPTION:
.8MM x 1.2MM C.L. SOCKET STRIP ASSEMBLY

DWG. NO.
CLE-1XX-XX-X-DV-XX

BY: PURVIS 10/23/95 SHEET 2 OF 2