

**G**lenair®



# VG95328 Qualified Bayonet-Lock Connectors

*High-Density MIL-C-26482 Type Connectors—VG95328  
Qualified for Rugged Military and Industrial Applications*

United States ■ United Kingdom ■ Germany ■ France ■ Nordic ■ Italy ■ Spain ■ Japan

# Now Arriving on Track 5015!

## Glenair Series ITS

### Reverse Bayonet Connectors

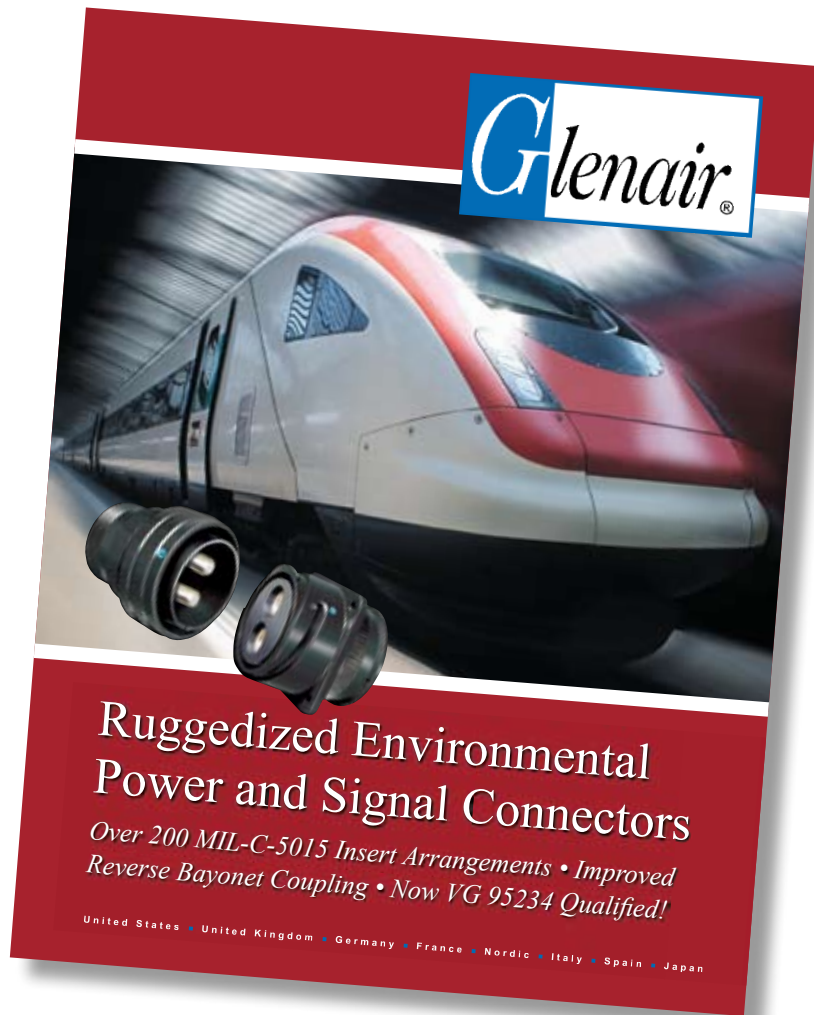

**EU Sales:** Glenair Connectors Italia, S.r.L. Tel: +39-02-91082121 Email: [sales-italia@glenair.com](mailto:sales-italia@glenair.com)

**North American Sales:** Glenair Connecticut, Tel: 203-741-1115 Email: [sales@glenair.com](mailto:sales@glenair.com)

**Factory Support:** Commital S.p.a. (Italy) Tel: +39-51-7821811 Email: [commital@commital.com](mailto:commital@commital.com)

United States • United Kingdom • Germany • Nordic • France • Italy • Spain

[www.glenair.com](http://www.glenair.com)

*A World of Interconnect Solutions*

**VG95328**  
**High Performance Crimp Contact**  
**Bayonet-Lock Signal Connectors (MIL-C-26482 Type)**



## Qualified VG95328 Connector and Backshell Products for High Performance Military and Industrial Applications

### Harsh Application Environments

The Glenair Series VG95328 Bayonet-Lock Signal Connector is ideally suited for all general and environmental applications that require a high-performance military type cylindrical connector with crimp-removable contacts. Qualified to VG95328, the bayonet mechanism provides fast and easy coupling, especially when the connector is situated in an awkward or hard to reach location.

Environmental protection to IP67 levels provides additional reliability and the flexibility to specify these rugged connectors in harsh

applications such as in machine tools and factory automation. Supplied crimp contacts are gold-plated copper alloy. Inserts are made from high-insulation synthetic rubber, oil and temperature resistant to  $-55^{\circ}\text{C}$  to  $+125^{\circ}\text{C}$ .

### Intermateability

The Series VG95328 Connector is interchangeable and intermateable with the wide range of industry-standard bayonet connectors designed around MIL-C-26482 and/or qualified to VG 95328.

- *High Performance Crimp Version with Contact Retention Clips and Sealed Inserts*
- *Environmental and Hermetic Versions*
- *2 Contact Sizes: #20 and #16.*
- *Closed Entry Socket Contacts*
- *18 Signal Contact Insert Arrangements, 3 to 61 Contacts*
- *Rear-Insertion/Front Release Snap-In Contacts*
- *Intermateable with Other MIL-C-26482 Products*
- *Ruggedized Contact Retention Clip*
- *Environmentally Sealed System*
- *Audible and Visual Coupling Indicators*
- *Keyed Polarization*
- *Optional Grounding Fingers on Plugs*

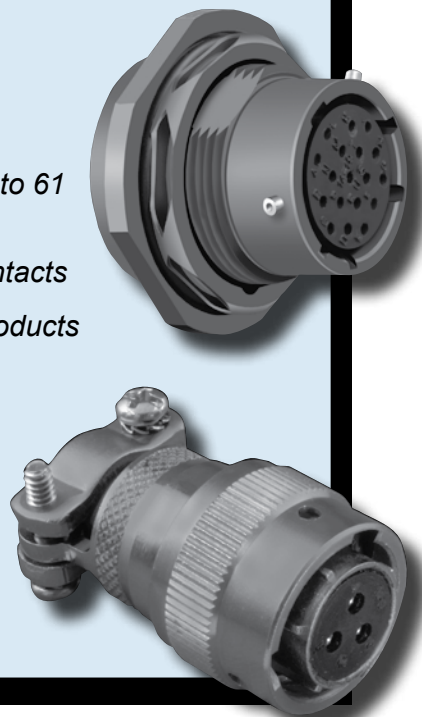

## VG95328

Glenair's qualified VG95328 miniature bayonet-lock connector series is based on the MIL-C-26482 Series I standard, and shares the same insert arrangements, shell dimensions, supported contacts and electrical performance ratings as MIL-C-26482 and Glenair's commercial equivalent product line, the IPT SE. The VG 95328 3-point bayonet coupling mechanism provides easy mating and positive locking resistance to vibration, shock, and other connector de-coupling forces in general duty and environmental interconnect systems such as military and commercial aircraft, medical equipment, industrial controls, factory robotics, instrumentation and other general electronic applications.

### Component Materials

VG95328 connectors are available in aluminum alloy and are supplied standard with an olive green cadmium finish IAW QQ-P-416. Supplied crimp contacts are gold plated copper alloy. Insulators are High Insulation Synthetic Rubber (Chloroprene):  $-55^{\circ}\text{C}/+125^{\circ}\text{C}$ .

### EMI and Environmental Applications

VG95328 Series connectors are perfectly suited for use in rugged applications where EEC compliance directives for electromagnetical compatibility is required. A complete range of EMI shield termination accessories are available for both overall as well as individual wire shields.

Equipped with the appropriate backshells and environmental sealing, the connectors are submersible for 48 hours up to a depth of two meters.



### Connector Accessories

Many of the VG95328 Series connectors come standard already paired with selected backshell accessories for most application requirements. See the accessory descriptions on the opposite page for more information. A full range of additional connector accessories including dustcaps and EMI gaskets are also available.

Please contact the factory for additional information or any of our worldwide sales and engineering facilities. Glenair's website, [www.glenair.com](http://www.glenair.com) also has complete information on these products, as well as other ruggedized power and signal connectors.

VG95328 offers a simplified ordering and part number format that combines the five standard connector shell styles with the most popular backshells and connector accessories. Available connector shell styles, backshell types and accessories include:

### **VG95328 Connector Shell Styles**

- *Front Panel Mount Square Flange Receptacle with Accessory Threads*
- *Rear Box Mount Square Flange Receptacle with No Accessory Threads*
- *Rear Box Mount Square Flange Through Bulkhead Receptacle*
- *Straight Plug Connector with Accessory Threads*
- *Rear Box Mount Jam Nut Receptacle*

### **VG95328 Integrated Backshell Types**

**Type N** Backshell for general-duty applications. This connector-backshell assembly is supplied with a general-duty backshell for the attachment of additional accessories such as MS 3057 cable clamps (ordered separately).

**Types A, C and D:** Backshell for general-duty environmental applications using unjacketed wire bundles. Additional environmental sealing is provided through an individual wire sealing grommet in the connector and an overall cable grommet seal in the backshell. No cable clamp supplied.

**Types B, E and K** Same as class above, but with cable clamp and bushing for strain-relief.

**Types J, S and V** Backshell for Heat Shrink Boot.

**Types M, R and T** Plug with backshell for EMI shield termination and/or heatshrink boot.

### **VG95328 Accessories**

- *Plug and receptacle protective covers with various lanyard styles for panel attachment*
- *Plug and receptacle covers with various lanyard styles for cable attachment*
- *Conductive and non-conductive gaskets for panel mount connectors*
- *Dummy stowage receptacles*
- *Consult factory for additional products*



## VG95328 Bayonet-Lock High Performance Crimp Contact Connector Materials and Finishes

The Glenair VG95328 miniature bayonet-lock connector series features a 3 point bayonet coupling mating interface with stainless steel coupling pins for advanced durability. Resilient closed entry inserts provide outstanding dielectric performance and environmental protection. Individual wire sealing grommets elevate the environmental protection rating to IP67. Conductive metal shells and plating provide a reliable ground plane for EMI applications when connectors are combined with appropriate shield termination backshells. Ground springs are also available in selected plug versions to further enhance EMC. Shells are keyed with five total alternate key positions. Connector shells are supplied standard in aluminum alloy with cadmium/olive drab passivation. For other plating options please consult Glenair's commercial equivalent catalog, *IPT and IPT SE Bayonet Lock Connectors*. The connectors are temperature rated from -55°C to +125°C (see opposite page for current ratings versus temperature). The VG95328 family consists of:

- 20 styles of connectors
- 9 Sizes of Connectors
- 2 Contact Sizes: #20 and #16
- 18 Insert Arrangements
- 2 Kinds of Contacts: Crimp Contacts (Standard); Solder Contacts (Hermetic Versions)

| MATERIALS                             |   |
|---------------------------------------|---|
| SHELLS                                | INSERTS (Temperature Range)                                     |
| Aluminum Alloy<br>IAW QQ-A-591 Shells | High Insulation Synthetic Rubber<br>(Chloroprene): -55°C/+125°C |
| Stainless Steel<br>Coupling Pins      | <b>CRIMP CONTACTS</b>   |
| Stainless Steel Spring                | Copper Alloy with Gold Plating Over Nickel                      |

| STANDARD FINISH<br>(For QQ-A-591 Aluminum Shells) |  |
|---|--|
| Requirements                                      | Cadmium with Olive Drab<br>Passivation<br>IAW QQ-P-416 |
| Thermal Shock                                     | -55°C + 125°C  |
| Salt Spray After<br>Thermal Shock                 | 500 hour   |
| Electrical Conductivity                           | Very Good  |
| Abrasion Resistance                               | Very Good  |

# VG95328 Bayonet-Lock High Performance Crimp Contact Connector Technical Data



| Service Rating |                      |                      |                 |
|----------------|----------------------|----------------------|-----------------|
| Class          | Operating voltage AC | Operating voltage DC | Test voltage AC |
| I              | 600                  | 700                  | 1500            |
| II             | 1000                 | 1250                 | 2300            |

| Potential Drop |              |                |
|----------------|--------------|----------------|
| Contact size   | Test current | Potential drop |
| 20             | 7.5 A        | 25 mV          |
| 16             | 13.0 A       | 21 mV          |

Rated Current Versus Temperature

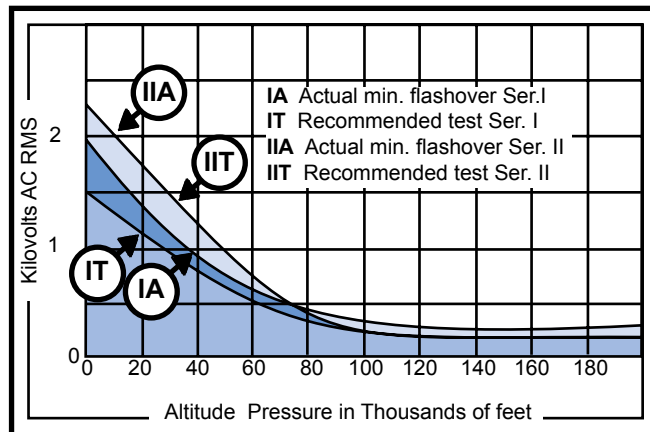
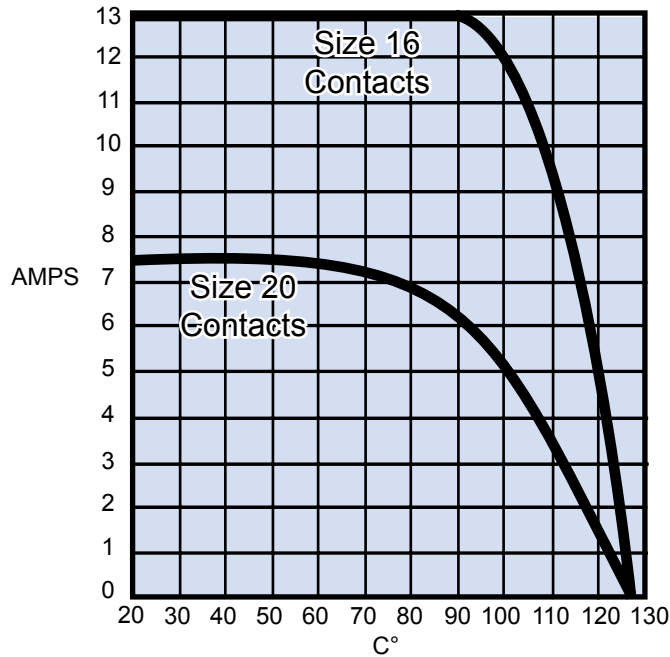



**VG95328 Bayonet-Lock  
High Performance Crimp Contact (MIL-C-26482 Type)  
How to Order • Cross Reference**

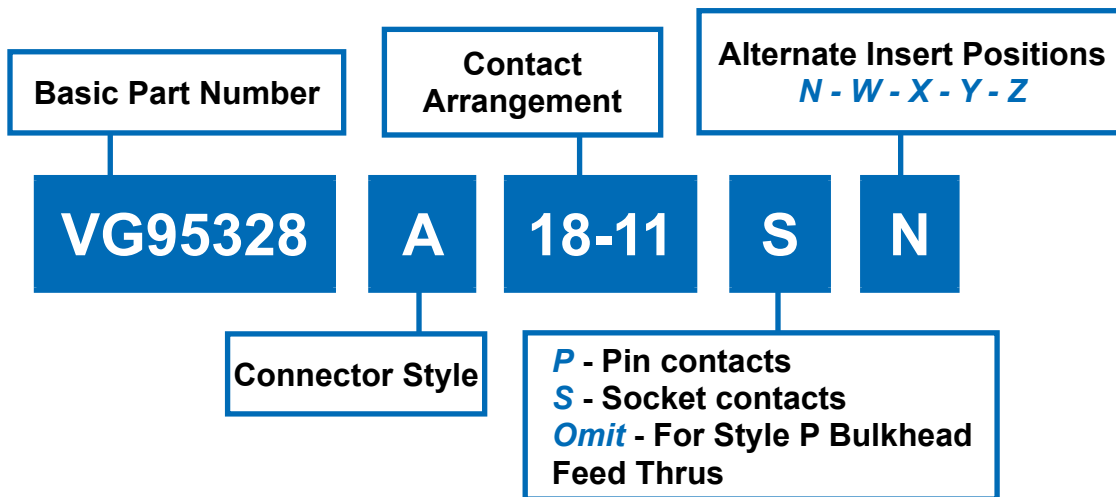

| Connector Cross Reference |           |                  |
|---------------------------|-----------|------------------|
| VG95328 Connectors        | MS        | Glenair          |
| VG95328 A                 | MS 3120 E | IPT 00 SE        |
| VG95328 B                 | MS 3120 F | IPT 00 SE ... SR |
| VG95328 C                 | MS 3122 E | IPT 02 SE        |
| VG95328 D                 | MS 3124 E | IPT 07 SE        |
| VG95328 E                 | MS 3124 F | IPT 07 SE ... SR |
| VG95328 F                 | N.A.      | N. A.            |
| VG95328 G                 | N.A.      | N. A.            |
| VG95328 H                 | MS 3112 E | IPT 02 E         |
| VG95328 J                 | N.A.      | IPT 06 GSE       |
| VG95328 K                 | MS 3126 F | IPT 06 SE ... SR |
| VG95328 L                 | N.A.      | N. A.            |
| VG95328 M                 | N.A.      | IPT G 06 MSE     |
| VG95328 N                 | N.A.      | IPT G 06 ASE     |
| VG95328 P                 | MS 3119 E | IPT 02 PP        |
| VG95328 R                 | N.A.      | IPT 00 MSE       |
| VG95328 S                 | N.A.      | IPT 07 GSE       |
| VG95328 T                 | N.A.      | IPT 07 MSE       |
| VG95328 U                 | N.A.      | N. A.            |
| VG95328 V                 | N.A.      | IPT G 06 GSE     |
| VG95328 W                 | N.A.      | N. A.            |

| Accessory Cross Reference |           |             |
|---------------------------|-----------|-------------|
| VG95328 Accessories       | MS        | Glenair     |
| VG95328 Z1 A              | MS 3181 C | IPT 3181 C  |
| VG95328 Z1 B              | N.A.      | IPT 3181 CF |
| VG95328 Z1 C              | N.A.      | N. A.       |
| VG95328 Z2 A              | MS 3180 C | IPT 3180 C  |
| VG95328 Z2 B              | N.A.      | IPT 3180 CF |
| VG95328 Z2 C              | N.A.      | N. A.       |
| VG95328 Z3 C              | N.A.      | IPT 3181 NF |
| VG95328 T07 A             | N.A.      | 10-101949   |
| VG95328 T07 B             | N.A.      | 10-101949 S |
| VG95328 T07 C             | MS 3115   | IPT 3115    |
| VG95328 T07 D             | N.A.      | N. A.       |



Glenair offers a complete commercial equivalent product line, the Series IPT SE, that conforms exactly to the VG95328 standard but also offers additional connector styles, backshell types, plating codes and other enhancements. For complete product information see the *IPT and IPT SE Bayonet-Lock Connector Catalog*.

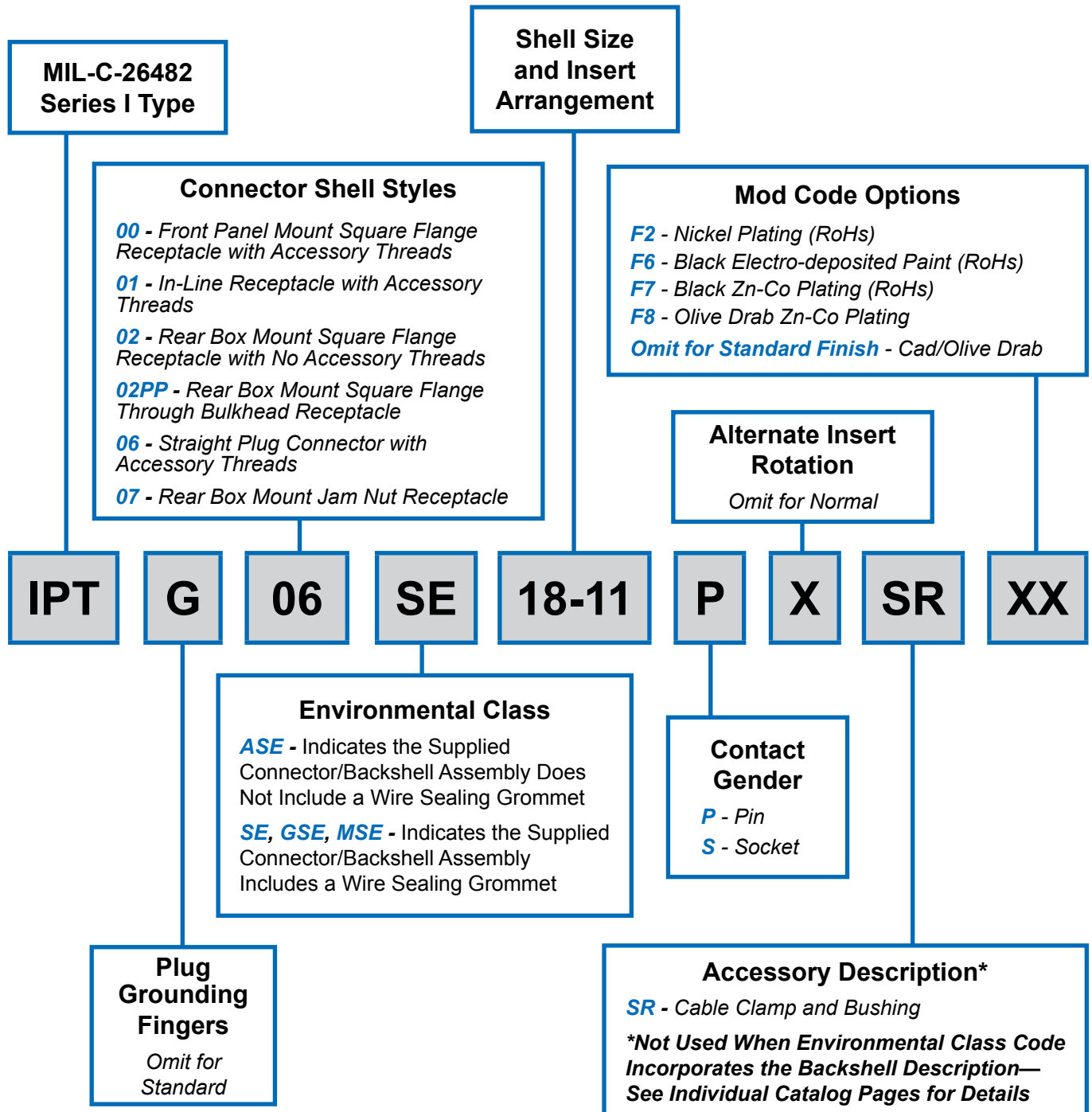

## VG95328 Bayonet-Lock Connectors Solder Contacts for Hermetic Styles F, G and H Plus Crimp Contact Assembly Tools

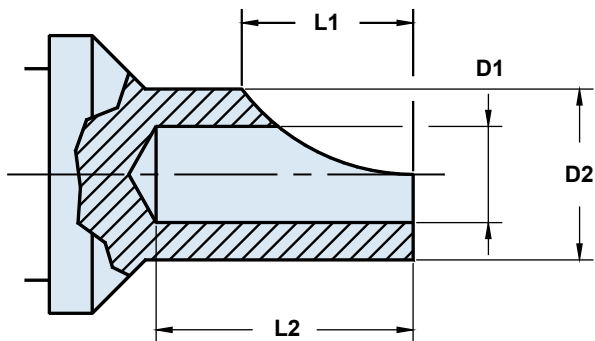

| Termination Dimensions |         |         |      |              |         |       |
|------------------------|---------|---------|------|--------------|---------|-------|
| Contact size           | D1 min. | D2 min. | Max. | L1 +1.5 -0.4 | L2 ±0.8 | Color |
| 20                     | 1.1     | 1.5     | 2.2  | 3.2          | 2.4     | Red   |
| 16                     | 1.8     | 2.4     | 2.9  | 4.8          | 3.2     | Blue  |

| VG95328 Crimp Connector Assembly Tools |                     |                      |                         |        |                |              |                 |    |                |                  |
|--|---------------------|----------------------|-------------------------|--------|----------------|--------------|-----------------|----|----------------|------------------|
| Contact Size                           | Wires Cross Section | Manual Crimping Tool | Pneumatic Crimping Tool | Turret | Insertion Tool | Removal Tool | mm <sup>2</sup> |    | AWG            |                  |
|  |                     |                      |                         |        |                |              |                 |    |                |                  |
| 10-314980-20P                          |                     |                      |                         |        |                |              |                 |    |                |                  |
| 10-314980-20S                          |                     |                      |                         |        |                |              | 20              | 20 | M.105001 [AF8] | M.105003 [WA27F] |
| 10-314980-16P                          |                     |                      |                         |        |                |              |                 |    |                |                  |
| 10-314980-16S                          |                     |                      |                         |        |                |              | 16              | 16 | M.105001 [AF8] | M.105003 [WA27F] |

DMC Part Numbers indicated in [parentheses]

**VG95328 Bayonet-Lock Connectors  
Crimp Contact Dimensions  
Pin and Socket**

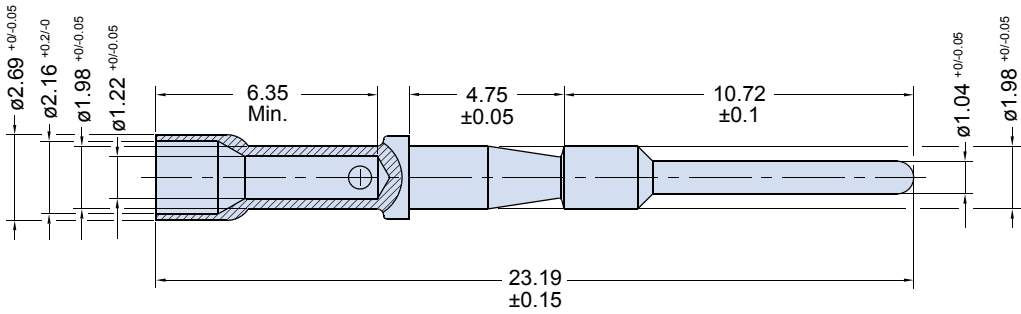

**Size 20 Pin Contact  
10-314980-20P**

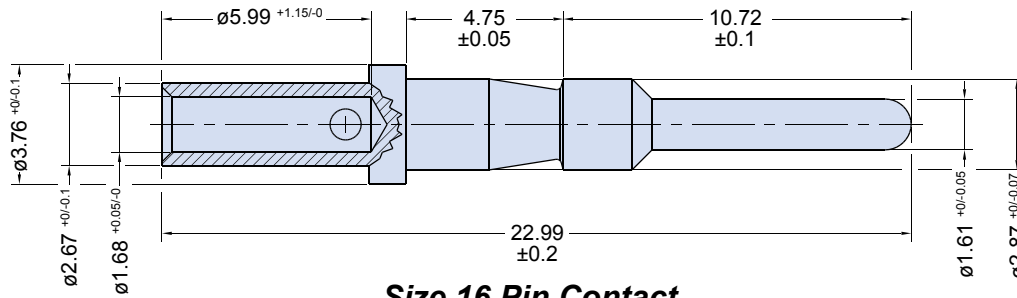

**Size 16 Pin Contact  
10-314980-16P**

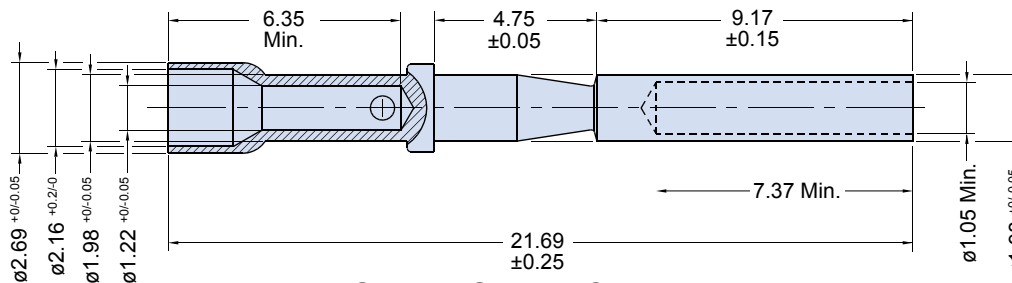

**Size 20 Socket Contact  
10-314980-20S**

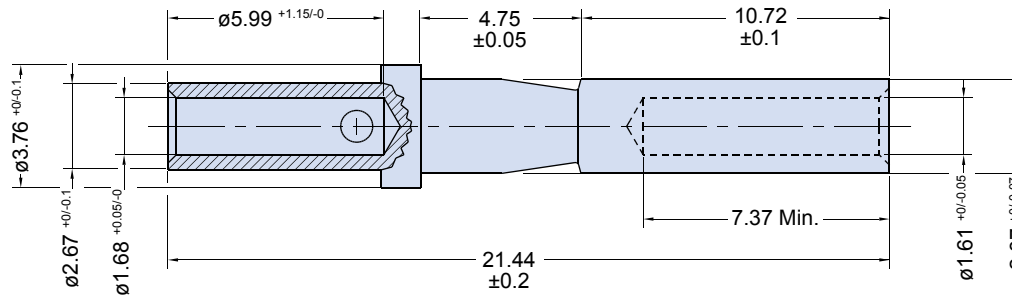

**Size 16 Socket Contact  
10-314980-16S**

**Sealing Plugs for Socket Cavity**

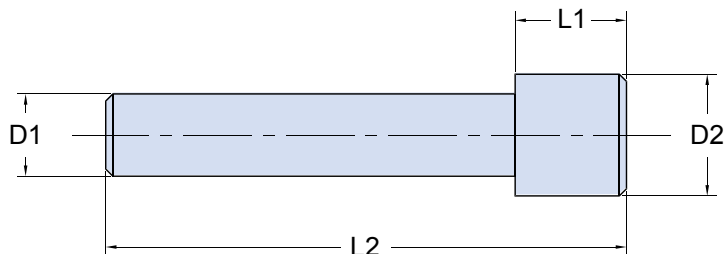

| SEALING PLUG DIMENSIONS |            |            |            |            |       |
|-------------------------|------------|------------|------------|------------|-------|
| Part Number             | D1<br>±0.1 | D2<br>±0.2 | L1<br>±0.1 | L2<br>±0.3 | Color |
| DIN 65194-20            | 1.62       | 2.3        | 3.5        | 14.5       | Red   |
| DIN 65194-16            | 2.30       | 3.4        | 3.1        | 14.5       | Blue  |

| Arrangement | Cl. Isol. Rating | Dim. contact size |    |
|-------------|------------------|-------------------|----|
|             |                  | 20                | 16 |
| 8 - 3A      | I                | 3                 |    |
| 10 - 6      | I                | 6                 |    |
| 12 - 3      | II               |                   | 3  |
| 12 - 10     | I                | 10                |    |
| 14 - 5      | II               |                   | 5  |
| 14 - 12     | I                | 8                 | 4  |
| 14 - 15     | I                | 14                | 1  |
| 14 - 19     | I                | 19                |    |
| 16 - 8      | II               |                   | 8  |
| 16 - 23     | I                | 22                | 1  |
| 16 - 26     | I                | 26                |    |
| 18 - 11     | II               |                   | 11 |
| 18 - 32     | I                | 32                |    |
| 20 - 16     | II               |                   | 16 |
| 20 - 41     | I                | 41                |    |
| 22 - 21     | II               |                   | 21 |
| 22 - 55     | I                | 55                |    |
| 24 - 61     | I                | 61                |    |

| Arrangement | Degrees |       |     |     |
|-------------|---------|-------|-----|-----|
|             | W       | X     | Y   | Z   |
| 8 - 3A      | 60      | (120) |     |     |
| 10 - 6      | 90      |       |     |     |
| 12 - 3      |         |       | 180 |     |
| 12 - 10     | 60      | 155   | 270 | 295 |
| 14 - 5      | 40      | 92    | 184 | 273 |
| 14 - 12     | 43      | 90    |     |     |
| 14 - 15     | 17      | 110   | 155 | 234 |
| 14 - 19     | 30      | 165   | 315 |     |
| 16 - 8      | 54      | 152   | 180 | 331 |
| 16 - 23     | 158     | 270   |     |     |
| 16 - 26     | 60      |       | 275 | 338 |
| 18 - 11     | 62      | 119   | 241 | 340 |
| 18 - 32     | 85      | 138   | 222 | 265 |
| 20 - 16     | 238     | 318   | 333 | 347 |
| 20 - 41     | 45      | 126   | 225 |     |
| 22 - 21     | 16      | 135   | 175 | 349 |
| 22 - 55     | 30      | 142   | 226 | 314 |
| 24 - 61     | 90      | 180   | 270 | 324 |

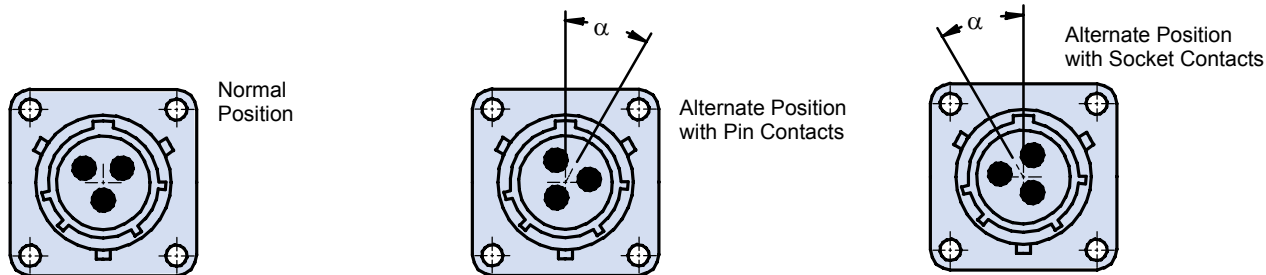

# VG95328 Available Insert Arrangements



## 3 Contacts

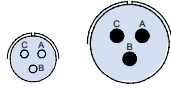

|                 |      |      |
|-----------------|------|------|
| Arrangement:    | 8-3A | 12-3 |
| Contact Size:   | 20   | 16   |
| Service Rating: | I    | II   |

## 6 Contacts



|                 |      |
|-----------------|------|
| Arrangement:    | 10-6 |
| Contact Size:   | 20   |
| Service Rating: | I    |

## 10 Contacts



|                 |       |
|-----------------|-------|
| Arrangement:    | 12-10 |
| Contact Size:   | 20    |
| Service Rating: | I     |

## 12 Contacts

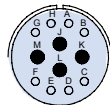

|                 |            |
|-----------------|------------|
| Arrangement:    | 14-12      |
| Contact Size:   | 8-20, 4-16 |
| Service Rating: | I          |

## 16 Contacts

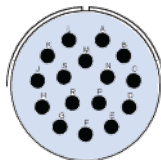

|                 |       |
|-----------------|-------|
| Arrangement:    | 20-16 |
| Contact Size:   | 16    |
| Service Rating: | II    |

## 5 Contacts

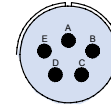

|                 |      |
|-----------------|------|
| Arrangement:    | 14-5 |
| Contact Size:   | 16   |
| Service Rating: | II   |

## 8 Contacts

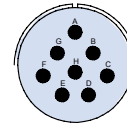

|                 |      |
|-----------------|------|
| Arrangement:    | 16-8 |
| Contact Size:   | 16   |
| Service Rating: | II   |

## 11 Contacts

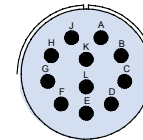

|                 |       |
|-----------------|-------|
| Arrangement:    | 18-11 |
| Contact Size:   | 16    |
| Service Rating: | II    |

## 15 Contacts

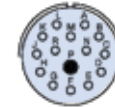

|                 |             |
|-----------------|-------------|
| Arrangement:    | 14-15       |
| Contact Size:   | 14-20, 1-16 |
| Service Rating: | I           |

## 19 Contacts

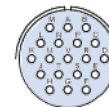

|                 |       |
|-----------------|-------|
| Arrangement:    | 14-19 |
| Contact Size:   | 20    |
| Service Rating: | I     |

### Contact Legend



20



16

\*Consult Factory

**21 Contacts**

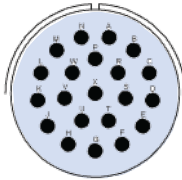

|                 |        |
|-----------------|--------|
| Arrangement:    | 22-21* |
| Contact Size:   | 16     |
| Service Rating: | II     |

**26 Contacts**

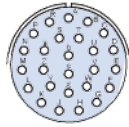

|                 |       |
|-----------------|-------|
| Arrangement:    | 16-26 |
| Contact Size:   | 20    |
| Service Rating: | I     |

**41 Contacts**

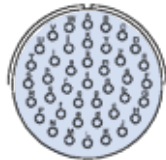

|                 |       |
|-----------------|-------|
| Arrangement:    | 20-41 |
| Contact Size:   | 20    |
| Service Rating: | I     |

**61 Contacts**

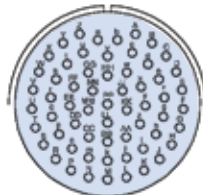

|                 |       |
|-----------------|-------|
| Arrangement:    | 24-61 |
| Contact Size:   | 20    |
| Service Rating: | I     |

**23 Contacts**

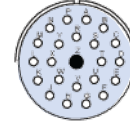

|                 |             |
|-----------------|-------------|
| Arrangement:    | 16-23       |
| Contact Size:   | 22-20, 1-16 |
| Service Rating: | I           |

**32 Contacts**

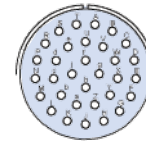

|                 |       |
|-----------------|-------|
| Arrangement:    | 18-32 |
| Contact Size:   | 20    |
| Service Rating: | I     |

**55 Contacts**

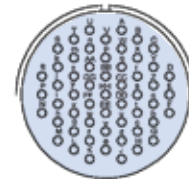

|                 |       |
|-----------------|-------|
| Arrangement:    | 22-55 |
| Contact Size:   | 20    |
| Service Rating: | I     |

Contact Legend



20



16

\*Consult Factory

# VG95328 Bayonet-Lock High Performance Crimp (MIL-C-26482 Type) Fastener Height Requirements and Panel Cutout Dimensions



For front panel mount square flange connectors the "A" dimension indicates the measured maximums that mounting hardware can stand proud from the connector flange before it will interfere with connector mating. For rear box mount square flange connectors the same "A" column maximum dimensions apply, but in this case the measurement taken includes the thickness of the panel wall or box (so the mounting hardware needs to be correspondingly shorter). Column "A1" defines the maximums for the bulkhead feedthrough product before mounting hardware interferes with mating.

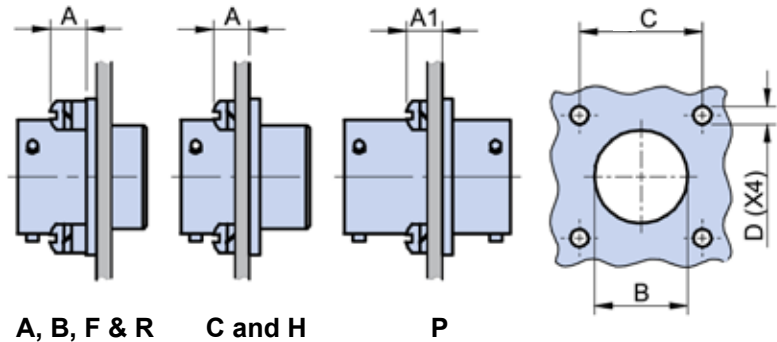

| Panel Thickness and Panel Cutout for Square Flange Mount Receptacles |       |        |           |        |         |
|--|-------|--------|-----------|--------|---------|
| Shell size   | A max | A1 max | B +0.2 -0 | C ±0.1 | D ±0.12 |
| 8  | 2.2   | 5.54   | 15.1      | 15.10  | 3.04    |
| 10   | 2.2   | 5.54   | 18.3      | 18.25  | 3.04    |
| 12   | 2.2   | 5.54   | 20.6      | 20.60  | 3.04    |
| 14   | 2.2   | 5.54   | 23.0      | 23.00  | 3.04    |
| 16   | 2.2   | 5.54   | 24.6      | 24.60  | 3.04    |
| 18   | 2.2   | 5.54   | 27.0      | 27.00  | 3.04    |
| 20   | 5.4   | 8.74   | 29.4      | 29.35  | 3.04    |
| 22   | 5.4   | 8.74   | 31.8      | 31.75  | 3.04    |
| 24   | 5.4   | 7.9    | 34.9      | 34.90  | 3.73    |

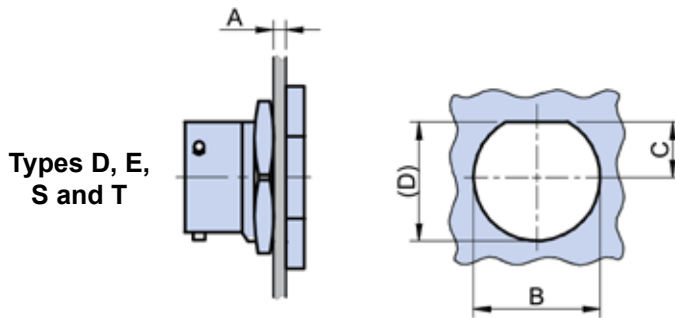

| Panel Thickness and Panel Cutout for Jam Nut Mount Receptacles |             |            |            |      |
|--|-------------|------------|------------|------|
| Shell size   | A min - max | B +0.25 -0 | C +0 -0.25 | D    |
| 8  | 1.6 - 3.2   | 14.5       | 6.55       | 13.8 |
| 10   | 1.6 - 3.2   | 17.7       | 8.15       | 17.0 |
| 12   | 1.6 - 3.2   | 22.5       | 9.85       | 21.1 |
| 14   | 1.6 - 3.2   | 25.6       | 11.50      | 24.3 |
| 16   | 1.6 - 3.2   | 28.8       | 13.10      | 27.5 |
| 18   | 1.6 - 3.2   | 32.0       | 14.70      | 30.7 |
| 20   | 1.6 - 3.3   | 35.2       | 16.30      | 33.9 |
| 22   | 1.6 - 3.3   | 38.3       | 17.95      | 37.1 |
| 24   | 1.6 - 3.3   | 41.5       | 19.25      | 40.0 |

**VG95328 A**  
**Bayonet-Lock**  
**Front Panel Mount Square Flange Receptacle**  
**with Backshell**

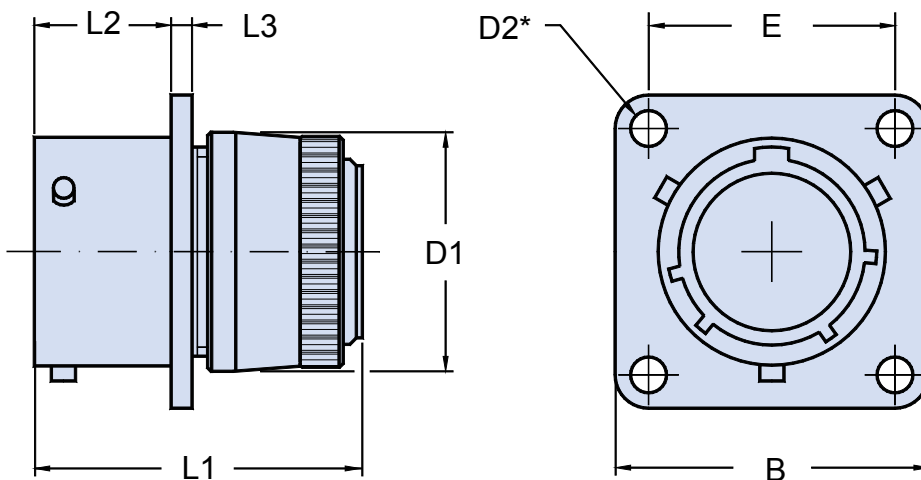
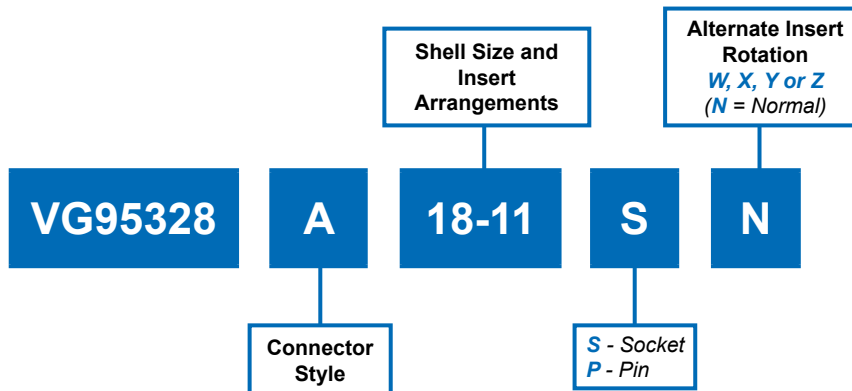

**TABLE I: DIMENSIONS**

| Shell Size | B<br>Max. | D1<br>Max. | D2<br>Min. | E<br>±0.15 | L1<br>Max. | L2<br>+ 0.8<br>- 0 | L3<br>Max. | Max-Weight<br>in Grams |
|------------|-----------|------------|------------|------------|------------|--------------------|------------|------------------------|
| 8          | 21.03     | 15.44      | 2.9        | 15.08      | 40         | 10.94              | 2.0        | 10                     |
| 10         | 24.23     | 18.64      | 2.9        | 18.26      | 40         | 10.94              | 2.0        | 14                     |
| 12         | 26.59     | 21.79      | 2.9        | 20.62      | 40         | 10.94              | 2.0        | 22                     |
| 14         | 28.98     | 25.00      | 2.9        | 23.01      | 40         | 10.94              | 2.0        | 29                     |
| 16         | 31.34     | 28.19      | 2.9        | 24.61      | 40         | 10.94              | 2.0        | 37                     |
| 18         | 33.73     | 31.34      | 2.9        | 26.97      | 40         | 10.94              | 2.0        | 45                     |
| 20         | 36.90     | 34.54      | 2.9        | 29.36      | 44         | 14.12              | 2.8        | 50                     |
| 22         | 40.08     | 37.69      | 2.9        | 31.75      | 44         | 14.12              | 2.8        | 55                     |
| 24         | 43.25     | 40.89      | 3.6        | 34.92      | 44         | 14.86              | 2.8        | 65                     |

\* Through Mounting Holes



# VG95328 A Bayonet-Lock Front Panel Mount Square Flange Receptacle with Backshell



VG95328  
Connectors

| Contact Arrangements |                  |                   |    |
|----------------------|------------------|-------------------|----|
| Arrangement          | Cl. Isol. Rating | Dim. contact size |    |
|                      |                  | 20                | 16 |
| 8 - 3A               | I                | 3                 |    |
| 10 - 6               | I                | 6                 |    |
| 12 - 3               | II               |                   | 3  |
| 12 - 10              | I                | 10                |    |
| 14 - 5               | II               |                   | 5  |
| 14 - 12              | I                | 8                 | 4  |
| 14 - 15              | I                | 14                | 1  |
| 14 - 19              | I                | 19                |    |
| 16 - 8               | II               |                   | 8  |
| 16 - 23              | I                | 22                | 1  |
| 16 - 26              | I                | 26                |    |
| 18 - 11              | II               |                   | 11 |
| 18 - 32              | I                | 32                |    |
| 20 - 16              | II               |                   | 16 |
| 20 - 41              | I                | 41                |    |
| 22 - 21              | II               |                   | 21 |
| 22 - 55              | I                | 55                |    |
| 24 - 61              | I                | 61                |    |

| Alternate Insert Orientations |         |       |     |     |
|-------------------------------|---------|-------|-----|-----|
| Arrangement                   | Degrees |       |     |     |
|                               | W       | X     | Y   | Z   |
| 8 - 3A                        | 60      | (120) |     |     |
| 10 - 6                        | 90      |       |     |     |
| 12 - 3                        |         |       | 180 |     |
| 12 - 10                       | 60      | 155   | 270 | 295 |
| 14 - 5                        | 40      | 92    | 184 | 273 |
| 14 - 12                       | 43      | 90    |     |     |
| 14 - 15                       | 17      | 110   | 155 | 234 |
| 14 - 19                       | 30      | 165   | 315 |     |
| 16 - 8                        | 54      | 152   | 180 | 331 |
| 16 - 23                       | 158     | 270   |     |     |
| 16 - 26                       | 60      |       | 275 | 338 |
| 18 - 11                       | 62      | 119   | 241 | 340 |
| 18 - 32                       | 85      | 138   | 222 | 265 |
| 20 - 16                       | 238     | 318   | 333 | 347 |
| 20 - 41                       | 45      | 126   | 225 |     |
| 22 - 21                       | 16      | 135   | 175 | 349 |
| 22 - 55                       | 30      | 142   | 226 | 314 |
| 24 - 61                       | 90      | 180   | 270 | 324 |

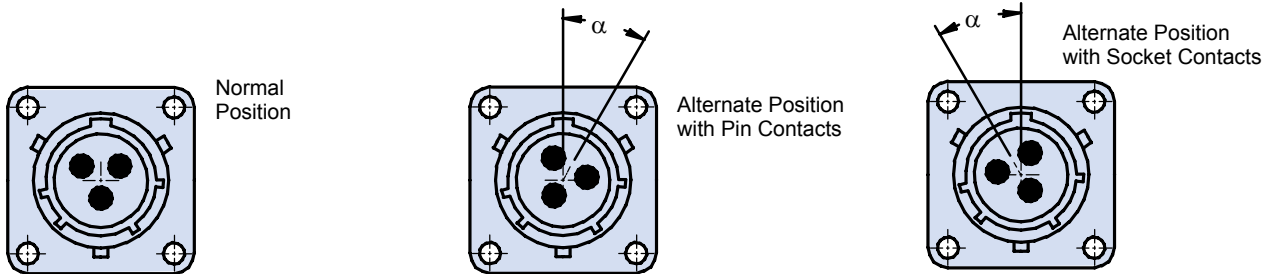

| MATERIALS                             |   |
|---------------------------------------|---|
| <b>SHELLS</b>                         | <b>INSERTS (Temperature Range)</b>                              |
| Aluminum Alloy<br>IAW QQ-A-591 Shells | High Insulation Synthetic Rubber<br>(Chloroprene): -55°C/+125°C |
| Stainless Steel<br>Coupling Pins      | <b>CRIMP CONTACTS</b>   |
| Stainless Steel Spring                | Copper Alloy with Gold Plating Over Nickel                      |

| STANDARD FINISH<br>(For QQ-A-591 Aluminum Shells) |   |
|---|---|
| <b>Requirements</b>                               | <b>Cadmium with Olive Drab Passivation<br/>IAW QQ-P-416</b> |
| Thermal Shock                                     | -55°C + 125°C   |
| Salt Spray After Thermal Shock                    | 500 hour  |
| Electrical Conductivity                           | Very Good   |
| Abrasion Resistance                               | Very Good   |

See Page 13 for Panel Thickness and Cutout Dimensions

**VG95328 B**  
**Bayonet-Lock**  
**Front Panel Mount Square Flange Receptacle**  
**with Backshell, Cable Clamp and Bushing**

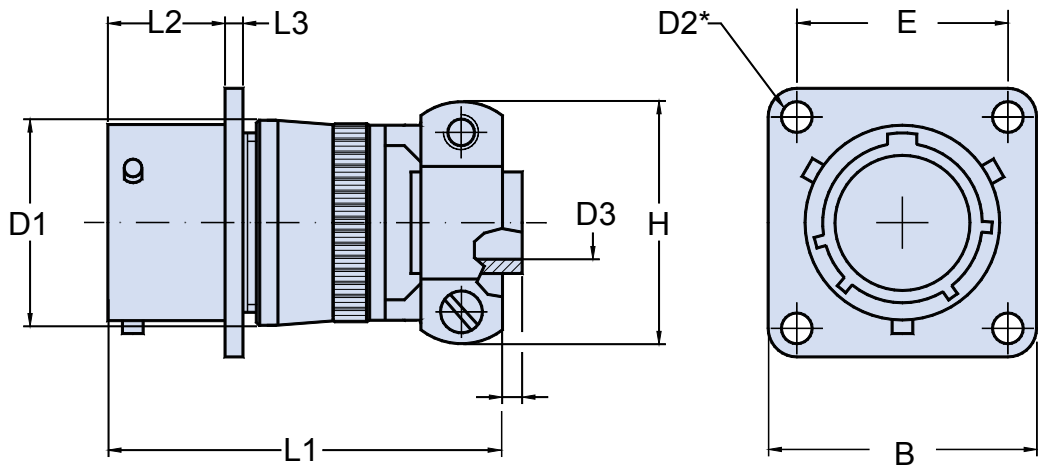
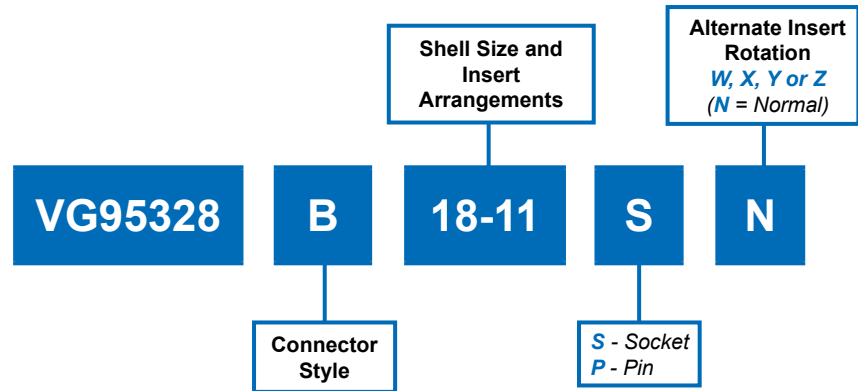

**TABLE I: DIMENSIONS**

| Shell size | B<br>Max. | D1<br>Max. | D2<br>Min. | D3<br>+ 0.3<br>- 0.7 | E<br>±0.15 | H<br>Max. | L1<br>Max. | L2<br>+ 0.8<br>- 0 | L3<br>Max. | Max.<br>Weight in<br>Grams |
|------------|-----------|------------|------------|----------------------|------------|-----------|------------|--------------------|------------|----------------------------|
| 8          | 21.03     | 15.44      | 2.9        | 3.2                  | 15.08      | 21.1      | 61.5       | 10.94              | 2.0        | 20                         |
| 10         | 24.23     | 18.64      | 2.9        | 4.8                  | 18.26      | 22.7      | 61.5       | 10.94              | 2.0        | 22                         |
| 12         | 26.59     | 27.79      | 2.9        | 7.9                  | 20.62      | 25.9      | 61.5       | 10.94              | 2.0        | 29                         |
| 14         | 28.98     | 25.00      | 2.9        | 9.5                  | 23.01      | 29.0      | 61.5       | 10.94              | 2.0        | 40                         |
| 16         | 31.34     | 28.19      | 2.9        | 12.7                 | 24.61      | 30.6      | 64.4       | 10.94              | 2.0        | 51                         |
| 18         | 33.73     | 31.34      | 2.9        | 15.9                 | 26.97      | 37.4      | 64.4       | 10.94              | 2.0        | 62                         |
| 20         | 36.90     | 34.54      | 2.9        | 15.9                 | 29.36      | 37.4      | 71.1       | 14.12              | 2.8        | 70                         |
| 22         | 40.08     | 37.69      | 2.9        | 19.1                 | 31.75      | 42.1      | 71.1       | 14.12              | 2.8        | 75                         |
| 24         | 43.25     | 40.89      | 3.6        | 20.3                 | 34.92      | 44.5      | 73.6       | 14.96              | 2.8        | 87                         |

\* Through Mounting Holes

# VG95328 B Bayonet-Lock Front Panel Mount Square Flange Receptacle with Backshell, Cable Clamp and Bushing



VG95328  
Connectors

| Contact Arrangements |                  |                   |    |
|----------------------|------------------|-------------------|----|
| Arrangement          | Cl. Isol. Rating | Dim. contact size |    |
|                      |                  | 20                | 16 |
| 8 - 3A               | I                | 3                 |    |
| 10 - 6               | I                | 6                 |    |
| 12 - 3               | II               |                   | 3  |
| 12 - 10              | I                | 10                |    |
| 14 - 5               | II               |                   | 5  |
| 14 - 12              | I                | 8                 | 4  |
| 14 - 15              | I                | 14                | 1  |
| 14 - 19              | I                | 19                |    |
| 16 - 8               | II               |                   | 8  |
| 16 - 23              | I                | 22                | 1  |
| 16 - 26              | I                | 26                |    |
| 18 - 11              | II               |                   | 11 |
| 18 - 32              | I                | 32                |    |
| 20 - 16              | II               |                   | 16 |
| 20 - 41              | I                | 41                |    |
| 22 - 21              | II               |                   | 21 |
| 22 - 55              | I                | 55                |    |
| 24 - 61              | I                | 61                |    |

| Alternate Insert Orientations |         |       |     |     |
|-------------------------------|---------|-------|-----|-----|
| Arrangement                   | Degrees |       |     |     |
|                               | W       | X     | Y   | Z   |
| 8 - 3A                        | 60      | (120) |     |     |
| 10 - 6                        | 90      |       |     |     |
| 12 - 3                        |         |       | 180 |     |
| 12 - 10                       | 60      | 155   | 270 | 295 |
| 14 - 5                        | 40      | 92    | 184 | 273 |
| 14 - 12                       | 43      | 90    |     |     |
| 14 - 15                       | 17      | 110   | 155 | 234 |
| 14 - 19                       | 30      | 165   | 315 |     |
| 16 - 8                        | 54      | 152   | 180 | 331 |
| 16 - 23                       | 158     | 270   |     |     |
| 16 - 26                       | 60      |       | 275 | 338 |
| 18 - 11                       | 62      | 119   | 241 | 340 |
| 18 - 32                       | 85      | 138   | 222 | 265 |
| 20 - 16                       | 238     | 318   | 333 | 347 |
| 20 - 41                       | 45      | 126   | 225 |     |
| 22 - 21                       | 16      | 135   | 175 | 349 |
| 22 - 55                       | 30      | 142   | 226 | 314 |
| 24 - 61                       | 90      | 180   | 270 | 324 |

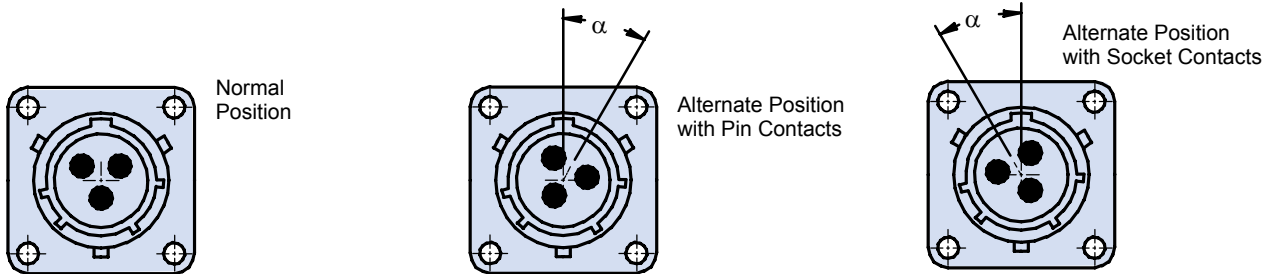

| MATERIALS                             |   |
|---------------------------------------|---|
| <b>SHELLS</b>                         | <b>INSERTS (Temperature Range)</b>                              |
| Aluminum Alloy<br>IAW QQ-A-591 Shells | High Insulation Synthetic Rubber<br>(Chloroprene): -55°C/+125°C |
| Stainless Steel<br>Coupling Pins      | <b>CRIMP CONTACTS</b>   |
| Stainless Steel Spring                | Copper Alloy with Gold Plating Over Nickel                      |

| STANDARD FINISH<br>(For QQ-A-591 Aluminum Shells) |   |
|---|---|
| <b>Requirements</b>                               | <b>Cadmium with Olive<br/>Drab Passivation<br/>IAW QQ-P-416</b> |
| Thermal Shock                                     | -55°C + 125°C   |
| Salt Spray After<br>Thermal Shock                 | 500 hour  |
| Electical Conductivity                            | Very Good   |
| Abrasion Resistance                               | Very Good   |

See Page 13 for Panel Thickness and Cutout Dimensions

**VG95328 C**  
**Bayonet-Lock**  
**Rear Box Mount Square Flange Receptacle**

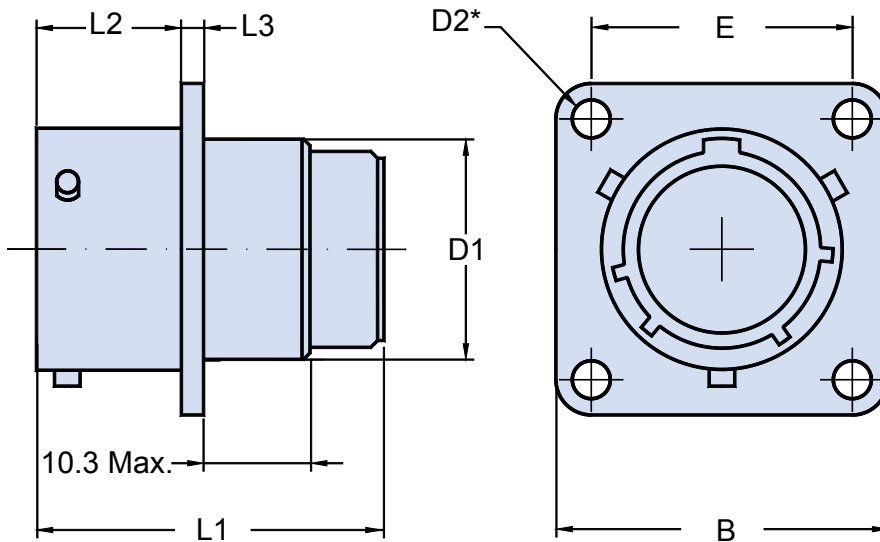
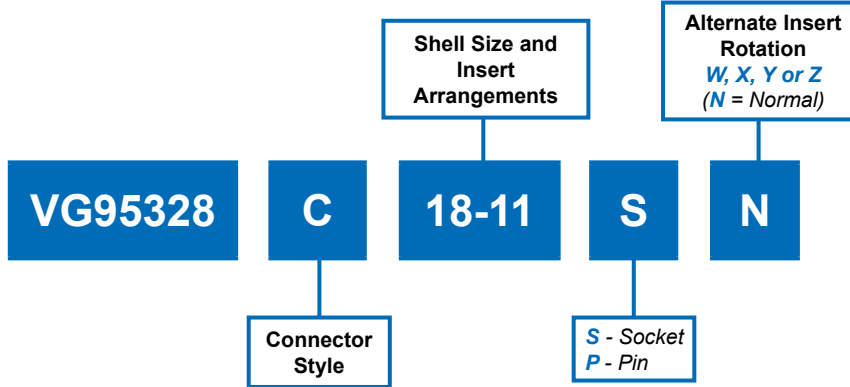

**TABLE I: DIMENSIONS**

| Shell size | B Max. | D1 +0.8 -0.6 | D2 Min. | E ± 0.15 | L1 Max. | L2 +0.8 -0 | L3 Max. | Maximum Weight in Grams |
|------------|--------|--------------|---------|----------|---------|------------|---------|-------------------------|
| 8          | 21.03  | 11.2         | 2.9     | 15.08    | 33.5    | 10.94      | 2.0     | 6                       |
| 10         | 24.23  | 14.3         | 2.9     | 18.26    | 33.5    | 10.94      | 2.0     | 7                       |
| 12         | 26.59  | 17.5         | 2.9     | 20.62    | 33.5    | 10.94      | 2.0     | 10                      |
| 14         | 28.98  | 20.7         | 2.9     | 23.01    | 33.5    | 10.94      | 2.0     | 12                      |
| 16         | 31.34  | 23.9         | 2.9     | 24.61    | 33.5    | 10.94      | 2.0     | 14                      |
| 18         | 33.73  | 27.0         | 2.9     | 26.97    | 33.5    | 10.94      | 2.0     | 17                      |
| 20         | 36.90  | 30.2         | 2.9     | 29.36    | 34.7    | 14.12      | 2.8     | 21                      |
| 22         | 40.08  | 33.4         | 2.9     | 31.75    | 36.0    | 14.12      | 2.8     | 25                      |
| 24         | 43.25  | 36.6         | 3.6     | 34.92    | 36.0    | 14.96      | 2.8     | 27                      |

\* Through Mounting Holes

# VG95328 C Bayonet-Lock Rear Box Mount Square Flange Receptacle



VG95328  
Connectors

| Contact Arrangements |                  |                   |    |
|----------------------|------------------|-------------------|----|
| Arrangement          | Cl. Isol. Rating | Dim. contact size |    |
|                      |                  | 20                | 16 |
| 8 - 3A               | I                | 3                 |    |
| 10 - 6               | I                | 6                 |    |
| 12 - 3               | II               |                   | 3  |
| 12 - 10              | I                | 10                |    |
| 14 - 5               | II               |                   | 5  |
| 14 - 12              | I                | 8                 | 4  |
| 14 - 15              | I                | 14                | 1  |
| 14 - 19              | I                | 19                |    |
| 16 - 8               | II               |                   | 8  |
| 16 - 23              | I                | 22                | 1  |
| 16 - 26              | I                | 26                |    |
| 18 - 11              | II               |                   | 11 |
| 18 - 32              | I                | 32                |    |
| 20 - 16              | II               |                   | 16 |
| 20 - 41              | I                | 41                |    |
| 22 - 21              | II               |                   | 21 |
| 22 - 55              | I                | 55                |    |
| 24 - 61              | I                | 61                |    |

| Alternate Insert Orientations |         |       |     |     |
|-------------------------------|---------|-------|-----|-----|
| Arrangement                   | Degrees |       |     |     |
|                               | W       | X     | Y   | Z   |
| 8 - 3A                        | 60      | (120) |     |     |
| 10 - 6                        | 90      |       |     |     |
| 12 - 3                        |         |       | 180 |     |
| 12 - 10                       | 60      | 155   | 270 | 295 |
| 14 - 5                        | 40      | 92    | 184 | 273 |
| 14 - 12                       | 43      | 90    |     |     |
| 14 - 15                       | 17      | 110   | 155 | 234 |
| 14 - 19                       | 30      | 165   | 315 |     |
| 16 - 8                        | 54      | 152   | 180 | 331 |
| 16 - 23                       | 158     | 270   |     |     |
| 16 - 26                       | 60      |       | 275 | 338 |
| 18 - 11                       | 62      | 119   | 241 | 340 |
| 18 - 32                       | 85      | 138   | 222 | 265 |
| 20 - 16                       | 238     | 318   | 333 | 347 |
| 20 - 41                       | 45      | 126   | 225 |     |
| 22 - 21                       | 16      | 135   | 175 | 349 |
| 22 - 55                       | 30      | 142   | 226 | 314 |
| 24 - 61                       | 90      | 180   | 270 | 324 |

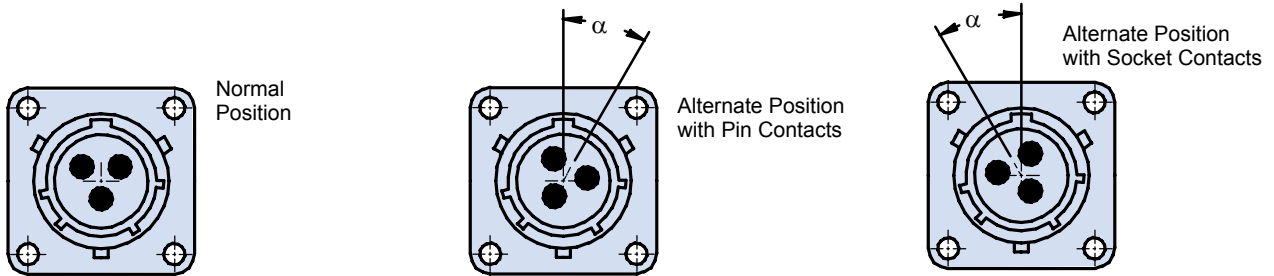

| MATERIALS  |   |
|--|---|
| <b>SHELLS</b><br>Aluminum Alloy<br>IAW QQ-A-591 Shells | <b>INSERTS (Temperature Range)</b><br>High Insulation Synthetic Rubber<br>(Chloroprene): -55°C/+125°C |
| Stainless Steel<br>Coupling Pins                       | <b>CRIMP CONTACTS</b>   |
| Stainless Steel Spring                                 | Copper Alloy with Gold Plating Over Nickel  |

| STANDARD FINISH<br>(For QQ-A-591 Aluminum Shells) |   |
|---|---|
| <b>Requirements</b>                               | <b>Cadmium with Olive<br/>Drab Passivation<br/>IAW QQ-P-416</b> |
| Thermal Shock                                     | -55°C + 125°C   |
| Salt Spray After<br>Thermal Shock                 | 500 hour  |
| Electrical Conductivity                           | Very Good   |
| Abrasion Resistance                               | Very Good   |

See Page 13 for Panel Thickness and Cutout Dimensions

**VG95328 D**  
**Bayonet-Lock**  
**Rear Panel Mount Jam Nut Receptacle**  
**with Backshell**

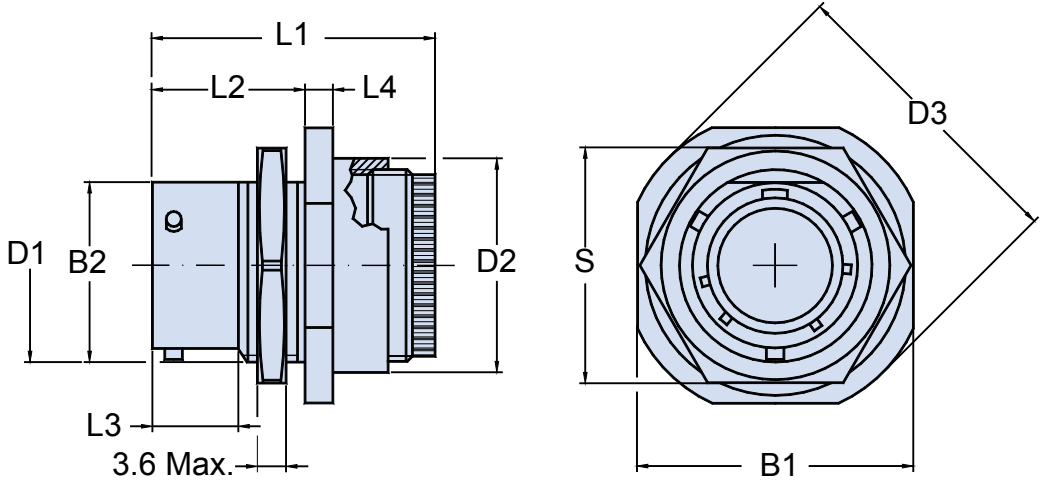
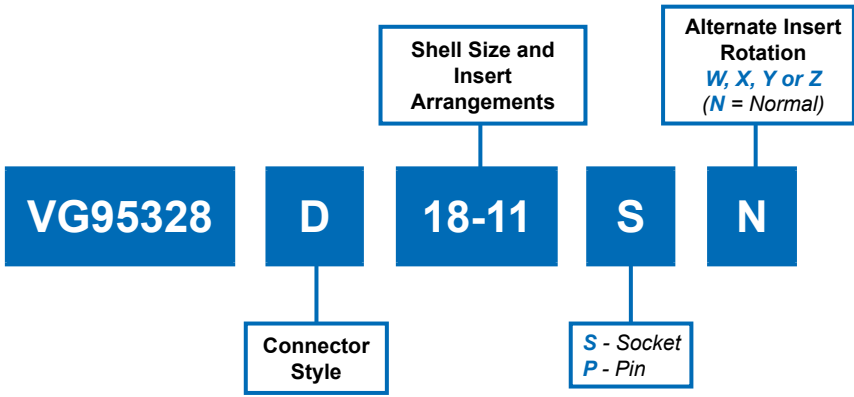

**TABLE I: DIMENSIONS**

| Shell size | B1 Max. | B2 +0 -0.25 | D1               | D2 Min. | D3 +0 -0.8 | L1 Max. | L2 +0.8 -0 | L3 Min. | L4 ±0.5 | S ±0.43 | Maximum Weight in Grams |
|------------|---------|-------------|------------------|---------|------------|---------|------------|---------|---------|---------|-------------------------|
| 8          | 24.3    | 13.46       | 0.5625 - 24 UNEF | 19.0    | 27.3       | 39.3    | 17.5       | 9.75    | 3.0     | 19.05   | 20                      |
| 10         | 27.4    | 16.64       | 0.6875 - 24 UNEF | 22.2    | 30.5       | 39.3    | 17.5       | 9.75    | 3.0     | 22.23   | 21                      |
| 12         | 32.2    | 20.78       | 0.8750 - 20 UNEF | 25.4    | 35.3       | 39.3    | 17.5       | 9.75    | 3.0     | 26.97   | 30                      |
| 14         | 35.4    | 23.93       | 1.0000 - 20 UNEF | 28.5    | 38.5       | 39.3    | 17.5       | 9.75    | 3.0     | 30.18   | 39                      |
| 16         | 38.6    | 27.08       | 1.1250 - 18 UNEF | 31.7    | 41.6       | 39.3    | 17.5       | 9.75    | 3.0     | 33.32   | 49                      |
| 18         | 41.7    | 30.25       | 1.2500 - 18 UNEF | 34.9    | 44.8       | 39.3    | 17.5       | 9.75    | 3.0     | 36.53   | 57                      |
| 20         | 46.5    | 33.43       | 1.3750 - 18 UNEF | 38.8    | 49.6       | 43.4    | 22.3       | 11.32   | 3.8     | 39.67   | 78                      |
| 22         | 49.7    | 36.60       | 1.5000 - 18 UNEF | 42.0    | 52.7       | 43.4    | 22.3       | 11.32   | 3.8     | 42.88   | 97                      |
| 24         | 52.8    | 39.78       | 1.6250 - 18 UNEF | 45.2    | 55.9       | 43.4    | 23.1       | 12.16   | 3.8     | 46.02   | 115                     |

Single Hole Mounting

# VG95328 D Bayonet-Lock Rear Panel Mount Jam Nut Receptacle with Backshell



VG95328  
Connectors

| Contact Arrangements |                  |                   |    |
|----------------------|------------------|-------------------|----|
| Arrangement          | Cl. Isol. Rating | Dim. contact size |    |
|                      |                  | 20                | 16 |
| 8 - 3A               | I                | 3                 |    |
| 10 - 6               | I                | 6                 |    |
| 12 - 3               | II               |                   | 3  |
| 12 - 10              | I                | 10                |    |
| 14 - 5               | II               |                   | 5  |
| 14 - 12              | I                | 8                 | 4  |
| 14 - 15              | I                | 14                | 1  |
| 14 - 19              | I                | 19                |    |
| 16 - 8               | II               |                   | 8  |
| 16 - 23              | I                | 22                | 1  |
| 16 - 26              | I                | 26                |    |
| 18 - 11              | II               |                   | 11 |
| 18 - 32              | I                | 32                |    |
| 20 - 16              | II               |                   | 16 |
| 20 - 41              | I                | 41                |    |
| 22 - 21              | II               |                   | 21 |
| 22 - 55              | I                | 55                |    |
| 24 - 61              | I                | 61                |    |

| Alternate Insert Orientations |         |       |     |     |
|-------------------------------|---------|-------|-----|-----|
| Arrangement                   | Degrees |       |     |     |
|                               | W       | X     | Y   | Z   |
| 8 - 3A                        | 60      | (120) |     |     |
| 10 - 6                        | 90      |       |     |     |
| 12 - 3                        |         |       | 180 |     |
| 12 - 10                       | 60      | 155   | 270 | 295 |
| 14 - 5                        | 40      | 92    | 184 | 273 |
| 14 - 12                       | 43      | 90    |     |     |
| 14 - 15                       | 17      | 110   | 155 | 234 |
| 14 - 19                       | 30      | 165   | 315 |     |
| 16 - 8                        | 54      | 152   | 180 | 331 |
| 16 - 23                       | 158     | 270   |     |     |
| 16 - 26                       | 60      |       | 275 | 338 |
| 18 - 11                       | 62      | 119   | 241 | 340 |
| 18 - 32                       | 85      | 138   | 222 | 265 |
| 20 - 16                       | 238     | 318   | 333 | 347 |
| 20 - 41                       | 45      | 126   | 225 |     |
| 22 - 21                       | 16      | 135   | 175 | 349 |
| 22 - 55                       | 30      | 142   | 226 | 314 |
| 24 - 61                       | 90      | 180   | 270 | 324 |

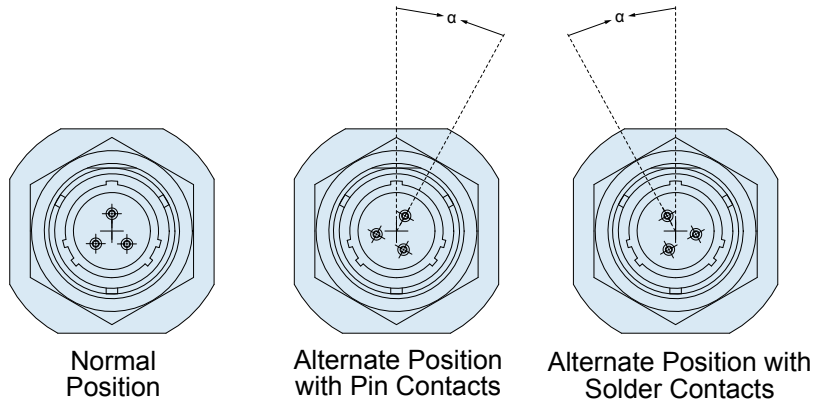

| MATERIALS                             |   |
|---------------------------------------|---|
| SHELLS                                | INSERTS (Temperature Range)                                     |
| Aluminum Alloy<br>IAW QQ-A-591 Shells | High Insulation Synthetic Rubber<br>(Chloroprene): -55°C/+125°C |
| Stainless Steel<br>Coupling Pins      | <b>CRIMP CONTACTS</b>   |
| Stainless Steel Spring                |   |

| STANDARD FINISH<br>(For QQ-A-591 Aluminum Shells) |  |
|---|--|
| Requirements                                      | Cadmium with Olive<br>Drab Passivation<br>IAW QQ-P-416 |
| Thermal Shock                                     | -55°C + 125°C  |
| Salt Spray After<br>Thermal Shock                 | 500 hour   |
| Electrical Conductivity                           | Very Good  |
| Abrasion Resistance                               | Very Good  |

See Page 13 for Panel Thickness and Cutout Dimensions

# VG95328 E Bayonet-Lock Rear Panel Mount Jam Nut Receptacle with Cable Clamp and Bushing

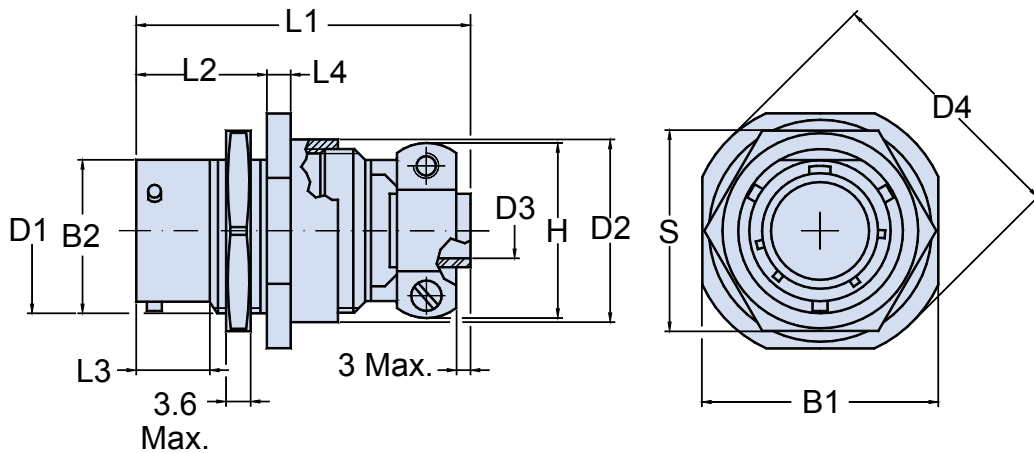
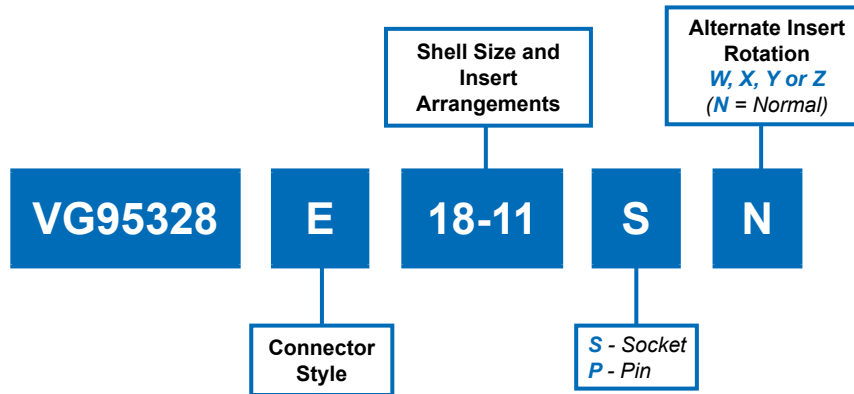

**TABLE I: DIMENSIONS**

| Shell size | B1<br>Max. | B2<br>+0<br>-0.25 | D1               | D2<br>Min. | D3<br>+ 0.3<br>- 0.7 | D4<br>+ 0<br>- 0.8 | L1<br>Max. | L2<br>+ 0.8<br>- 0 | L3<br>Min. | L4<br>± 0.15 | S<br>± 0.43 | Maximum<br>Weight in<br>Grams |
|------------|------------|-------------------|------------------|------------|----------------------|--------------------|------------|--------------------|------------|--------------|-------------|-------------------------------|
| 8          | 24.3       | 13.46             | 0.5625 - 24 UNEF | 19.0       | 3.2                  | 27.3               | 61.5       | 17.5               | 9.75       | 3.0          | 19.05       | 25                            |
| 10         | 27.4       | 16.64             | 0.6875 - 24 UNEF | 22.2       | 4.8                  | 30.5               | 61.5       | 17.5               | 9.75       | 3.0          | 22.23       | 25                            |
| 12         | 32.2       | 20.78             | 0.8750 - 20 UNEF | 25.4       | 7.9                  | 35.3               | 61.5       | 17.5               | 9.75       | 3.0          | 26.97       | 37                            |
| 14         | 35.4       | 23.93             | 1.0000 - 20 UNEF | 28.5       | 9.5                  | 38.5               | 61.5       | 17.5               | 9.75       | 3.0          | 30.18       | 50                            |
| 16         | 38.6       | 27.08             | 1.1250 - 18 UNEF | 31.7       | 12.7                 | 41.6               | 64.4       | 17.5               | 9.75       | 3.0          | 33.32       | 63                            |
| 18         | 41.7       | 30.25             | 1.2500 - 18 UNEF | 34.9       | 15.9                 | 44.8               | 64.4       | 17.5               | 9.75       | 3.0          | 36.53       | 74                            |
| 20         | 46.5       | 33.43             | 1.3750 - 18 UNEF | 38.8       | 15.9                 | 49.6               | 71.1       | 22.3               | 11.32      | 3.8          | 39.67       | 97                            |
| 22         | 49.7       | 36.60             | 1.5000 - 18 UNEF | 42.0       | 19.1                 | 52.7               | 71.1       | 22.3               | 11.32      | 3.8          | 42.88       | 117                           |
| 24         | 52.8       | 39.78             | 1.6250 - 18 UNEF | 45.2       | 20.3                 | 55.9               | 73.6       | 23.1               | 12.16      | 3.8          | 46.02       | 137                           |

### Single Hole Mounting



# VG95328 E Bayonet-Lock Rear Panel Mount Jam Nut Receptacle with Cable Clamp and Bushing



VG95328  
Connectors

| Contact Arrangements |                  |                   |    |
|----------------------|------------------|-------------------|----|
| Arrangement          | Cl. Isol. Rating | Dim. contact size |    |
|                      |                  | 20                | 16 |
| 8 - 3A               | I                | 3                 |    |
| 10 - 6               | I                | 6                 |    |
| 12 - 3               | II               |                   | 3  |
| 12 - 10              | I                | 10                |    |
| 14 - 5               | II               |                   | 5  |
| 14 - 12              | I                | 8                 | 4  |
| 14 - 15              | I                | 14                | 1  |
| 14 - 19              | I                | 19                |    |
| 16 - 8               | II               |                   | 8  |
| 16 - 23              | I                | 22                | 1  |
| 16 - 26              | I                | 26                |    |
| 18 - 11              | II               |                   | 11 |
| 18 - 32              | I                | 32                |    |
| 20 - 16              | II               |                   | 16 |
| 20 - 41              | I                | 41                |    |
| 22 - 21              | II               |                   | 21 |
| 22 - 55              | I                | 55                |    |
| 24 - 61              | I                | 61                |    |

| Alternate Insert Orientations |         |       |     |     |
|-------------------------------|---------|-------|-----|-----|
| Arrangement                   | Degrees |       |     |     |
|                               | W       | X     | Y   | Z   |
| 8 - 3A                        | 60      | (120) |     |     |
| 10 - 6                        | 90      |       |     |     |
| 12 - 3                        |         |       | 180 |     |
| 12 - 10                       | 60      | 155   | 270 | 295 |
| 14 - 5                        | 40      | 92    | 184 | 273 |
| 14 - 12                       | 43      | 90    |     |     |
| 14 - 15                       | 17      | 110   | 155 | 234 |
| 14 - 19                       | 30      | 165   | 315 |     |
| 16 - 8                        | 54      | 152   | 180 | 331 |
| 16 - 23                       | 158     | 270   |     |     |
| 16 - 26                       | 60      |       | 275 | 338 |
| 18 - 11                       | 62      | 119   | 241 | 340 |
| 18 - 32                       | 85      | 138   | 222 | 265 |
| 20 - 16                       | 238     | 318   | 333 | 347 |
| 20 - 41                       | 45      | 126   | 225 |     |
| 22 - 21                       | 16      | 135   | 175 | 349 |
| 22 - 55                       | 30      | 142   | 226 | 314 |
| 24 - 61                       | 90      | 180   | 270 | 324 |

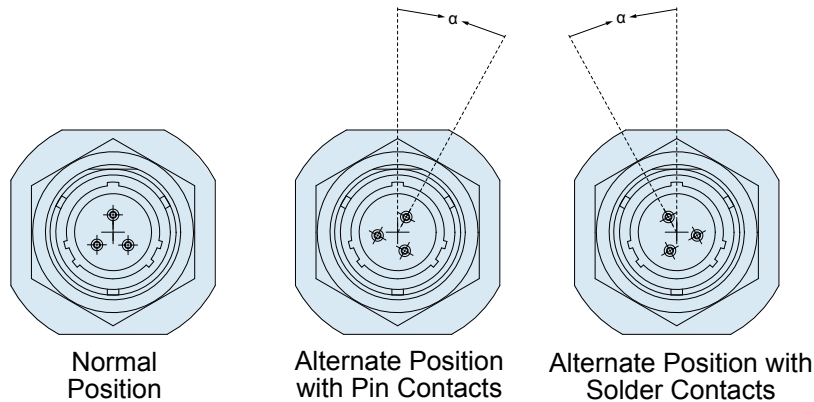

| MATERIALS                             |   |
|---------------------------------------|---|
| <b>SHELLS</b>                         | <b>INSERTS (Temperature Range)</b>                              |
| Aluminum Alloy<br>IAW QQ-A-591 Shells | High Insulation Synthetic Rubber<br>(Chloroprene): -55°C/+125°C |
| Stainless Steel<br>Coupling Pins      | <b>CRIMP CONTACTS</b>   |
| Stainless Steel Spring                | Copper Alloy with Gold Plating Over Nickel                      |

| STANDARD FINISH<br>(For QQ-A-591 Aluminum Shells) |   |
|---|---|
| <b>Requirements</b>                               | <b>Cadmium with Olive Drab Passivation<br/>IAW QQ-P-416</b> |
| Thermal Shock                                     | -55°C + 125°C   |
| Salt Spray After Thermal Shock                    | 500 hour  |
| Electrical Conductivity                           | Very Good   |
| Abrasion Resistance                               | Very Good   |

See Page 13 for Panel Thickness and Cutout Dimensions

**VG95328 F**  
**Bayonet-Lock**  
**Rear Panel Mount Hermetic Jam Nut**  
**Receptacle with Pin Solder Contacts**

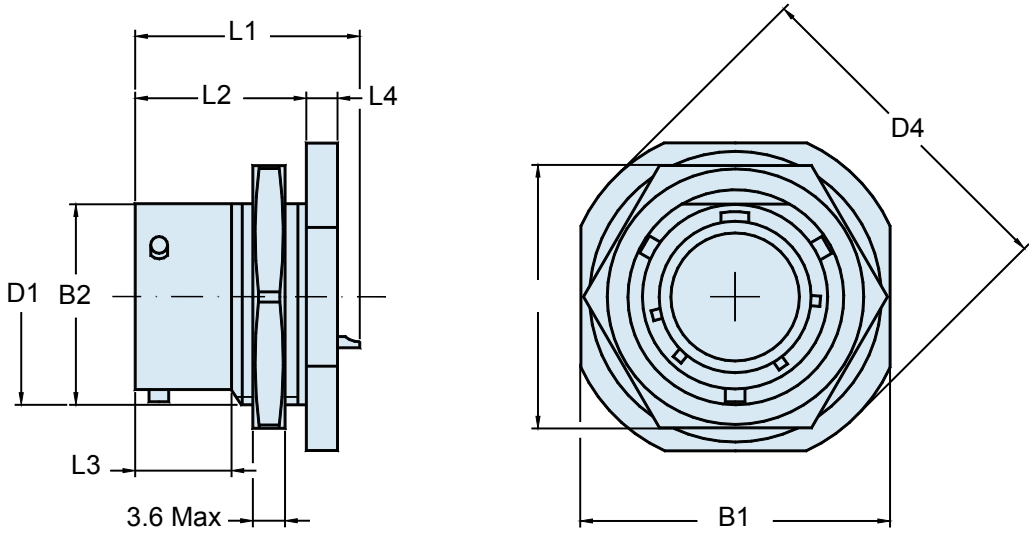
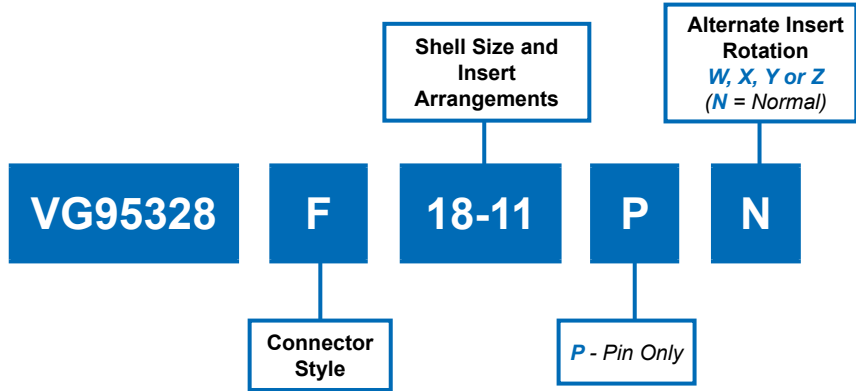

| Shell Size | B1 Max | B2 +0 -0.25 | D1               | D4 +0 -0.8 | L1 Max | L2 +0.8 -0 | L3 Min | L4 ± 0.15 | S ± 0.43 | Max Weight (g) |
|------------|--------|-------------|------------------|------------|--------|------------|--------|-----------|----------|----------------|
| 8          | 24.3   | 13.46       | 0.5626 - 24 UNEF | 27.3       | 26.0   | 17.5       | 9.75   | 3.0       | 19.05    | 20             |
| 10         | 27.4   | 16.64       | 0.6875 - 24 UNEF | 30.5       | 26.0   | 17.5       | 9.75   | 3.0       | 22.23    | 26             |
| 12         | 32.2   | 20.78       | 0.8750 - 20 UNEF | 35.3       | 26.0   | 17.5       | 9.75   | 3.0       | 26.97    | 40             |
| 14         | 35.4   | 23.93       | 1.0000 - 20 UNEF | 38.5       | 26.0   | 17.5       | 9.75   | 3.0       | 30.18    | 46             |
| 16         | 38.6   | 27.08       | 1.1250 - 18 UNEF | 41.6       | 26.0   | 17.5       | 9.75   | 3.0       | 33.32    | 56             |
| 18         | 41.7   | 30.25       | 1.2500 - 18 UNEF | 44.8       | 26.0   | 17.5       | 9.75   | 3.0       | 36.53    | 68             |
| 20         | 46.5   | 33.43       | 1.3750 - 18 UNEF | 49.6       | 32.0   | 22.3       | 22.3   | 3.8       | 39.67    | 90             |
| 22         | 49.7   | 36.60       | 1.5000 - 18 UNEF | 52.7       | 32.0   | 22.3       | 22.3   | 3.8       | 42.88    | 105            |
| 24         | 52.8   | 39.78       | 1.6250 - 18 UNEF | 55.9       | 32.0   | 23.1       | 23.1   | 3.8       | 46.02    | 115            |

Single Hole Mounting

# VG95328 F Bayonet-Lock Rear Panel Mount Hermetic Jam Nut Receptacle with Pin Solder Contacts



VG95328  
Connectors

| Contact Arrangements |                  |                   |    |
|----------------------|------------------|-------------------|----|
| Arrangement          | Cl. Isol. Rating | Dim. contact size |    |
|                      |                  | 20                | 16 |
| 8 - 3A               | I                | 3                 |    |
| 10 - 6               | I                | 6                 |    |
| 12 - 3               | II               |                   | 3  |
| 12 - 10              | I                | 10                |    |
| 14 - 5               | II               |                   | 5  |
| 14 - 12              | I                | 8                 | 4  |
| 14 - 15              | I                | 14                | 1  |
| 14 - 19              | I                | 19                |    |
| 16 - 8               | II               |                   | 8  |
| 16 - 23              | I                | 22                | 1  |
| 16 - 26              | I                | 26                |    |
| 18 - 11              | II               |                   | 11 |
| 18 - 32              | I                | 32                |    |
| 20 - 16              | II               |                   | 16 |
| 20 - 41              | I                | 41                |    |
| 22 - 21              | II               |                   | 21 |
| 22 - 55              | I                | 55                |    |
| 24 - 61              | I                | 61                |    |

| Alternate Insert Orientations |         |       |     |     |
|-------------------------------|---------|-------|-----|-----|
| Arrangement                   | Degrees |       |     |     |
|                               | W       | X     | Y   | Z   |
| 8 - 3A                        | 60      | (120) |     |     |
| 10 - 6                        | 90      |       |     |     |
| 12 - 3                        |         |       | 180 |     |
| 12 - 10                       | 60      | 155   | 270 | 295 |
| 14 - 5                        | 40      | 92    | 184 | 273 |
| 14 - 12                       | 43      | 90    |     |     |
| 14 - 15                       | 17      | 110   | 155 | 234 |
| 14 - 19                       | 30      | 165   | 315 |     |
| 16 - 8                        | 54      | 152   | 180 | 331 |
| 16 - 23                       | 158     | 270   |     |     |
| 16 - 26                       | 60      |       | 275 | 338 |
| 18 - 11                       | 62      | 119   | 241 | 340 |
| 18 - 32                       | 85      | 138   | 222 | 265 |
| 20 - 16                       | 238     | 318   | 333 | 347 |
| 20 - 41                       | 45      | 126   | 225 |     |
| 22 - 21                       | 16      | 135   | 175 | 349 |
| 22 - 55                       | 30      | 142   | 226 | 314 |
| 24 - 61                       | 90      | 180   | 270 | 324 |

**Class F, G and H hermetic versions not qualified to VG95328. Please consult factory for Glenair commercial equivalent MIL-DTL-26482 and VG95328 type hermetic connectors.**

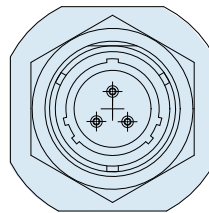

Normal Position

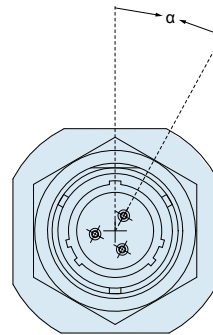

Alternate Position with Pin Contacts

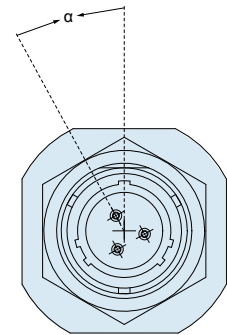

Alternate Position with Solder Contacts

| MATERIALS                             |  |
|---------------------------------------|--|
| SHELLS                                | INSERTS                                    |
| Aluminum Alloy<br>IAW QQ-A-591 Shells | Glass                                      |
| Stainless Steel<br>Coupling Pins      | <b>SOLDER CONTACTS</b>                     |
| Stainless Steel Spring                | Copper Alloy with Gold Plating Over Nickel |

| STANDARD FINISH<br>(For QQ-A-591 Aluminum Shells) |  |
|---|--|
| Requirements                                      | Cadmium with Olive<br>Drab Passivation<br>IAW QQ-P-416 |
| Thermal Shock                                     | -55°C + 125°C  |
| Salt Spray After<br>Thermal Shock                 | 500 hour   |
| Electrical Conductivity                           | Very Good  |
| Abrasion Resistance                               | Very Good  |

See Page 13 for Panel Thickness and Cutout Dimensions

**VG95328 G**  
**Bayonet-Lock**  
**Solder Mount Hermetic Receptacle**  
**with Pin Solder Contacts**

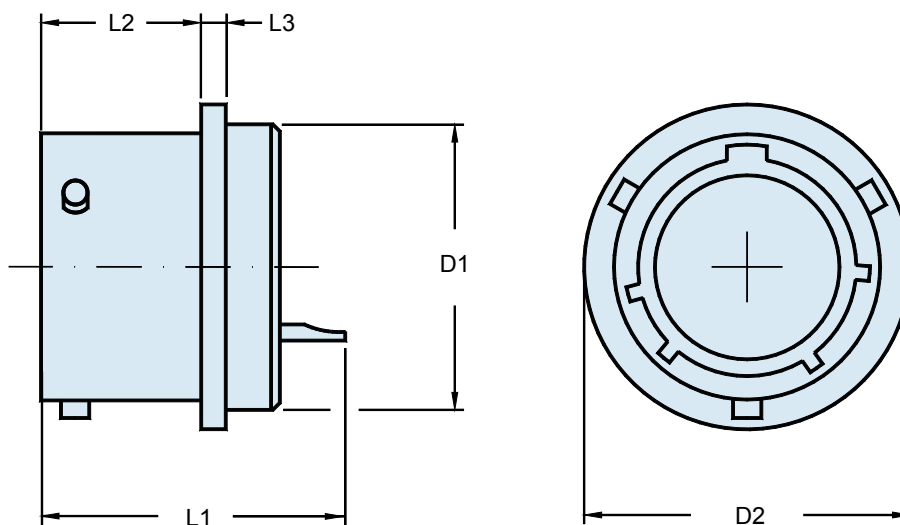
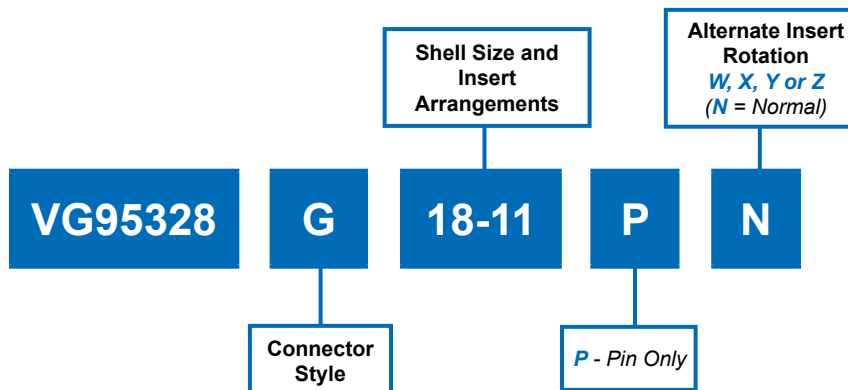

| Shell Size | D1<br>+0.02<br>-0.13 | D2<br>±0.4 | L1<br>Max | L2<br>+0.8<br>-0 | L3<br>+0.4<br>-0.13 | Max Weight (g) |
|------------|----------------------|------------|-----------|------------------|---------------------|----------------|
| 8          | 14.27                | 15.9       | 21.0      | 10.5             | 0.8                 | 8              |
| 10         | 17.07                | 19.1       | 21.0      | 10.5             | 0.8                 | 13             |
| 12         | 19.84                | 21.4       | 21.0      | 10.5             | 0.8                 | 20             |
| 14         | 23.01                | 24.6       | 21.0      | 10.5             | 0.8                 | 23             |
| 16         | 26.19                | 27.8       | 21.0      | 10.5             | 0.8                 | 26             |
| 18         | 29.36                | 30.9       | 21.0      | 10.5             | 0.8                 | 32             |
| 20         | 31.75                | 33.3       | 22.6      | 12.1             | 0.8                 | 44             |
| 22         | 34.92                | 36.5       | 23.4      | 12.1             | 0.8                 | 56             |
| 24         | 38.10                | 39.7       | 23.4      | 12.9             | 0.8                 | 60             |

Single Hole Mounting

# VG95328 G Bayonet-Lock Solder Mount Hermetic Receptacle with Pin Solder Contacts



VG95328  
Connectors

| Contact Arrangements |                  |                   |    |
|----------------------|------------------|-------------------|----|
| Arrangement          | Cl. Isol. Rating | Dim. contact size |    |
|                      |                  | 20                | 16 |
| 8 - 3A               | I                | 3                 |    |
| 10 - 6               | I                | 6                 |    |
| 12 - 3               | II               |                   | 3  |
| 12 - 10              | I                | 10                |    |
| 14 - 5               | II               |                   | 5  |
| 14 - 12              | I                | 8                 | 4  |
| 14 - 15              | I                | 14                | 1  |
| 14 - 19              | I                | 19                |    |
| 16 - 8               | II               |                   | 8  |
| 16 - 23              | I                | 22                | 1  |
| 16 - 26              | I                | 26                |    |
| 18 - 11              | II               |                   | 11 |
| 18 - 32              | I                | 32                |    |
| 20 - 16              | II               |                   | 16 |
| 20 - 41              | I                | 41                |    |
| 22 - 21              | II               |                   | 21 |
| 22 - 55              | I                | 55                |    |
| 24 - 61              | I                | 61                |    |

| Alternate Insert Orientations |         |       |     |     |
|-------------------------------|---------|-------|-----|-----|
| Arrangement                   | Degrees |       |     |     |
|                               | W       | X     | Y   | Z   |
| 8 - 3A                        | 60      | (120) |     |     |
| 10 - 6                        | 90      |       |     |     |
| 12 - 3                        |         |       | 180 |     |
| 12 - 10                       | 60      | 155   | 270 | 295 |
| 14 - 5                        | 40      | 92    | 184 | 273 |
| 14 - 12                       | 43      | 90    |     |     |
| 14 - 15                       | 17      | 110   | 155 | 234 |
| 14 - 19                       | 30      | 165   | 315 |     |
| 16 - 8                        | 54      | 152   | 180 | 331 |
| 16 - 23                       | 158     | 270   |     |     |
| 16 - 26                       | 60      |       | 275 | 338 |
| 18 - 11                       | 62      | 119   | 241 | 340 |
| 18 - 32                       | 85      | 138   | 222 | 265 |
| 20 - 16                       | 238     | 318   | 333 | 347 |
| 20 - 41                       | 45      | 126   | 225 |     |
| 22 - 21                       | 16      | 135   | 175 | 349 |
| 22 - 55                       | 30      | 142   | 226 | 314 |
| 24 - 61                       | 90      | 180   | 270 | 324 |

**Class F, G and H hermetic versions not qualified to VG95328. Please consult factory for Glenair commercial equivalent MIL-DTL-26482 and VG95328 type hermetic connectors.**

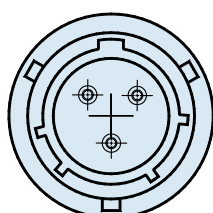

Normal Position

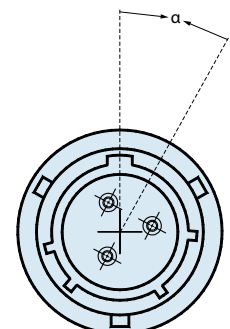

Alternate Position with Pin Contacts

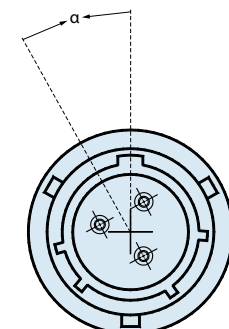

Alternate Position with Solder Contacts

| MATERIALS                             |  |
|---------------------------------------|--|
| SHELLS                                | INSERTS                                    |
| Aluminum Alloy<br>IAW QQ-A-591 Shells | Glass                                      |
| Stainless Steel<br>Coupling Pins      | <b>SOLDER CONTACTS</b>                     |
| Stainless Steel Spring                | Copper Alloy with Gold Plating Over Nickel |

| STANDARD FINISH<br>(For QQ-A-591 Aluminum Shells) |   |
|---|---|
| Requirements                                      | Cadmium with Olive Drab Passivation<br>IAW QQ-P-416 |
| Thermal Shock                                     | -55°C + 125°C                                       |
| Salt Spray After Thermal Shock                    | 500 hour  |
| Electrical Conductivity                           | Very Good   |
| Abrasion Resistance                               | Very Good   |

Consult Factory for Panel Thickness and Cutout Dimensions

**VG95328 H**  
**Bayonet-Lock**  
**Front Panel Mount Square Flange Hermetic Receptacle**  
**with Solder Contacts**

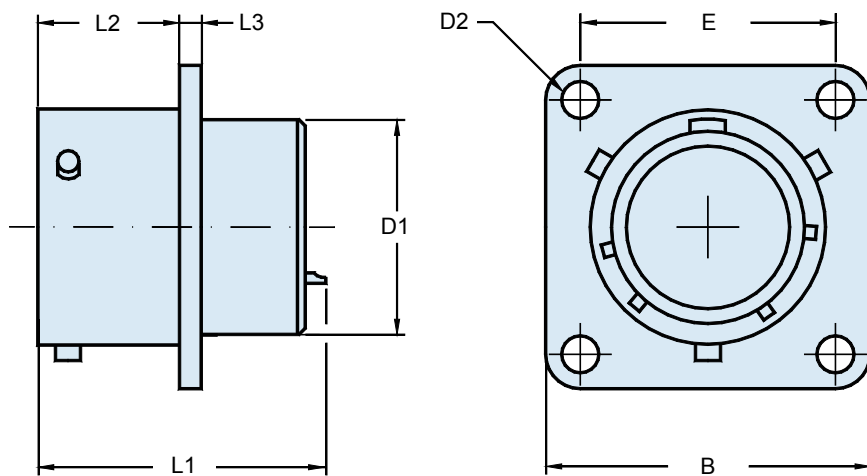
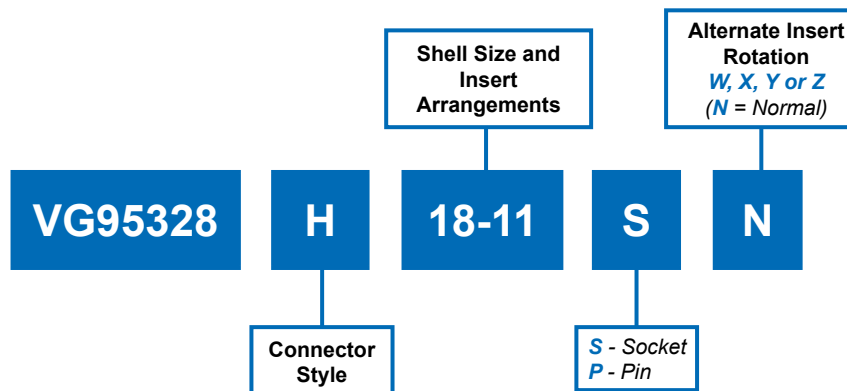

| Shell Size | B Max | D1 +0.8 -0.6 | D2 Min | E ±0.15 | L1 Max | L2 +0.8 -0 | L3 Max | Max Weight (g) |
|------------|-------|--------------|--------|---------|--------|------------|--------|----------------|
| 8          | 21.03 | 11.2         | 2.9    | 15.08   | 24.9   | 10.94      | 2.0    | 7              |
| 10         | 24.23 | 14.3         | 2.9    | 18.26   | 24.9   | 10.94      | 2.0    | 10             |
| 12         | 26.59 | 17.5         | 2.9    | 20.62   | 24.9   | 10.94      | 2.0    | 20             |
| 14         | 28.98 | 20.7         | 2.9    | 23.01   | 24.9   | 10.94      | 2.0    | 20             |
| 16         | 31.34 | 23.9         | 2.9    | 24.61   | 24.9   | 10.94      | 2.0    | 28             |
| 18         | 33.73 | 27.0         | 2.9    | 26.97   | 24.9   | 10.94      | 2.0    | 34             |
| 20         | 36.90 | 30.2         | 2.9    | 29.36   | 30.4   | 14.12      | 2.8    | 43             |
| 22         | 40.08 | 33.4         | 2.9    | 31.75   | 30.4   | 14.12      | 2.8    | 55             |
| 24         | 43.25 | 36.6         | 3.6    | 34.92   | 30.4   | 14.96      | 2.8    | 70             |

\* Through Mounting Holes

# VG95328 H Bayonet-Lock Front Panel Mount Square Flange Hermetic Receptacle with Solder Contacts



VG95328  
Connectors

| Contact Arrangements |                  |                   |    |
|----------------------|------------------|-------------------|----|
| Arrangement          | Cl. Isol. Rating | Dim. contact size |    |
|                      |                  | 20                | 16 |
| 8 - 3A               | I                | 3                 |    |
| 10 - 6               | I                | 6                 |    |
| 12 - 3               | II               |                   | 3  |
| 12 - 10              | I                | 10                |    |
| 14 - 5               | II               |                   | 5  |
| 14 - 12              | I                | 8                 | 4  |
| 14 - 15              | I                | 14                | 1  |
| 14 - 19              | I                | 19                |    |
| 16 - 8               | II               |                   | 8  |
| 16 - 23              | I                | 22                | 1  |
| 16 - 26              | I                | 26                |    |
| 18 - 11              | II               |                   | 11 |
| 18 - 32              | I                | 32                |    |
| 20 - 16              | II               |                   | 16 |
| 20 - 41              | I                | 41                |    |
| 22 - 21              | II               |                   | 21 |
| 22 - 55              | I                | 55                |    |
| 24 - 61              | I                | 61                |    |

| Alternate Insert Orientations |         |       |     |     |
|-------------------------------|---------|-------|-----|-----|
| Arrangement                   | Degrees |       |     |     |
|                               | W       | X     | Y   | Z   |
| 8 - 3A                        | 60      | (120) |     |     |
| 10 - 6                        | 90      |       |     |     |
| 12 - 3                        |         |       | 180 |     |
| 12 - 10                       | 60      | 155   | 270 | 295 |
| 14 - 5                        | 40      | 92    | 184 | 273 |
| 14 - 12                       | 43      | 90    |     |     |
| 14 - 15                       | 17      | 110   | 155 | 234 |
| 14 - 19                       | 30      | 165   | 315 |     |
| 16 - 8                        | 54      | 152   | 180 | 331 |
| 16 - 23                       | 158     | 270   |     |     |
| 16 - 26                       | 60      |       | 275 | 338 |
| 18 - 11                       | 62      | 119   | 241 | 340 |
| 18 - 32                       | 85      | 138   | 222 | 265 |
| 20 - 16                       | 238     | 318   | 333 | 347 |
| 20 - 41                       | 45      | 126   | 225 |     |
| 22 - 21                       | 16      | 135   | 175 | 349 |
| 22 - 55                       | 30      | 142   | 226 | 314 |
| 24 - 61                       | 90      | 180   | 270 | 324 |

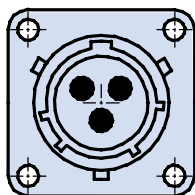

Normal Position

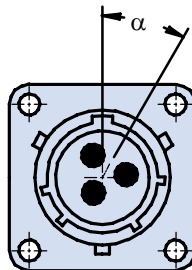

Alternate Position with Pin Contacts

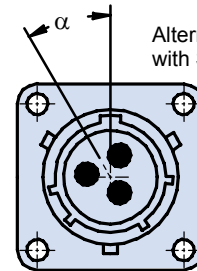

Alternate Position with Socket Contacts

**Class F, G and H hermetic versions not qualified to VG95328.  
Please consult factory for Glenair commercial equivalent  
MIL-DTL-26482 and VG95328 type hermetic connectors.**

| MATERIALS                             |  |
|---------------------------------------|--|
| SHELLS                                | INSERTS                                    |
| Aluminum Alloy<br>IAW QQ-A-591 Shells | Glass                                      |
| Stainless Steel<br>Coupling Pins      | <b>SOLDER CONTACTS</b>                     |
| Stainless Steel Spring                | Copper Alloy with Gold Plating Over Nickel |

| STANDARD FINISH<br>(For QQ-A-591 Aluminum Shells) |  |
|---|--|
| Requirements                                      | Cadmium with Olive<br>Drab Passivation<br>IAW QQ-P-416 |
| Thermal Shock                                     | -55°C + 125°C  |
| Salt Spray After<br>Thermal Shock                 | 500 hour   |
| Electical Conductivity                            | Very Good  |
| Abrasion Resistance                               | Very Good  |

See Page 13 for Panel Thickness and Cutout Dimensions

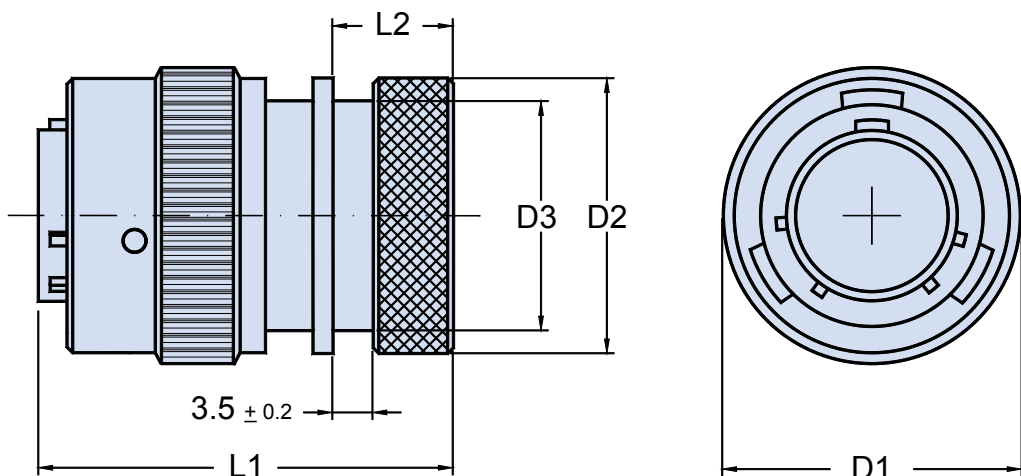
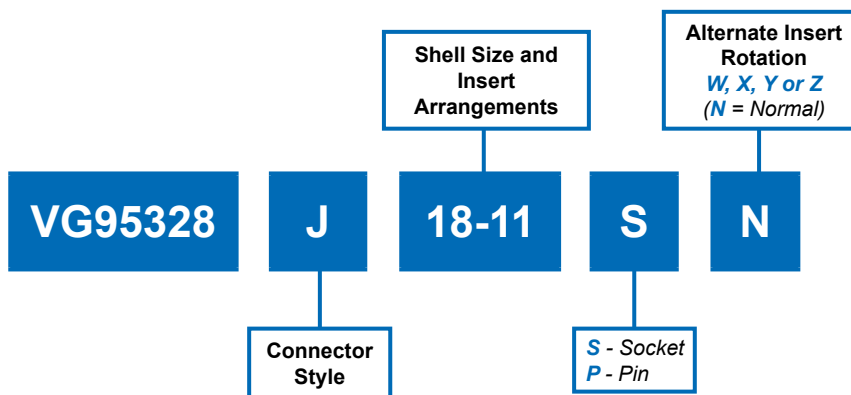

| TABLE I: DIMENSIONS |         |            |            |         |          |                         |
|---------------------|---------|------------|------------|---------|----------|-------------------------|
| Shell size          | D1 Max. | D2 +0 -0.5 | D3 +0 -0.5 | L1 Max. | L2 ± 0.5 | Maximum Weight in Grams |
| 8                   | 19.8    | 15.6       | 13.3       | 39      | 12.2     | 14                      |
| 10                  | 23.5    | 18.4       | 16.1       | 39      | 12.2     | 16                      |
| 12                  | 26.5    | 23.7       | 21.4       | 39      | 12.2     | 23                      |
| 14                  | 30.0    | 24.5       | 22.2       | 39      | 12.2     | 30                      |
| 16                  | 33.1    | 29.8       | 26.2       | 39      | 14.5     | 43                      |
| 18                  | 35.3    | 32.0       | 28.5       | 39      | 14.5     | 46                      |
| 20                  | 38.8    | 36.1       | 32.5       | 44      | 15.8     | 63                      |
| 22                  | 42.0    | 38.5       | 34.8       | 44      | 15.8     | 78                      |
| 24                  | 45.1    | 41.6       | 37.9       | 44      | 14.9     | 84                      |



# VG95328 J Bayonet-Lock Straight Plug Connector with Shrinkboot Backshell



VG95328  
Connectors

| Contact Arrangements |                  |                   |    |
|----------------------|------------------|-------------------|----|
| Arrangement          | Cl. Isol. Rating | Dim. contact size |    |
|                      |                  | 20                | 16 |
| 8 - 3A               | I                | 3                 |    |
| 10 - 6               | I                | 6                 |    |
| 12 - 3               | II               |                   | 3  |
| 12 - 10              | I                | 10                |    |
| 14 - 5               | II               |                   | 5  |
| 14 - 12              | I                | 8                 | 4  |
| 14 - 15              | I                | 14                | 1  |
| 14 - 19              | I                | 19                |    |
| 16 - 8               | II               |                   | 8  |
| 16 - 23              | I                | 22                | 1  |
| 16 - 26              | I                | 26                |    |
| 18 - 11              | II               |                   | 11 |
| 18 - 32              | I                | 32                |    |
| 20 - 16              | II               |                   | 16 |
| 20 - 41              | I                | 41                |    |
| 22 - 21              | II               |                   | 21 |
| 22 - 55              | I                | 55                |    |
| 24 - 61              | I                | 61                |    |

| Alternate Insert Orientations |         |       |     |     |
|-------------------------------|---------|-------|-----|-----|
| Arrangement                   | Degrees |       |     |     |
|                               | W       | X     | Y   | Z   |
| 8 - 3A                        | 60      | (120) |     |     |
| 10 - 6                        | 90      |       |     |     |
| 12 - 3                        |         |       | 180 |     |
| 12 - 10                       | 60      | 155   | 270 | 295 |
| 14 - 5                        | 40      | 92    | 184 | 273 |
| 14 - 12                       | 43      | 90    |     |     |
| 14 - 15                       | 17      | 110   | 155 | 234 |
| 14 - 19                       | 30      | 165   | 315 |     |
| 16 - 8                        | 54      | 152   | 180 | 331 |
| 16 - 23                       | 158     | 270   |     |     |
| 16 - 26                       | 60      |       | 275 | 338 |
| 18 - 11                       | 62      | 119   | 241 | 340 |
| 18 - 32                       | 85      | 138   | 222 | 265 |
| 20 - 16                       | 238     | 318   | 333 | 347 |
| 20 - 41                       | 45      | 126   | 225 |     |
| 22 - 21                       | 16      | 135   | 175 | 349 |
| 22 - 55                       | 30      | 142   | 226 | 314 |
| 24 - 61                       | 90      | 180   | 270 | 324 |

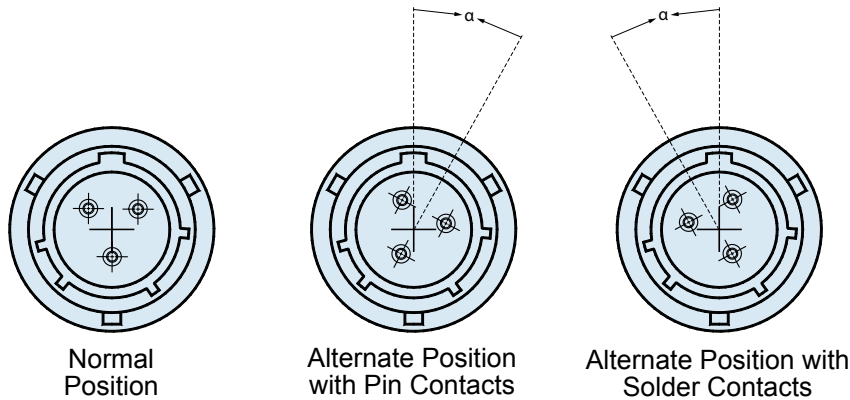

| MATERIALS                             |   |
|---------------------------------------|---|
| <b>SHELLS</b>                         | <b>INSERTS (Temperature Range)</b>                              |
| Aluminum Alloy<br>IAW QQ-A-591 Shells | High Insulation Synthetic Rubber<br>(Chloroprene): -55°C/+125°C |
| Stainless Steel<br>Coupling Pins      | <b>CRIMP CONTACTS</b>   |
| Stainless Steel Spring                | Copper Alloy with Gold Plating Over Nickel                      |

| STANDARD FINISH<br>(For QQ-A-591 Aluminum Shells) |   |
|---|---|
| <b>Requirements</b>                               | <b>Cadmium with Olive Drab Passivation IAW QQ-P-416</b> |
| Thermal Shock                                     | -55°C + 125°C   |
| Salt Spray After Thermal Shock                    | 500 hour  |
| Electrical Conductivity                           | Very Good   |
| Abrasion Resistance                               | Very Good   |

**VG95328 K**  
**Bayonet-Lock**  
**Straight Plug Connector**  
**with Cable Clamp and Bushing**

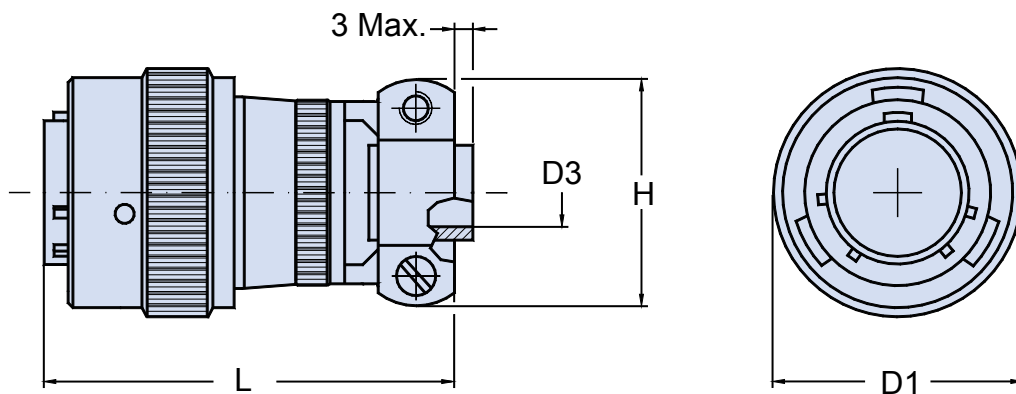
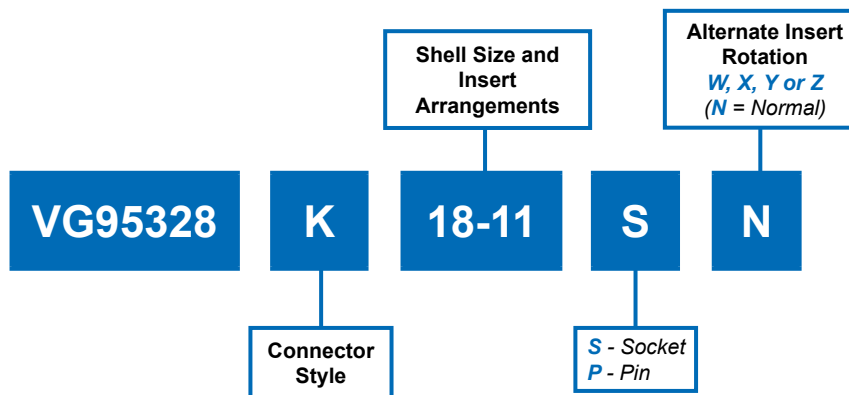

| TABLE I: DIMENSIONS |         |                |        |        |                         |
|---------------------|---------|----------------|--------|--------|-------------------------|
| Shell size          | D1 Max. | D3 + 0.3 - 0.7 | H Max. | L Max. | Maximum Weight in Grams |
| 8                   | 19.8    | 3.2            | 21.1   | 61.3   | 22                      |
| 10                  | 23.5    | 4.8            | 22.7   | 61.3   | 24                      |
| 12                  | 26.5    | 7.9            | 25.9   | 61.3   | 30                      |
| 14                  | 30.0    | 9.5            | 29.0   | 61.3   | 40                      |
| 16                  | 33.1    | 12.7           | 30.6   | 64.3   | 47                      |
| 18                  | 35.3    | 15.9           | 37.4   | 64.3   | 62                      |
| 20                  | 38.8    | 15.9           | 37.4   | 70.0   | 79                      |
| 22                  | 42.0    | 19.1           | 42.1   | 70.0   | 97                      |
| 24                  | 45.1    | 20.3           | 44.5   | 71.9   | 104                     |

# VG95328 K Bayonet-Lock Straight Plug Connector with Cable Clamp and Bushing



VG95328  
Connectors

| Contact Arrangements |                  |                   |    |
|----------------------|------------------|-------------------|----|
| Arrangement          | Cl. Isol. Rating | Dim. contact size |    |
|                      |                  | 20                | 16 |
| 8 - 3A               | I                | 3                 |    |
| 10 - 6               | I                | 6                 |    |
| 12 - 3               | II               |                   | 3  |
| 12 - 10              | I                | 10                |    |
| 14 - 5               | II               |                   | 5  |
| 14 - 12              | I                | 8                 | 4  |
| 14 - 15              | I                | 14                | 1  |
| 14 - 19              | I                | 19                |    |
| 16 - 8               | II               |                   | 8  |
| 16 - 23              | I                | 22                | 1  |
| 16 - 26              | I                | 26                |    |
| 18 - 11              | II               |                   | 11 |
| 18 - 32              | I                | 32                |    |
| 20 - 16              | II               |                   | 16 |
| 20 - 41              | I                | 41                |    |
| 22 - 21              | II               |                   | 21 |
| 22 - 55              | I                | 55                |    |
| 24 - 61              | I                | 61                |    |

| Alternate Insert Orientations |         |       |     |     |
|-------------------------------|---------|-------|-----|-----|
| Arrangement                   | Degrees |       |     |     |
|                               | W       | X     | Y   | Z   |
| 8 - 3A                        | 60      | (120) |     |     |
| 10 - 6                        | 90      |       |     |     |
| 12 - 3                        |         |       | 180 |     |
| 12 - 10                       | 60      | 155   | 270 | 295 |
| 14 - 5                        | 40      | 92    | 184 | 273 |
| 14 - 12                       | 43      | 90    |     |     |
| 14 - 15                       | 17      | 110   | 155 | 234 |
| 14 - 19                       | 30      | 165   | 315 |     |
| 16 - 8                        | 54      | 152   | 180 | 331 |
| 16 - 23                       | 158     | 270   |     |     |
| 16 - 26                       | 60      |       | 275 | 338 |
| 18 - 11                       | 62      | 119   | 241 | 340 |
| 18 - 32                       | 85      | 138   | 222 | 265 |
| 20 - 16                       | 238     | 318   | 333 | 347 |
| 20 - 41                       | 45      | 126   | 225 |     |
| 22 - 21                       | 16      | 135   | 175 | 349 |
| 22 - 55                       | 30      | 142   | 226 | 314 |
| 24 - 61                       | 90      | 180   | 270 | 324 |

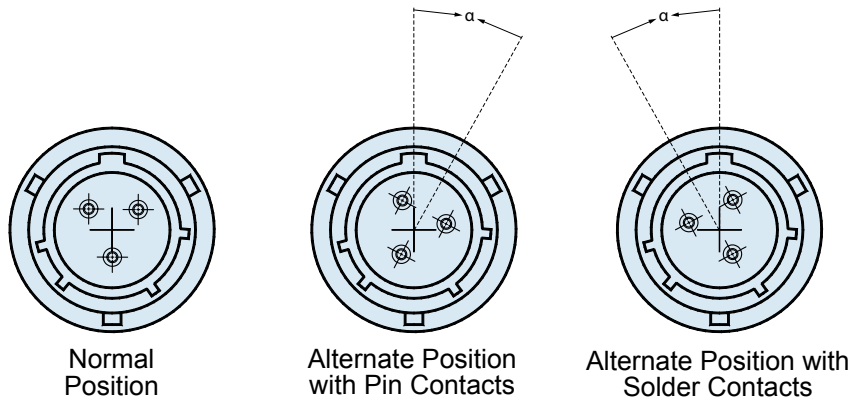

| MATERIALS                             |   |
|---------------------------------------|---|
| <b>SHELLS</b>                         | <b>INSERTS (Temperature Range)</b>                              |
| Aluminum Alloy<br>IAW QQ-A-591 Shells | High Insulation Synthetic Rubber<br>(Chloroprene): -55°C/+125°C |
| Stainless Steel<br>Coupling Pins      | <b>CRIMP CONTACTS</b>   |
| Stainless Steel Spring                | Copper Alloy with Gold Plating Over Nickel                      |

| STANDARD FINISH<br>(For QQ-A-591 Aluminum Shells) |   |
|---|---|
| <b>Requirements</b>                               | <b>Cadmium with Olive Drab Passivation<br/>IAW QQ-P-416</b> |
| Thermal Shock                                     | -55°C + 125°C   |
| Salt Spray After Thermal Shock                    | 500 hour  |
| Electrical Conductivity                           | Very Good   |
| Abrasion Resistance                               | Very Good   |

**VG95328 L**  
**Bayonet-Lock**  
**Straight Plug Connector with Thumb-Lock Lever**  
**and Heat-Shrink Boot Backshell**

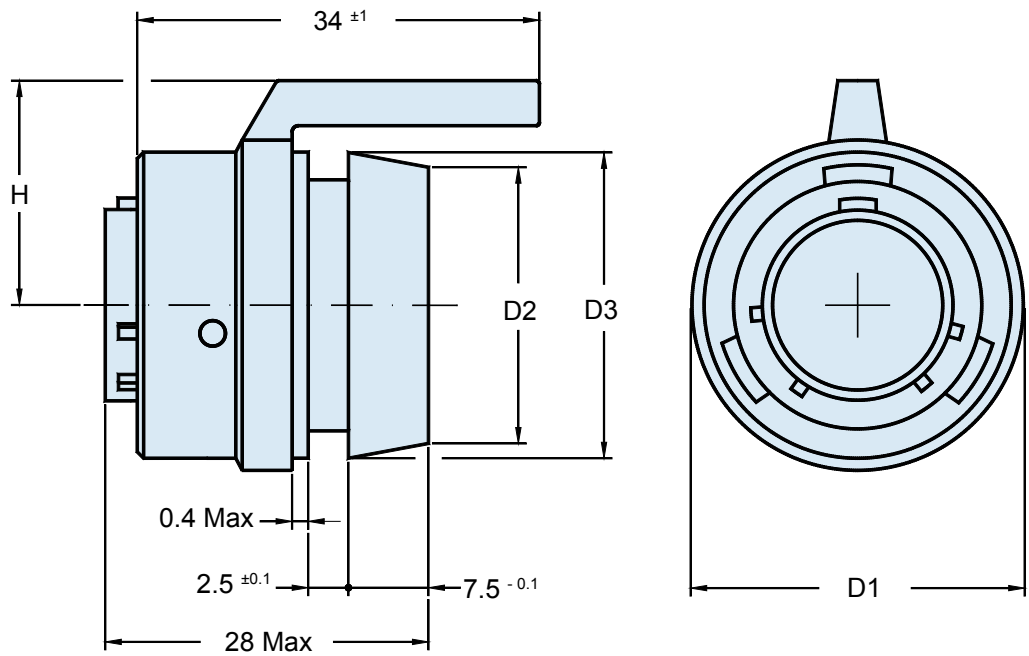
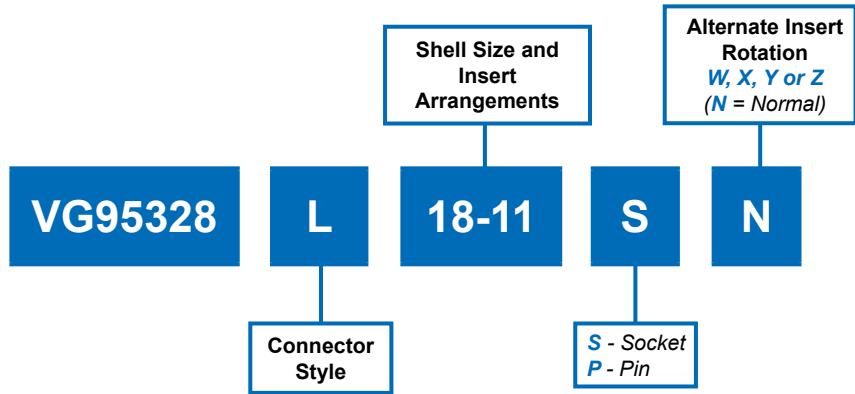

| Shell Size | D1 ± 1 | D2 ± 0.5 | D3 ± 0.5 | H ± 1 | Max Weight (g) |
|------------|--------|----------|----------|-------|----------------|
| 14         | 28     | 19.0     | 21       | 20    | 16             |
| 16         | 31     | 22.2     | 24       | 21    | 16             |

# VG95328 L Bayonet-Lock Straight Plug Connector with Thumb-Lock Lever and Heat-Shrink Boot Backshell



VG95328  
Connectors

| Contact Arrangements |                  |                   |    |
|----------------------|------------------|-------------------|----|
| Arrangement          | Cl. Isol. Rating | Dim. contact size |    |
|                      |                  | 20                | 16 |
| 8 - 3A               | I                | 3                 |    |
| 10 - 6               | I                | 6                 |    |
| 12 - 3               | II               |                   | 3  |
| 12 - 10              | I                | 10                |    |
| 14 - 5               | II               |                   | 5  |
| 14 - 12              | I                | 8                 | 4  |
| 14 - 15              | I                | 14                | 1  |
| 14 - 19              | I                | 19                |    |
| 16 - 8               | II               |                   | 8  |
| 16 - 23              | I                | 22                | 1  |
| 16 - 26              | I                | 26                |    |
| 18 - 11              | II               |                   | 11 |
| 18 - 32              | I                | 32                |    |
| 20 - 16              | II               |                   | 16 |
| 20 - 41              | I                | 41                |    |
| 22 - 21              | II               |                   | 21 |
| 22 - 55              | I                | 55                |    |
| 24 - 61              | I                | 61                |    |

| Alternate Insert Orientations |         |       |     |     |
|-------------------------------|---------|-------|-----|-----|
| Arrangement                   | Degrees |       |     |     |
|                               | W       | X     | Y   | Z   |
| 8 - 3A                        | 60      | (120) |     |     |
| 10 - 6                        | 90      |       |     |     |
| 12 - 3                        |         |       | 180 |     |
| 12 - 10                       | 60      | 155   | 270 | 295 |
| 14 - 5                        | 40      | 92    | 184 | 273 |
| 14 - 12                       | 43      | 90    |     |     |
| 14 - 15                       | 17      | 110   | 155 | 234 |
| 14 - 19                       | 30      | 165   | 315 |     |
| 16 - 8                        | 54      | 152   | 180 | 331 |
| 16 - 23                       | 158     | 270   |     |     |
| 16 - 26                       | 60      |       | 275 | 338 |
| 18 - 11                       | 62      | 119   | 241 | 340 |
| 18 - 32                       | 85      | 138   | 222 | 265 |
| 20 - 16                       | 238     | 318   | 333 | 347 |
| 20 - 41                       | 45      | 126   | 225 |     |
| 22 - 21                       | 16      | 135   | 175 | 349 |
| 22 - 55                       | 30      | 142   | 226 | 314 |
| 24 - 61                       | 90      | 180   | 270 | 324 |

**Class L, U, and W Thumb-Lock versions not qualified to VG95328. Please consult factory for Glenair commercial equivalent VG95328 type Thumb-Lock connectors**

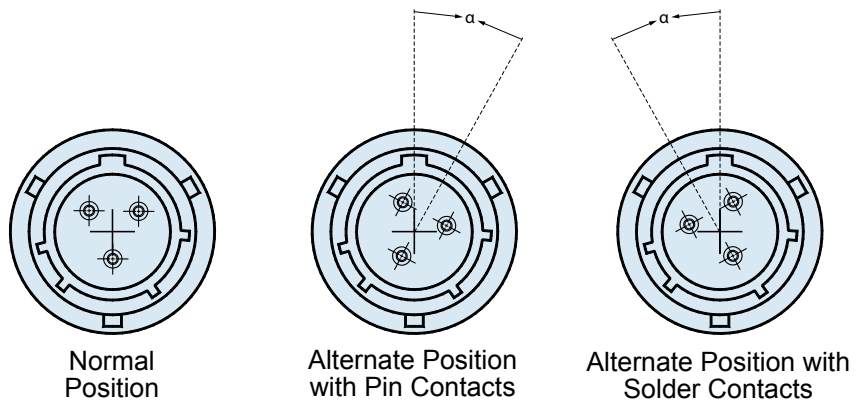

| MATERIALS                             |   |
|---------------------------------------|---|
| <b>SHELLS</b>                         | <b>INSERTS (Temperature Range)</b>                              |
| Aluminum Alloy<br>IAW QQ-A-591 Shells | High Insulation Synthetic Rubber<br>(Chloroprene): -55°C/+125°C |
| Stainless Steel<br>Coupling Pins      | <b>CRIMP CONTACTS</b>   |
| Stainless Steel Spring                | Copper Alloy with Gold Plating Over Nickel                      |

| STANDARD FINISH<br>(For QQ-A-591 Aluminum Shells) |   |
|---|---|
| <b>Requirements</b>                               | <b>Cadmium with Olive Drab Passivation<br/>IAW QQ-P-416</b> |
| Thermal Shock                                     | -55°C + 125°C   |
| Salt Spray After Thermal Shock                    | 500 hour  |
| Electrical Conductivity                           | Very Good   |
| Abrasion Resistance                               | Very Good   |

**VG95328 M**  
**Bayonet-Lock**  
**Straight Plug Connector**  
 with Ground-Fingers and EMI Shrink-Boot Backshell

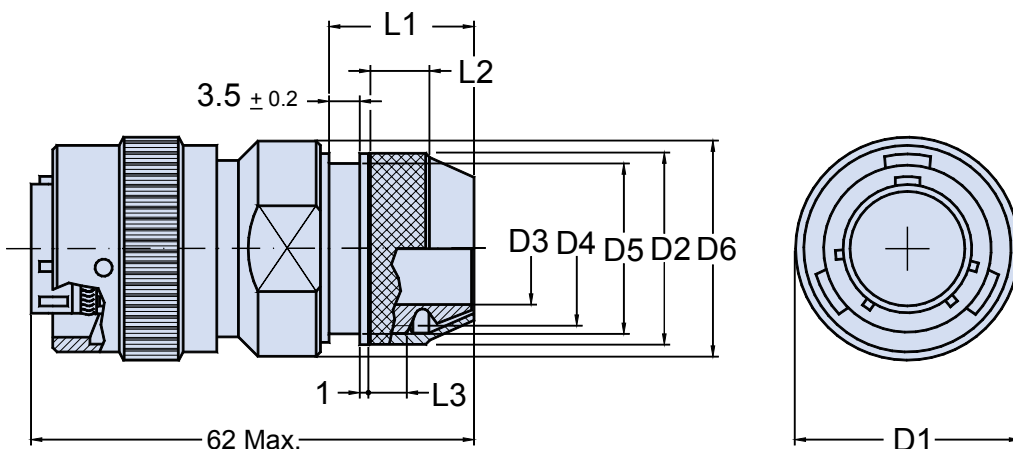
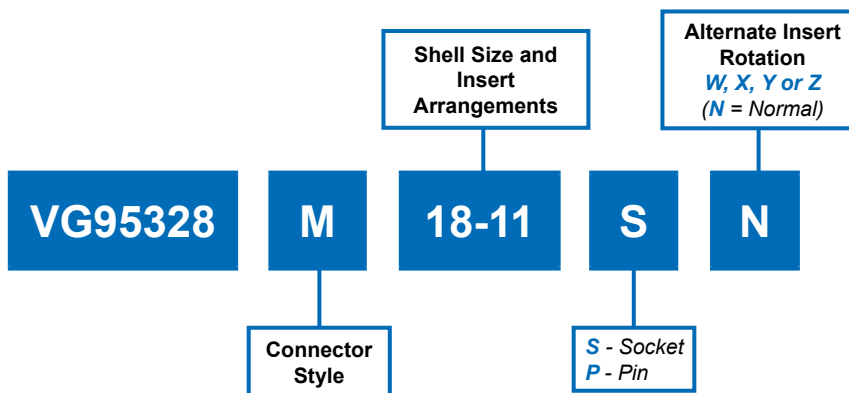

**TABLE I: DIMENSIONS**

| Shell size | D1<br>Max. | D2<br>+ 0.5<br>- 0 | D3<br>Min. | D4      | D5<br>+ 0<br>- 1 | D6<br>Max. | L1<br>+ 0<br>- 2.5 | L2<br>+ 1.5<br>- 0 | L3<br>Min. | Maximum<br>Weight in<br>Grams |
|------------|------------|--------------------|------------|---------|------------------|------------|--------------------|--------------------|------------|-------------------------------|
| 8          | 19.8       | 16                 | 6.6        | M14 x 1 | 14.0             | 20         | 17                 | 5                  | 4          | 27                            |
| 10         | 23.5       | 18                 | 9.2        | M16 x 1 | 16.0             | 23         | 17                 | 5                  | 4          | 29                            |
| 12         | 26.5       | 22                 | 12.2       | M20 x 1 | 20.0             | 27         | 17                 | 7                  | 5          | 35                            |
| 14         | 30.0       | 25                 | 15.2       | M23 x 1 | 23.0             | 30         | 18                 | 8                  | 6          | 45                            |
| 16         | 33.1       | 28                 | 18.3       | M26 x 1 | 26.0             | 33         | 18                 | 8                  | 6          | 52                            |
| 18         | 35.3       | 32                 | 20.0       | M30 x 1 | 28.5             | 36         | 18                 | 10                 | 6          | 67                            |
| 20         | 38.8       | 34                 | 23.0       | M32 x 1 | 30.5             | 40         | 18                 | 10                 | 6          | 84                            |
| 22         | 42.0       | 38                 | 26.0       | M36 x 1 | 34.5             | 43         | 18                 | 10                 | 6          | 102                           |
| 24         | 45.1       | 41                 | 28.8       | M39 x 1 | 37.5             | 46         | 18                 | 10                 | 6          | 109                           |

**VG95328 M**  
**Bayonet-Lock**  
**Straight Plug Connector**  
with Ground-Fingers and EMI Shrink-Boot Backshell



VG95328  
Connectors

| Contact Arrangements |                  |                   |    |
|----------------------|------------------|-------------------|----|
| Arrangement          | Cl. Isol. Rating | Dim. contact size |    |
|                      |                  | 20                | 16 |
| 8 - 3A               | I                | 3                 |    |
| 10 - 6               | I                | 6                 |    |
| 12 - 3               | II               |                   | 3  |
| 12 - 10              | I                | 10                |    |
| 14 - 5               | II               |                   | 5  |
| 14 - 12              | I                | 8                 | 4  |
| 14 - 15              | I                | 14                | 1  |
| 14 - 19              | I                | 19                |    |
| 16 - 8               | II               |                   | 8  |
| 16 - 23              | I                | 22                | 1  |
| 16 - 26              | I                | 26                |    |
| 18 - 11              | II               |                   | 11 |
| 18 - 32              | I                | 32                |    |
| 20 - 16              | II               |                   | 16 |
| 20 - 41              | I                | 41                |    |
| 22 - 21              | II               |                   | 21 |
| 22 - 55              | I                | 55                |    |
| 24 - 61              | I                | 61                |    |

| Alternate Insert Orientations |         |       |     |     |
|-------------------------------|---------|-------|-----|-----|
| Arrangement                   | Degrees |       |     |     |
|                               | W       | X     | Y   | Z   |
| 8 - 3A                        | 60      | (120) |     |     |
| 10 - 6                        | 90      |       |     |     |
| 12 - 3                        |         |       | 180 |     |
| 12 - 10                       | 60      | 155   | 270 | 295 |
| 14 - 5                        | 40      | 92    | 184 | 273 |
| 14 - 12                       | 43      | 90    |     |     |
| 14 - 15                       | 17      | 110   | 155 | 234 |
| 14 - 19                       | 30      | 165   | 315 |     |
| 16 - 8                        | 54      | 152   | 180 | 331 |
| 16 - 23                       | 158     | 270   |     |     |
| 16 - 26                       | 60      |       | 275 | 338 |
| 18 - 11                       | 62      | 119   | 241 | 340 |
| 18 - 32                       | 85      | 138   | 222 | 265 |
| 20 - 16                       | 238     | 318   | 333 | 347 |
| 20 - 41                       | 45      | 126   | 225 |     |
| 22 - 21                       | 16      | 135   | 175 | 349 |
| 22 - 55                       | 30      | 142   | 226 | 314 |
| 24 - 61                       | 90      | 180   | 270 | 324 |

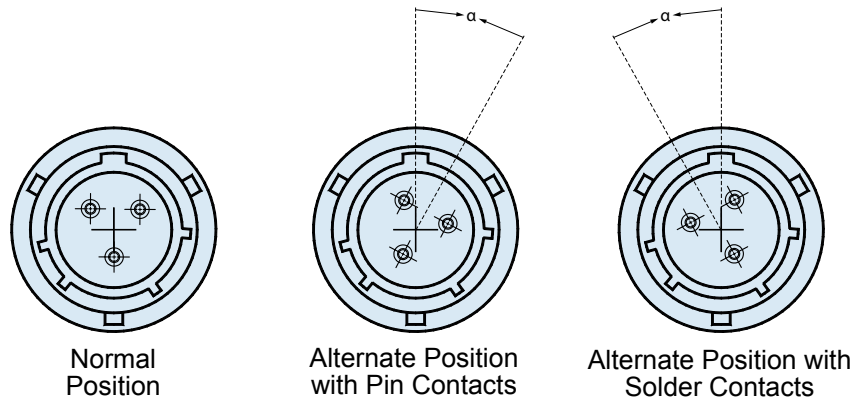

| MATERIALS                             |   |
|---------------------------------------|---|
| <b>SHELLS</b>                         | <b>INSERTS (Temperature Range)</b>                              |
| Aluminum Alloy<br>IAW QQ-A-591 Shells | High Insulation Synthetic Rubber<br>(Chloroprene): -55°C/+125°C |
| Stainless Steel<br>Coupling Pins      | <b>CRIMP CONTACTS</b>   |
| Stainless Steel Spring                | Copper Alloy with Gold Plating Over Nickel                      |

| STANDARD FINISH<br>(For QQ-A-591 Aluminum Shells) |   |
|---|---|
| <b>Requirements</b>                               | <b>Cadmium with Olive Drab Passivation IAW QQ-P-416</b> |
| Thermal Shock                                     | -55°C + 125°C   |
| Salt Spray After Thermal Shock                    | 500 hour  |
| Electrical Conductivity                           | Very Good   |
| Abrasion Resistance                               | Very Good   |

**VG95328 N**  
**Bayonet-Lock**  
**Straight Plug Connector**  
 with Backshell to Accommodate MS3057 Cable Clamp

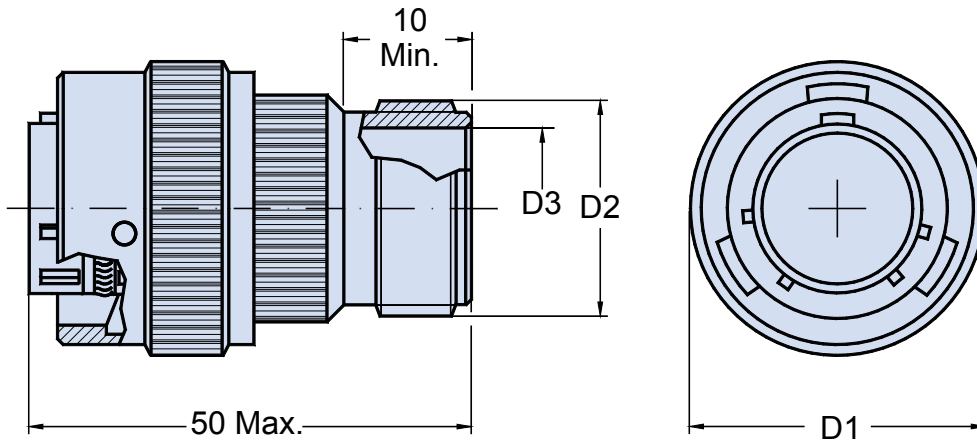
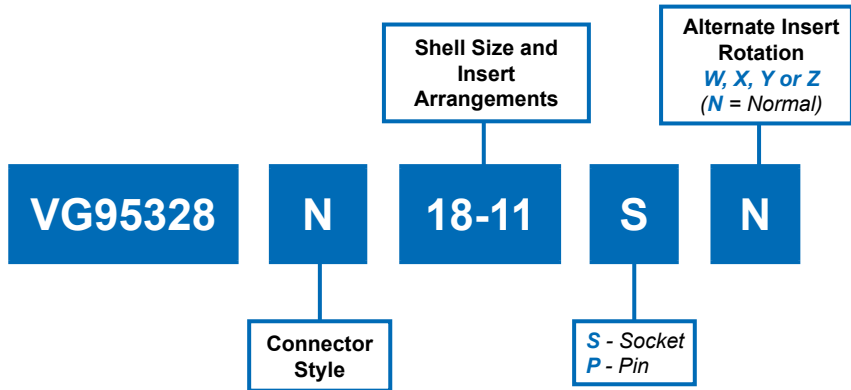

**TABLE I: DIMENSIONS**

| Shell size | D1 Max. | D2              | D3 Min. | Maximum Weight in Grams |
|------------|---------|-----------------|---------|-------------------------|
| 8          | 19.8    | 0.5000 - 28UNEF | 6.6     | 22                      |
| 10         | 23.5    | 0.6250 - 24UNEF | 9.2     | 22                      |
| 12         | 26.5    | 0.7500 - 20UNEF | 12.2    | 28                      |
| 14         | 30.0    | 0.8750 - 20UNEF | 15.2    | 38                      |
| 16         | 33.1    | 1.0000 - 20UNEF | 18.3    | 45                      |
| 18         | 35.3    | 1.1875 - 18UNEF | 20.0    | 60                      |
| 20         | 38.8    | 1.1875 - 18UNEF | 23.0    | 77                      |
| 22         | 42.0    | 1.4375 - 18UNEF | 26.0    | 95                      |
| 24         | 45.1    | 1.4375 - 18UNEF | 28.8    | 102                     |

Cable Clamp Sold Separately



# VG95328 N Bayonet-Lock Straight Plug Connector with Backshell to Accommodate MS3057 Cable Clamp



VG95328  
Connectors

| Contact Arrangements |                  |                   |    |
|----------------------|------------------|-------------------|----|
| Arrangement          | Cl. Isol. Rating | Dim. contact size |    |
|                      |                  | 20                | 16 |
| 8 - 3A               | I                | 3                 |    |
| 10 - 6               | I                | 6                 |    |
| 12 - 3               | II               |                   | 3  |
| 12 - 10              | I                | 10                |    |
| 14 - 5               | II               |                   | 5  |
| 14 - 12              | I                | 8                 | 4  |
| 14 - 15              | I                | 14                | 1  |
| 14 - 19              | I                | 19                |    |
| 16 - 8               | II               |                   | 8  |
| 16 - 23              | I                | 22                | 1  |
| 16 - 26              | I                | 26                |    |
| 18 - 11              | II               |                   | 11 |
| 18 - 32              | I                | 32                |    |
| 20 - 16              | II               |                   | 16 |
| 20 - 41              | I                | 41                |    |
| 22 - 21              | II               |                   | 21 |
| 22 - 55              | I                | 55                |    |
| 24 - 61              | I                | 61                |    |

| Alternate Insert Orientations |         |       |     |     |
|-------------------------------|---------|-------|-----|-----|
| Arrangement                   | Degrees |       |     |     |
|                               | W       | X     | Y   | Z   |
| 8 - 3A                        | 60      | (120) |     |     |
| 10 - 6                        | 90      |       |     |     |
| 12 - 3                        |         |       | 180 |     |
| 12 - 10                       | 60      | 155   | 270 | 295 |
| 14 - 5                        | 40      | 92    | 184 | 273 |
| 14 - 12                       | 43      | 90    |     |     |
| 14 - 15                       | 17      | 110   | 155 | 234 |
| 14 - 19                       | 30      | 165   | 315 |     |
| 16 - 8                        | 54      | 152   | 180 | 331 |
| 16 - 23                       | 158     | 270   |     |     |
| 16 - 26                       | 60      |       | 275 | 338 |
| 18 - 11                       | 62      | 119   | 241 | 340 |
| 18 - 32                       | 85      | 138   | 222 | 265 |
| 20 - 16                       | 238     | 318   | 333 | 347 |
| 20 - 41                       | 45      | 126   | 225 |     |
| 22 - 21                       | 16      | 135   | 175 | 349 |
| 22 - 55                       | 30      | 142   | 226 | 314 |
| 24 - 61                       | 90      | 180   | 270 | 324 |

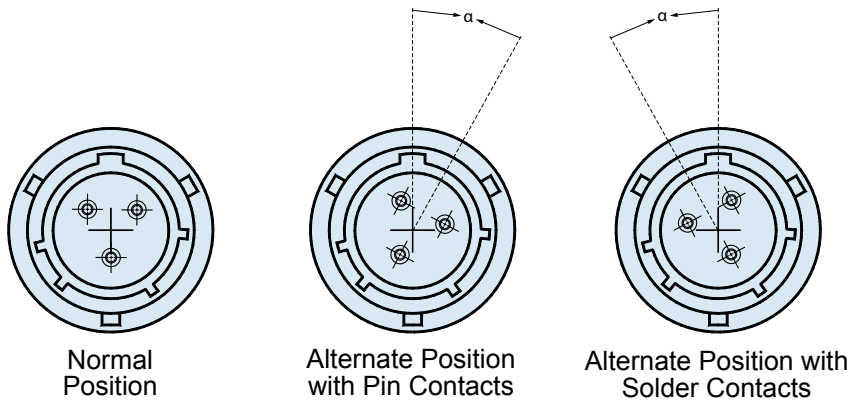

| MATERIALS                             |   |
|---------------------------------------|---|
| <b>SHELLS</b>                         | <b>INSERTS (Temperature Range)</b>                              |
| Aluminum Alloy<br>IAW QQ-A-591 Shells | High Insulation Synthetic Rubber<br>(Chloroprene): -55°C/+125°C |
| Stainless Steel<br>Coupling Pins      | <b>CRIMP CONTACTS</b>   |
| Stainless Steel Spring                | Copper Alloy with Gold Plating Over Nickel                      |

| STANDARD FINISH<br>(For QQ-A-591 Aluminum Shells) |   |
|---|---|
| <b>Requirements</b>                               | <b>Cadmium with Olive Drab Passivation<br/>IAW QQ-P-416</b> |
| Thermal Shock                                     | -55°C + 125°C   |
| Salt Spray After Thermal Shock                    | 500 hour  |
| Electrical Conductivity                           | Very Good   |
| Abrasion Resistance                               | Very Good   |

**VG95328 P**  
**Bayonet-Lock**  
Rear Mount Square Flange Through Bulkhead Receptacle  
Pre-Assembled with Solid Contacts

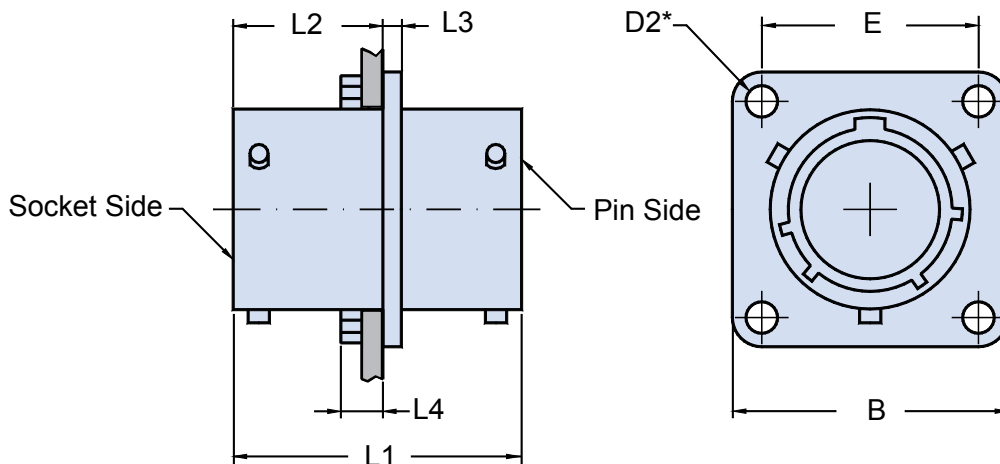
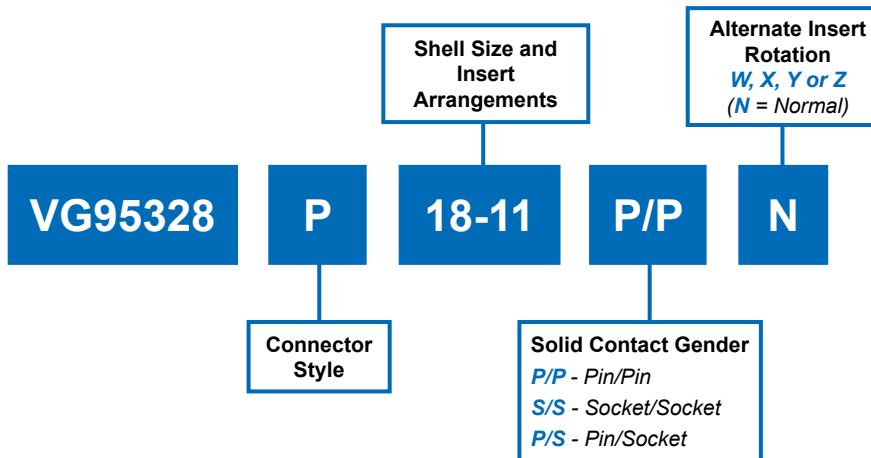

| TABLE I: DIMENSIONS |        |         |          |         |               |          |         |                         |
|---------------------|--------|---------|----------|---------|---------------|----------|---------|-------------------------|
| Shell size          | B Max. | D2 Min. | E ± 0.15 | L1 Max. | L2 + 0.79 - 0 | L3 ± 0.4 | L4 Max. | Maximum Weight in Grams |
| 8                   | 21.03  | 2.9     | 15.08    | 29      | 14.27         | 1.57     | 5.54    | 10                      |
| 10                  | 24.23  | 2.9     | 18.26    | 29      | 14.27         | 1.57     | 5.54    | 11                      |
| 12                  | 26.59  | 2.9     | 20.62    | 29      | 14.27         | 1.57     | 5.54    | 14                      |
| 14                  | 28.98  | 2.9     | 23.01    | 29      | 14.27         | 1.57     | 5.54    | 16                      |
| 16                  | 31.34  | 2.9     | 24.61    | 29      | 14.27         | 1.57     | 5.54    | 18                      |
| 18                  | 33.73  | 2.9     | 26.97    | 29      | 14.27         | 1.57     | 5.54    | 21                      |
| 20                  | 36.90  | 2.9     | 29.36    | 36      | 17.47         | 2.39     | 8.74    | 25                      |
| 22                  | 40.08  | 2.9     | 31.75    | 36      | 17.47         | 2.39     | 8.74    | 29                      |
| 24                  | 43.25  | 3.6     | 34.92    | 36      | 17.47         | 2.39     | 7.90    | 31                      |

\* Through Mounting Holes

# VG95328 P Bayonet-Lock Rear Mount Square Flange Through Bulkhead Receptacle Pre-Assembled with Solid Contacts



VG95328  
Connectors

| Contact Arrangements |                  |                   |    |
|----------------------|------------------|-------------------|----|
| Arrangement          | Cl. Isol. Rating | Dim. contact size |    |
|                      |                  | 20                | 16 |
| 8 - 3A               | I                | 3                 |    |
| 10 - 6               | I                | 6                 |    |
| 12 - 3               | II               |                   | 3  |
| 12 - 10              | I                | 10                |    |
| 14 - 5               | II               |                   | 5  |
| 14 - 12              | I                | 8                 | 4  |
| 14 - 15              | I                | 14                | 1  |
| 14 - 19              | I                | 19                |    |
| 16 - 8               | II               |                   | 8  |
| 16 - 23              | I                | 22                | 1  |
| 16 - 26              | I                | 26                |    |
| 18 - 11              | II               |                   | 11 |
| 18 - 32              | I                | 32                |    |
| 20 - 16              | II               |                   | 16 |
| 20 - 41              | I                | 41                |    |
| 22 - 21              | II               |                   | 21 |
| 22 - 55              | I                | 55                |    |
| 24 - 61              | I                | 61                |    |

| Alternate Insert Orientations |         |       |     |     |
|-------------------------------|---------|-------|-----|-----|
| Arrangement                   | Degrees |       |     |     |
|                               | W       | X     | Y   | Z   |
| 8 - 3A                        | 60      | (120) |     |     |
| 10 - 6                        | 90      |       |     |     |
| 12 - 3                        |         |       | 180 |     |
| 12 - 10                       | 60      | 155   | 270 | 295 |
| 14 - 5                        | 40      | 92    | 184 | 273 |
| 14 - 12                       | 43      | 90    |     |     |
| 14 - 15                       | 17      | 110   | 155 | 234 |
| 14 - 19                       | 30      | 165   | 315 |     |
| 16 - 8                        | 54      | 152   | 180 | 331 |
| 16 - 23                       | 158     | 270   |     |     |
| 16 - 26                       | 60      |       | 275 | 338 |
| 18 - 11                       | 62      | 119   | 241 | 340 |
| 18 - 32                       | 85      | 138   | 222 | 265 |
| 20 - 16                       | 238     | 318   | 333 | 347 |
| 20 - 41                       | 45      | 126   | 225 |     |
| 22 - 21                       | 16      | 135   | 175 | 349 |
| 22 - 55                       | 30      | 142   | 226 | 314 |
| 24 - 61                       | 90      | 180   | 270 | 324 |

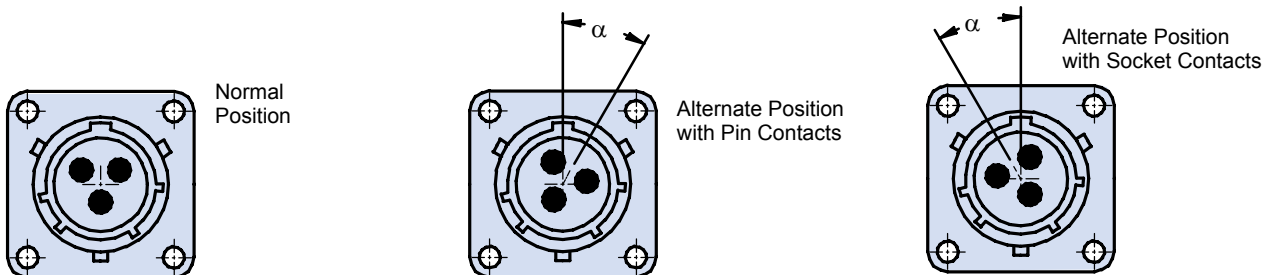

| MATERIALS                             |   |
|---------------------------------------|---|
| SHELLS                                | INSERTS (Temperature Range)                                     |
| Aluminum Alloy<br>IAW QQ-A-591 Shells | High Insulation Synthetic Rubber<br>(Chloroprene): -55°C/+125°C |
| Stainless Steel<br>Coupling Pins      | <b>SOLID CONTACTS</b>   |
| Stainless Steel Spring                | Copper Alloy with Gold Plating Over Nickel                      |

| STANDARD FINISH<br>(For QQ-A-591 Aluminum Shells) |  |
|---|--|
| Requirements                                      | Cadmium with Olive<br>Drab Passivation<br>IAW QQ-P-416 |
| Thermal Shock                                     | -55°C + 125°C  |
| Salt Spray After<br>Thermal Shock                 | 500 hour   |
| Electrical Conductivity                           | Very Good  |
| Abrasion Resistance                               | Very Good  |

See Page 13 for Panel Thickness and Cutout Dimensions

**VG95328 R**  
**Bayonet-Lock**  
**Front Panel Mount Square Flange Receptacle**  
**with Backshell for EMI Shield Termination and Shrink Boot**

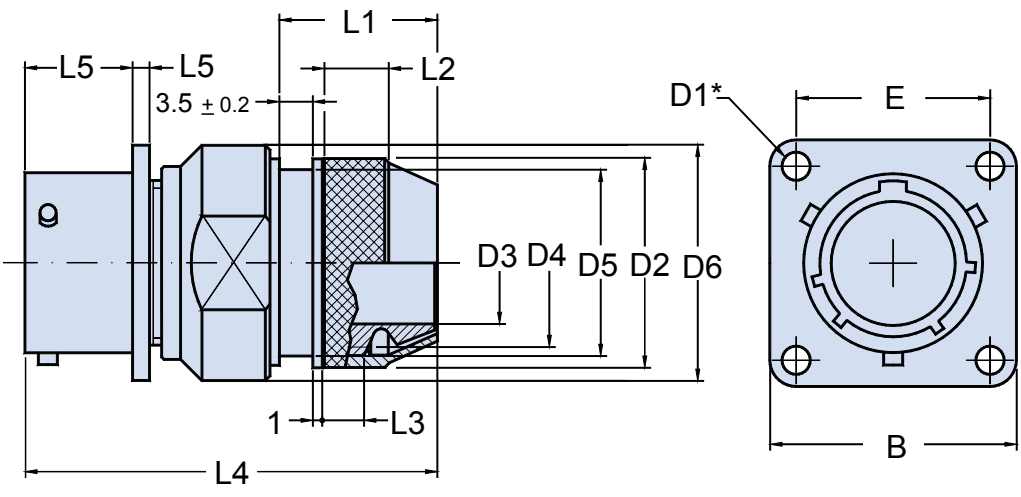
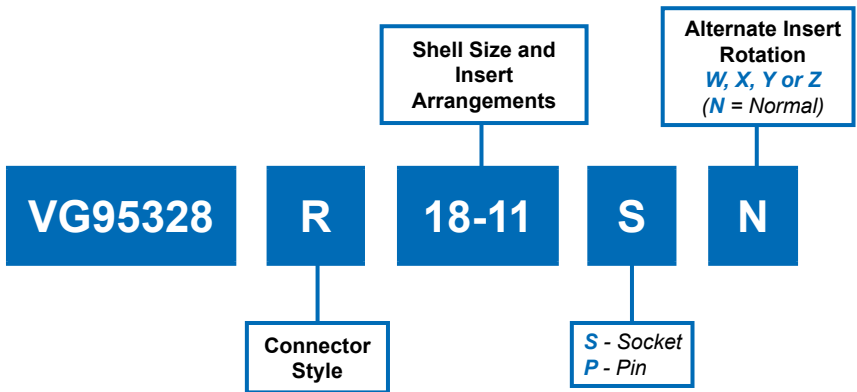

**TABLE I: DIMENSIONS**

| Shell size | B Max. | D1 Min. | E ± 0.15 | L4 Max. | L5 + 0.8 - 0 | L6 Max. | Maximum Weight in Grams |
|------------|--------|---------|----------|---------|--------------|---------|-------------------------|
| 8          | 21.03  | 2.9     | 15.08    | 54      | 10.94        | 2.0     | 26                      |
| 10         | 24.23  | 2.9     | 18.26    | 54      | 10.94        | 2.0     | 32                      |
| 12         | 26.59  | 2.9     | 20.62    | 54      | 10.94        | 2.0     | 38                      |
| 14         | 28.98  | 2.9     | 23.01    | 54      | 10.94        | 2.0     | 44                      |
| 16         | 31.34  | 2.9     | 24.61    | 54      | 10.94        | 2.0     | 49                      |
| 18         | 33.73  | 2.9     | 26.97    | 54      | 10.94        | 2.0     | 60                      |
| 20         | 36.90  | 2.9     | 29.36    | 62      | 14.12        | 2.8     | 70                      |
| 22         | 40.08  | 2.9     | 31.75    | 62      | 14.12        | 2.8     | 73                      |
| 24         | 43.25  | 3.6     | 34.92    | 62      | 14.96        | 2.8     | 87                      |

\* Through Mounting Holes

# VG95328 R Bayonet-Lock Front Panel Mount Square Flange Receptacle with Backshell for EMI Shield Termination and Shrink Boot



VG95328  
Connectors

| Contact Arrangements |                  |                   |    |
|----------------------|------------------|-------------------|----|
| Arrangement          | Cl. Isol. Rating | Dim. contact size |    |
|                      |                  | 20                | 16 |
| 8 - 3A               | I                | 3                 |    |
| 10 - 6               | I                | 6                 |    |
| 12 - 3               | II               |                   | 3  |
| 12 - 10              | I                | 10                |    |
| 14 - 5               | II               |                   | 5  |
| 14 - 12              | I                | 8                 | 4  |
| 14 - 15              | I                | 14                | 1  |
| 14 - 19              | I                | 19                |    |
| 16 - 8               | II               |                   | 8  |
| 16 - 23              | I                | 22                | 1  |
| 16 - 26              | I                | 26                |    |
| 18 - 11              | II               |                   | 11 |
| 18 - 32              | I                | 32                |    |
| 20 - 16              | II               |                   | 16 |
| 20 - 41              | I                | 41                |    |
| 22 - 21              | II               |                   | 21 |
| 22 - 55              | I                | 55                |    |
| 24 - 61              | I                | 61                |    |

| Alternate Insert Orientations |         |       |     |     |
|-------------------------------|---------|-------|-----|-----|
| Arrangement                   | Degrees |       |     |     |
|                               | W       | X     | Y   | Z   |
| 8 - 3A                        | 60      | (120) |     |     |
| 10 - 6                        | 90      |       |     |     |
| 12 - 3                        |         |       | 180 |     |
| 12 - 10                       | 60      | 155   | 270 | 295 |
| 14 - 5                        | 40      | 92    | 184 | 273 |
| 14 - 12                       | 43      | 90    |     |     |
| 14 - 15                       | 17      | 110   | 155 | 234 |
| 14 - 19                       | 30      | 165   | 315 |     |
| 16 - 8                        | 54      | 152   | 180 | 331 |
| 16 - 23                       | 158     | 270   |     |     |
| 16 - 26                       | 60      |       | 275 | 338 |
| 18 - 11                       | 62      | 119   | 241 | 340 |
| 18 - 32                       | 85      | 138   | 222 | 265 |
| 20 - 16                       | 238     | 318   | 333 | 347 |
| 20 - 41                       | 45      | 126   | 225 |     |
| 22 - 21                       | 16      | 135   | 175 | 349 |
| 22 - 55                       | 30      | 142   | 226 | 314 |
| 24 - 61                       | 90      | 180   | 270 | 324 |

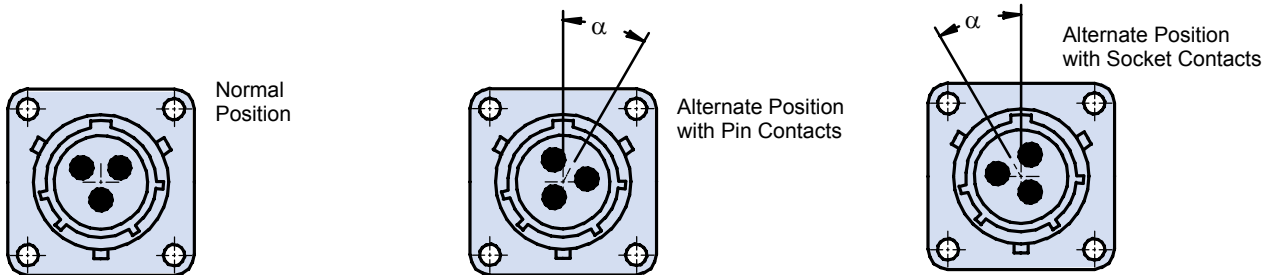

| MATERIALS  |   |
|--|---|
| <b>SHELLS</b><br>Aluminum Alloy<br>IAW QQ-A-591 Shells | <b>INSERTS (Temperature Range)</b><br>High Insulation Synthetic Rubber<br>(Chloroprene): -55°C/+125°C |
| Stainless Steel<br>Coupling Pins                       | <b>CRIMP CONTACTS</b>   |
| Stainless Steel Spring                                 | Copper Alloy with Gold Plating Over Nickel  |

| STANDARD FINISH<br>(For QQ-A-591 Aluminum Shells) |   |
|---|---|
| <b>Requirements</b>                               | <b>Cadmium with Olive<br/>Drab Passivation<br/>IAW QQ-P-416</b> |
| Thermal Shock                                     | -55°C + 125°C   |
| Salt Spray After<br>Thermal Shock                 | 500 hour  |
| Electrical Conductivity                           | Very Good   |
| Abrasion Resistance                               | Very Good   |

See Page 13 for Panel Thickness and Cutout Dimensions

**VG95328 S**  
**Bayonet-Lock**  
**Rear Panel Mount Jam Nut Receptacle Connector**  
**with Shrinkboot Backshell**

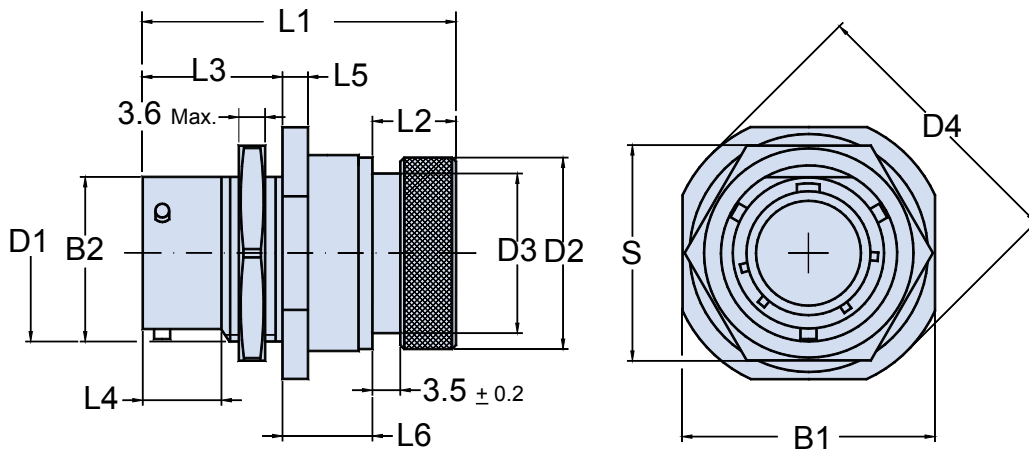
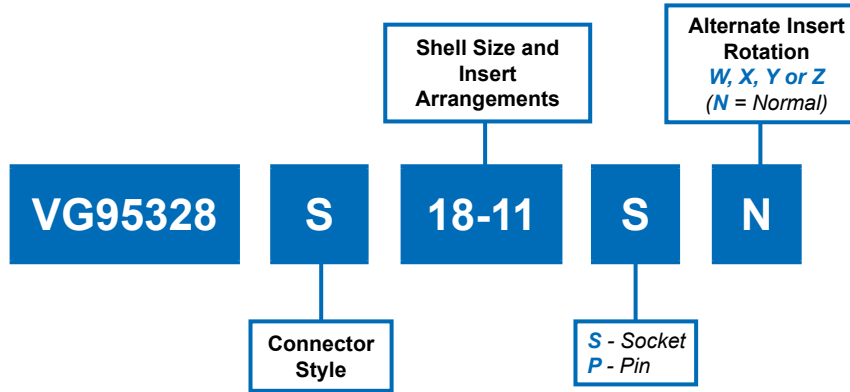

**TABLE I: DIMENSIONS**

| Shell size | B1<br>Max. | B2<br>+ 0<br>- 0.25 | D1            | D4<br>+ 0<br>- 0.8 | L1<br>Max. | L3<br>+ 0.8<br>- 0 | L4<br>Min. | L5<br>± 0.5 | L6<br>± 0.8 | S<br>± 0.43 | Maximum<br>Weight in<br>Grams |
|------------|------------|---------------------|---------------|--------------------|------------|--------------------|------------|-------------|-------------|-------------|-------------------------------|
| 8          | 24.3       | 13.46               | 0.5625-24UNEF | 27.3               | 43.0       | 17.5               | 9.75       | 3.0         | 12.6        | 19.05       | 20                            |
| 10         | 27.4       | 16.46               | 0.6875-24UNEF | 30.5               | 43.0       | 17.5               | 9.75       | 3.0         | 12.6        | 22.23       | 23                            |
| 12         | 32.2       | 20.78               | 0.8750-20UNEF | 35.3               | 43.0       | 17.5               | 9.75       | 3.0         | 12.6        | 26.97       | 30                            |
| 14         | 35.4       | 23.93               | 1.0000-20UNEF | 38.5               | 43.0       | 17.5               | 9.75       | 3.0         | 12.6        | 30.18       | 40                            |
| 16         | 38.6       | 27.08               | 1.1250-18UNEF | 41.6               | 45.5       | 17.5               | 9.75       | 3.0         | 12.6        | 33.32       | 50                            |
| 18         | 41.7       | 30.25               | 1.2500-18UNEF | 44.8               | 45.5       | 17.5               | 9.75       | 3.0         | 12.6        | 36.53       | 60                            |
| 20         | 46.5       | 33.43               | 1.3750-18UNEF | 49.6               | 53.5       | 22.3               | 11.32      | 3.8         | 13.7        | 39.67       | 80                            |
| 22         | 49.7       | 36.60               | 1.5000-18UNEF | 52.7               | 53.5       | 22.3               | 11.32      | 3.8         | 13.7        | 42.88       | 85                            |
| 24         | 52.8       | 39.78               | 1.6250-18UNEF | 55.9               | 53.5       | 23.1               | 12.16      | 3.8         | 14.0        | 46.02       | 90                            |

Single Hole Mounting

**VG95328 S**  
**Bayonet-Lock**  
**Rear Panel Mount Jam Nut Receptacle Connector**  
**with Shrinkboot Backshell**



VG95328  
Connectors

| Contact Arrangements |                  |                   |    |
|----------------------|------------------|-------------------|----|
| Arrangement          | Cl. Isol. Rating | Dim. contact size |    |
|                      |                  | 20                | 16 |
| 8 - 3A               | I                | 3                 |    |
| 10 - 6               | I                | 6                 |    |
| 12 - 3               | II               |                   | 3  |
| 12 - 10              | I                | 10                |    |
| 14 - 5               | II               |                   | 5  |
| 14 - 12              | I                | 8                 | 4  |
| 14 - 15              | I                | 14                | 1  |
| 14 - 19              | I                | 19                |    |
| 16 - 8               | II               |                   | 8  |
| 16 - 23              | I                | 22                | 1  |
| 16 - 26              | I                | 26                |    |
| 18 - 11              | II               |                   | 11 |
| 18 - 32              | I                | 32                |    |
| 20 - 16              | II               |                   | 16 |
| 20 - 41              | I                | 41                |    |
| 22 - 21              | II               |                   | 21 |
| 22 - 55              | I                | 55                |    |
| 24 - 61              | I                | 61                |    |

| Alternate Insert Orientations |         |       |     |     |
|-------------------------------|---------|-------|-----|-----|
| Arrangement                   | Degrees |       |     |     |
|                               | W       | X     | Y   | Z   |
| 8 - 3A                        | 60      | (120) |     |     |
| 10 - 6                        | 90      |       |     |     |
| 12 - 3                        |         |       | 180 |     |
| 12 - 10                       | 60      | 155   | 270 | 295 |
| 14 - 5                        | 40      | 92    | 184 | 273 |
| 14 - 12                       | 43      | 90    |     |     |
| 14 - 15                       | 17      | 110   | 155 | 234 |
| 14 - 19                       | 30      | 165   | 315 |     |
| 16 - 8                        | 54      | 152   | 180 | 331 |
| 16 - 23                       | 158     | 270   |     |     |
| 16 - 26                       | 60      |       | 275 | 338 |
| 18 - 11                       | 62      | 119   | 241 | 340 |
| 18 - 32                       | 85      | 138   | 222 | 265 |
| 20 - 16                       | 238     | 318   | 333 | 347 |
| 20 - 41                       | 45      | 126   | 225 |     |
| 22 - 21                       | 16      | 135   | 175 | 349 |
| 22 - 55                       | 30      | 142   | 226 | 314 |
| 24 - 61                       | 90      | 180   | 270 | 324 |

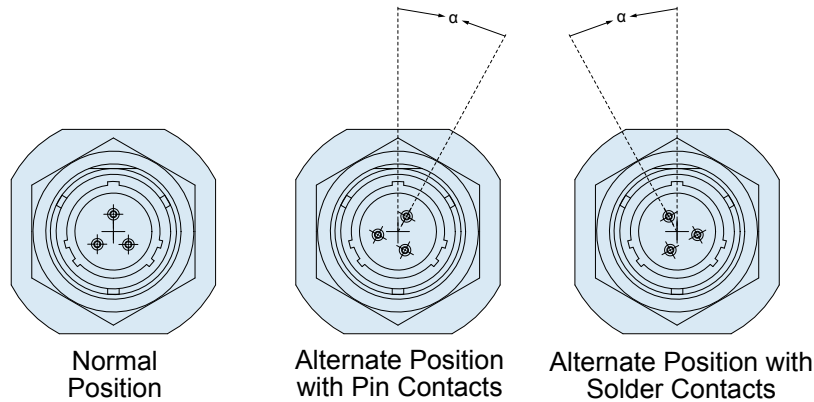

| MATERIALS                             |   |
|---------------------------------------|---|
| <b>SHELLS</b>                         | <b>INSERTS (Temperature Range)</b>                              |
| Aluminum Alloy<br>IAW QQ-A-591 Shells | High Insulation Synthetic Rubber<br>(Chloroprene): -55°C/+125°C |
| Stainless Steel<br>Coupling Pins      | <b>CRIMP CONTACTS</b>   |
| Stainless Steel Spring                | Copper Alloy with Gold Plating Over Nickel                      |

| STANDARD FINISH<br>(For QQ-A-591 Aluminum Shells) |   |
|---|---|
| <b>Requirements</b>                               | <b>Cadmium with Olive Drab Passivation<br/>IAW QQ-P-416</b> |
| Thermal Shock                                     | -55°C + 125°C   |
| Salt Spray After Thermal Shock                    | 500 hour  |
| Electrical Conductivity                           | Very Good   |
| Abrasion Resistance                               | Very Good   |

See Page 13 for Panel Thickness and Cutout Dimensions

**VG95328 T**  
**Bayonet-Lock**  
**Rear Panel Mount Jam Nut Receptacle**  
with Backshell for EMI Shield Termination and Shrink Boot

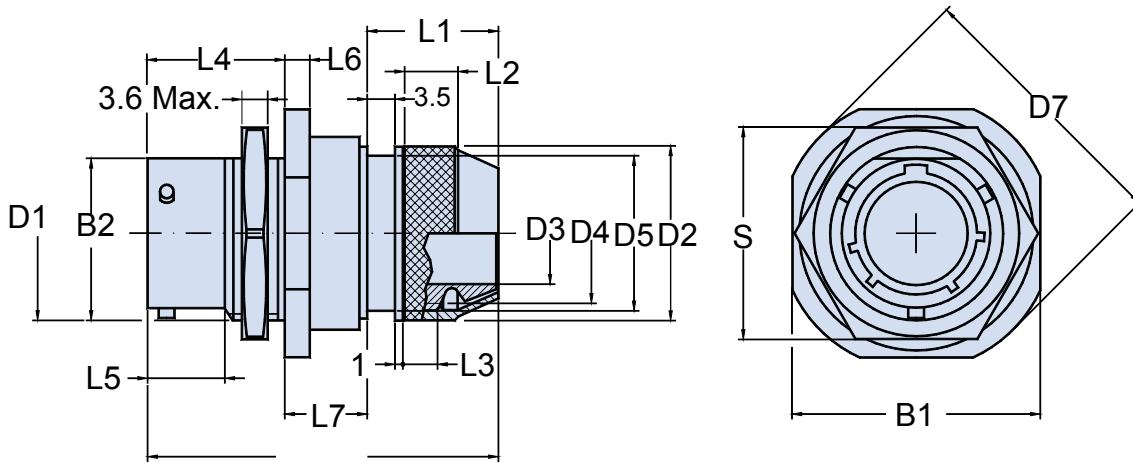
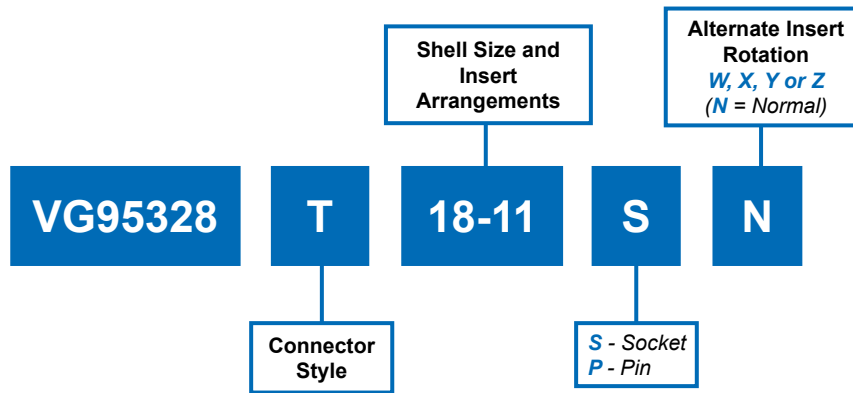

**TABLE I: DIMENSIONS**

| Shell size | B1 Max. | B2 +0 -0.25 | D1               | D7 +0 -0.8 | L4 +0.8 -0 | L5 Min. | L6 ±0.5 | L7 ±0.8 | S ±0.43 | Maximum Weight in Grams |
|------------|---------|-------------|------------------|------------|------------|---------|---------|---------|---------|-------------------------|
| 8          | 24.3    | 13.46       | .5625 - 24 UNEF  | 27.3       | 17.5       | 9.75    | 3.0     | 12.6    | 19.05   | 30                      |
| 10         | 27.4    | 16.64       | .6875 - 24 UNEF  | 30.5       | 17.5       | 9.75    | 3.0     | 12.6    | 22.23   | 35                      |
| 12         | 32.2    | 20.78       | .8750 - 20 UNEF  | 35.3       | 17.5       | 9.75    | 3.0     | 12.6    | 26.97   | 45                      |
| 14         | 35.4    | 23.93       | 1.0000 - 20 UNEF | 38.5       | 17.5       | 9.75    | 3.0     | 12.6    | 30.18   | 55                      |
| 16         | 38.6    | 27.08       | 1.1250 - 18 UNEF | 41.6       | 17.5       | 9.75    | 3.0     | 12.6    | 33.32   | 65                      |
| 18         | 41.7    | 30.25       | 1.2500 - 18 UNEF | 44.8       | 17.5       | 9.75    | 3.0     | 12.6    | 36.53   | 80                      |
| 20         | 46.5    | 33.43       | 1.3750 - 18 UNEF | 49.6       | 22.3       | 11.32   | 3.8     | 13.7    | 39.67   | 105                     |
| 22         | 49.7    | 36.60       | 1.5000 - 18 UNEF | 52.7       | 22.3       | 11.32   | 3.8     | 13.7    | 42.88   | 115                     |
| 24         | 52.8    | 39.78       | 1.6250 - 18 UNEF | 55.9       | 23.1       | 12.16   | 3.8     | 14.0    | 46.02   | 125                     |

For D2, D3, D4, D5, D6, L1, L2, and L3 Dimensions Please See VG95328 M

Single Hole Mounting



**VG95328 T**  
**Bayonet-Lock**  
**Rear Panel Mount Jam Nut Receptacle**  
**with Backshell for EMI Shield Termination and Shrink Boot**



VG95328  
Connectors

| Contact Arrangements |                  |                   |    |
|----------------------|------------------|-------------------|----|
| Arrangement          | Cl. Isol. Rating | Dim. contact size |    |
|                      |                  | 20                | 16 |
| 8 - 3A               | I                | 3                 |    |
| 10 - 6               | I                | 6                 |    |
| 12 - 3               | II               |                   | 3  |
| 12 - 10              | I                | 10                |    |
| 14 - 5               | II               |                   | 5  |
| 14 - 12              | I                | 8                 | 4  |
| 14 - 15              | I                | 14                | 1  |
| 14 - 19              | I                | 19                |    |
| 16 - 8               | II               |                   | 8  |
| 16 - 23              | I                | 22                | 1  |
| 16 - 26              | I                | 26                |    |
| 18 - 11              | II               |                   | 11 |
| 18 - 32              | I                | 32                |    |
| 20 - 16              | II               |                   | 16 |
| 20 - 41              | I                | 41                |    |
| 22 - 21              | II               |                   | 21 |
| 22 - 55              | I                | 55                |    |
| 24 - 61              | I                | 61                |    |

| Alternate Insert Orientations |         |       |     |     |
|-------------------------------|---------|-------|-----|-----|
| Arrangement                   | Degrees |       |     |     |
|                               | W       | X     | Y   | Z   |
| 8 - 3A                        | 60      | (120) |     |     |
| 10 - 6                        | 90      |       |     |     |
| 12 - 3                        |         |       | 180 |     |
| 12 - 10                       | 60      | 155   | 270 | 295 |
| 14 - 5                        | 40      | 92    | 184 | 273 |
| 14 - 12                       | 43      | 90    |     |     |
| 14 - 15                       | 17      | 110   | 155 | 234 |
| 14 - 19                       | 30      | 165   | 315 |     |
| 16 - 8                        | 54      | 152   | 180 | 331 |
| 16 - 23                       | 158     | 270   |     |     |
| 16 - 26                       | 60      |       | 275 | 338 |
| 18 - 11                       | 62      | 119   | 241 | 340 |
| 18 - 32                       | 85      | 138   | 222 | 265 |
| 20 - 16                       | 238     | 318   | 333 | 347 |
| 20 - 41                       | 45      | 126   | 225 |     |
| 22 - 21                       | 16      | 135   | 175 | 349 |
| 22 - 55                       | 30      | 142   | 226 | 314 |
| 24 - 61                       | 90      | 180   | 270 | 324 |

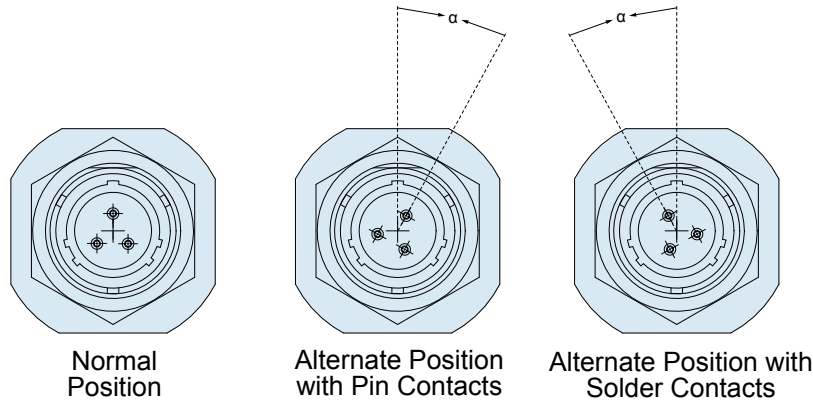

| MATERIALS                             |   |
|---------------------------------------|---|
| <b>SHELLS</b>                         | <b>INSERTS (Temperature Range)</b>                              |
| Aluminum Alloy<br>IAW QQ-A-591 Shells | High Insulation Synthetic Rubber<br>(Chloroprene): -55°C/+125°C |
| Stainless Steel<br>Coupling Pins      | <b>CRIMP CONTACTS</b>   |
| Stainless Steel Spring                | Copper Alloy with Gold Plating Over Nickel                      |

| STANDARD FINISH<br>(For QQ-A-591 Aluminum Shells) |   |
|---|---|
| <b>Requirements</b>                               | <b>Cadmium with Olive Drab Passivation<br/>IAW QQ-P-416</b> |
| Thermal Shock                                     | -55°C + 125°C   |
| Salt Spray After Thermal Shock                    | 500 hour  |
| Electrical Conductivity                           | Very Good   |
| Abrasion Resistance                               | Very Good   |

See Page 13 for Panel Thickness and Cutout Dimensions

**VG95328 U**  
**Bayonet-Lock**  
Straight Plug Connector with Thumb-Lock Lever,  
Grounding-Fingers and EMI/Shrinkboot Backshell

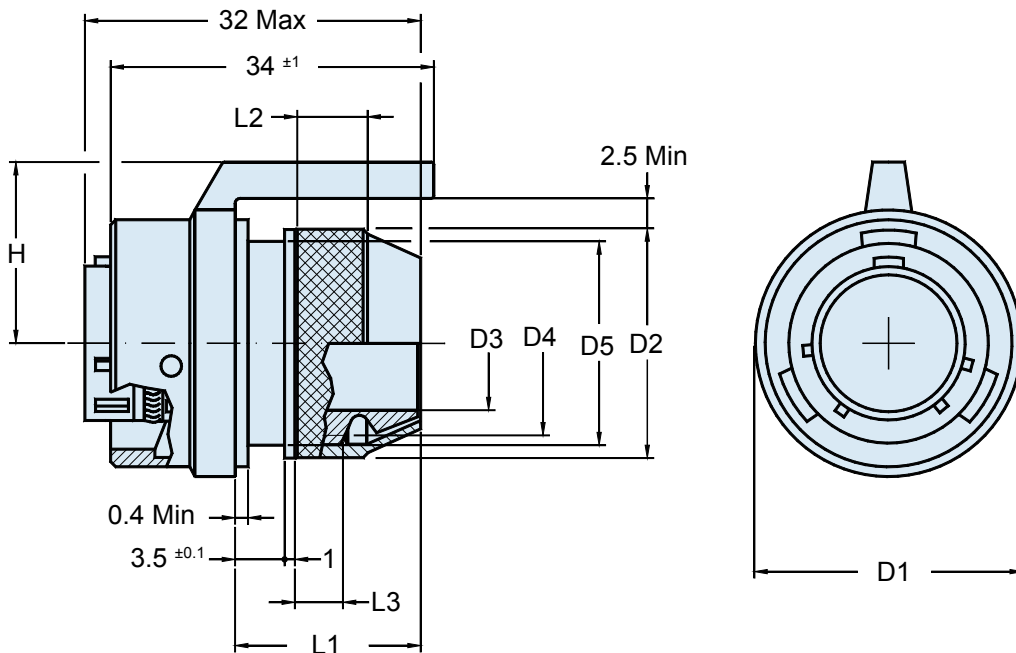
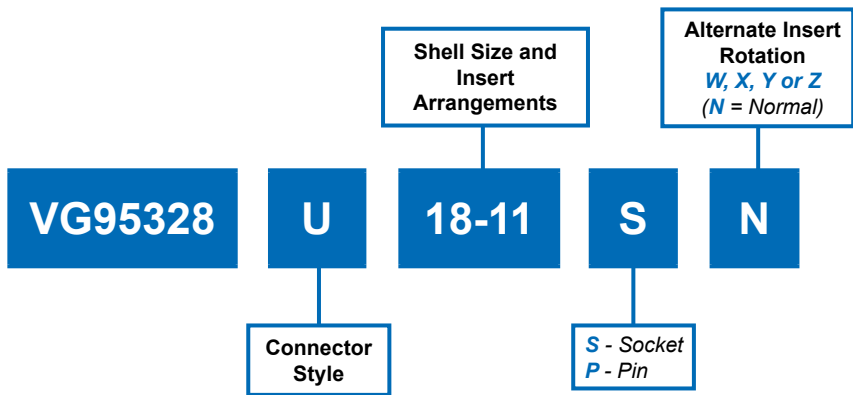

| Shell Size | D1 ± 1 | H ± 1 | Max Weight (g) |
|------------|--------|-------|----------------|
| 12         | 24     | 19    | 18             |
| 14         | 28     | 20    | 20             |
| 16         | 31     | 21    | 22             |

# VG95328 U Bayonet-Lock Straight Plug Connector with Thumb-Lock Lever, Grounding-Fingers and EMI/Shrinkboot Backshell



VG95328  
Connectors

| Contact Arrangements |                  |                   |    |
|----------------------|------------------|-------------------|----|
| Arrangement          | Cl. Isol. Rating | Dim. contact size |    |
|                      |                  | 20                | 16 |
| 8 - 3A               | I                | 3                 |    |
| 10 - 6               | I                | 6                 |    |
| 12 - 3               | II               |                   | 3  |
| 12 - 10              | I                | 10                |    |
| 14 - 5               | II               |                   | 5  |
| 14 - 12              | I                | 8                 | 4  |
| 14 - 15              | I                | 14                | 1  |
| 14 - 19              | I                | 19                |    |
| 16 - 8               | II               |                   | 8  |
| 16 - 23              | I                | 22                | 1  |
| 16 - 26              | I                | 26                |    |
| 18 - 11              | II               |                   | 11 |
| 18 - 32              | I                | 32                |    |
| 20 - 16              | II               |                   | 16 |
| 20 - 41              | I                | 41                |    |
| 22 - 21              | II               |                   | 21 |
| 22 - 55              | I                | 55                |    |
| 24 - 61              | I                | 61                |    |

| Alternate Insert Orientations |         |       |     |     |
|-------------------------------|---------|-------|-----|-----|
| Arrangement                   | Degrees |       |     |     |
|                               | W       | X     | Y   | Z   |
| 8 - 3A                        | 60      | (120) |     |     |
| 10 - 6                        | 90      |       |     |     |
| 12 - 3                        |         |       | 180 |     |
| 12 - 10                       | 60      | 155   | 270 | 295 |
| 14 - 5                        | 40      | 92    | 184 | 273 |
| 14 - 12                       | 43      | 90    |     |     |
| 14 - 15                       | 17      | 110   | 155 | 234 |
| 14 - 19                       | 30      | 165   | 315 |     |
| 16 - 8                        | 54      | 152   | 180 | 331 |
| 16 - 23                       | 158     | 270   |     |     |
| 16 - 26                       | 60      |       | 275 | 338 |
| 18 - 11                       | 62      | 119   | 241 | 340 |
| 18 - 32                       | 85      | 138   | 222 | 265 |
| 20 - 16                       | 238     | 318   | 333 | 347 |
| 20 - 41                       | 45      | 126   | 225 |     |
| 22 - 21                       | 16      | 135   | 175 | 349 |
| 22 - 55                       | 30      | 142   | 226 | 314 |
| 24 - 61                       | 90      | 180   | 270 | 324 |

**Class L, U, and W Thumb-Lock versions not qualified to VG95328. Please consult factory for Glenair commercial equivalent VG95328 type Thumb-Lock connectors**

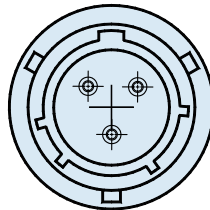

Normal Position

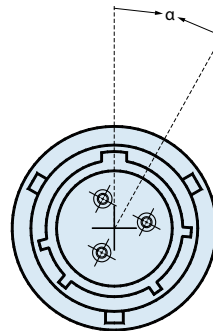

Alternate Position with Pin Contacts

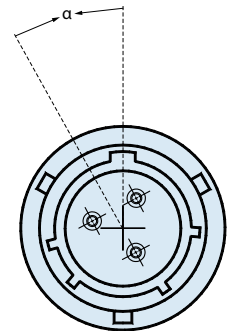

Alternate Position with Solder Contacts

| MATERIALS                             |   |
|---------------------------------------|---|
| <b>SHELLS</b>                         | <b>INSERTS (Temperature Range)</b>                              |
| Aluminum Alloy<br>IAW QQ-A-591 Shells | High Insulation Synthetic Rubber<br>(Chloroprene): -55°C/+125°C |
| Stainless Steel<br>Coupling Pins      | <b>CRIMP CONTACTS</b>   |
| Stainless Steel Spring                | Copper Alloy with Gold Plating Over Nickel                      |

| STANDARD FINISH<br>(For QQ-A-591 Aluminum Shells) |   |
|---|---|
| <b>Requirements</b>                               | <b>Cadmium with Olive Drab Passivation<br/>IAW QQ-P-416</b> |
| Thermal Shock                                     | -55°C + 125°C   |
| Salt Spray After Thermal Shock                    | 500 hour  |
| Electrical Conductivity                           | Very Good   |
| Abrasion Resistance                               | Very Good   |

**VG95328 V**  
**Bayonet-Lock**  
**Straight Plug Connector**  
with Ground-Fingers and EMI/Shrinkboot Backshell

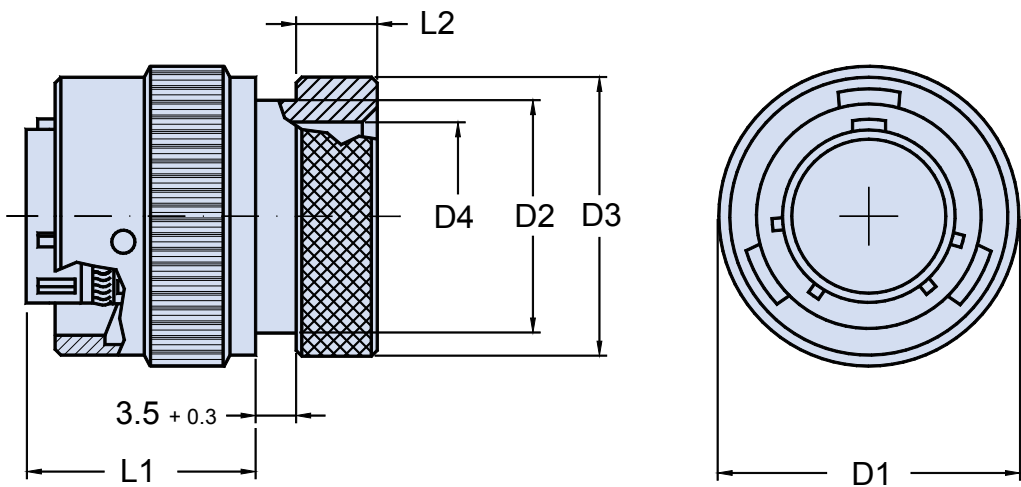
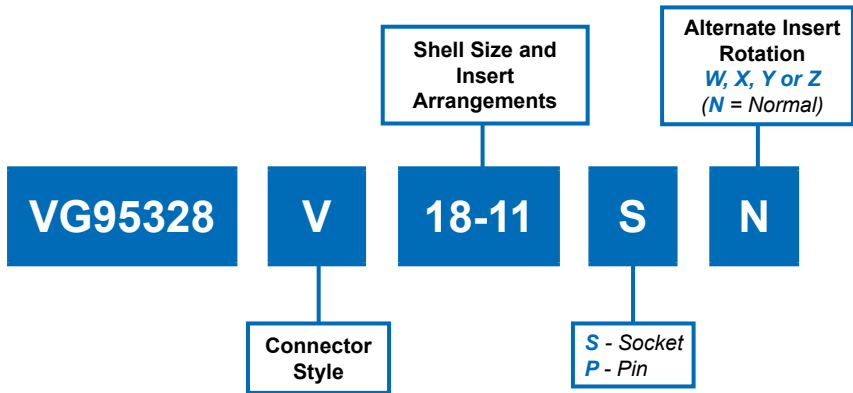

**TABLE I: DIMENSIONS**

| Shell size | D1<br>Max. | D2<br>+ 0.15<br>- 0 | D3    |       | D4    |       | L1<br>Max. | L2<br>Min. | Maximum<br>Weight in<br>Grams |
|------------|------------|---------------------|-------|-------|-------|-------|------------|------------|-------------------------------|
|            |            |                     | Limit | Limit | Limit | Limit |            |            |                               |
| 8          | 19.8       | 9.40                | 13.8  | -2.00 | 7.0   | +2.5  | 23         | 6.5        | 14                            |
| 10         | 23.5       | 12.60               | 16.6  | -1.60 | 10.4  | +2.1  | 23         | 6.5        | 16                            |
| 12         | 26.5       | 15.75               | 19.8  | -1.65 | 13.9  | +1.7  | 23         | 6.5        | 23                            |
| 14         | 30.0       | 18.40               | 23.0  | -2.20 | 16.5  | +2.2  | 23         | 6.5        | 30                            |
| 16         | 33.1       | 21.60               | 26.2  | -2.20 | 19.7  | +2.1  | 23         | 6.5        | 43                            |
| 18         | 35.3       | 24.40               | 29.0  | -2.20 | 22.3  | +2.4  | 23         | 8.5        | 46                            |
| 20         | 38.8       | 26.00               | 32.3  | -2.30 | 25.5  | +2.4  | 28         | 8.5        | 63                            |
| 22         | 42.0       | 29.40               | 36.6  | -2.20 | 28.7  | +2.4  | 28         | 8.5        | 78                            |
| 24         | 45.1       | 32.50               | 39.8  | -3.30 | 31.8  | +2.5  | 28         | 8.5        | 84                            |

**VG95328 V**  
**Bayonet-Lock**  
**Straight Plug Connector**  
**with Ground-Fingers and EMI/Shrinkboot Backshell**



VG95328  
Connectors

| Contact Arrangements |                  |                   |    |
|----------------------|------------------|-------------------|----|
| Arrangement          | Cl. Isol. Rating | Dim. contact size |    |
|                      |                  | 20                | 16 |
| 8 - 3A               | I                | 3                 |    |
| 10 - 6               | I                | 6                 |    |
| 12 - 3               | II               |                   | 3  |
| 12 - 10              | I                | 10                |    |
| 14 - 5               | II               |                   | 5  |
| 14 - 12              | I                | 8                 | 4  |
| 14 - 15              | I                | 14                | 1  |
| 14 - 19              | I                | 19                |    |
| 16 - 8               | II               |                   | 8  |
| 16 - 23              | I                | 22                | 1  |
| 16 - 26              | I                | 26                |    |
| 18 - 11              | II               |                   | 11 |
| 18 - 32              | I                | 32                |    |
| 20 - 16              | II               |                   | 16 |
| 20 - 41              | I                | 41                |    |
| 22 - 21              | II               |                   | 21 |
| 22 - 55              | I                | 55                |    |
| 24 - 61              | I                | 61                |    |

| Alternate Insert Orientations |         |       |     |     |
|-------------------------------|---------|-------|-----|-----|
| Arrangement                   | Degrees |       |     |     |
|                               | W       | X     | Y   | Z   |
| 8 - 3A                        | 60      | (120) |     |     |
| 10 - 6                        | 90      |       |     |     |
| 12 - 3                        |         |       | 180 |     |
| 12 - 10                       | 60      | 155   | 270 | 295 |
| 14 - 5                        | 40      | 92    | 184 | 273 |
| 14 - 12                       | 43      | 90    |     |     |
| 14 - 15                       | 17      | 110   | 155 | 234 |
| 14 - 19                       | 30      | 165   | 315 |     |
| 16 - 8                        | 54      | 152   | 180 | 331 |
| 16 - 23                       | 158     | 270   |     |     |
| 16 - 26                       | 60      |       | 275 | 338 |
| 18 - 11                       | 62      | 119   | 241 | 340 |
| 18 - 32                       | 85      | 138   | 222 | 265 |
| 20 - 16                       | 238     | 318   | 333 | 347 |
| 20 - 41                       | 45      | 126   | 225 |     |
| 22 - 21                       | 16      | 135   | 175 | 349 |
| 22 - 55                       | 30      | 142   | 226 | 314 |
| 24 - 61                       | 90      | 180   | 270 | 324 |

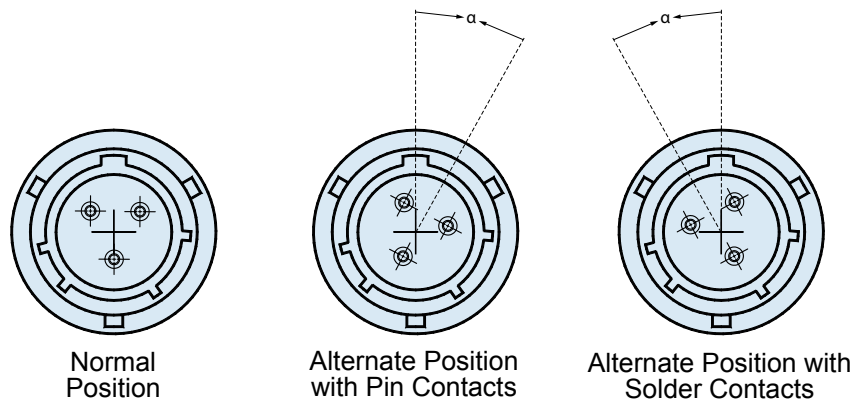

| MATERIALS                             |   |
|---------------------------------------|---|
| <b>SHELLS</b>                         | <b>INSERTS (Temperature Range)</b>                              |
| Aluminum Alloy<br>IAW QQ-A-591 Shells | High Insulation Synthetic Rubber<br>(Chloroprene): -55°C/+125°C |
| Stainless Steel<br>Coupling Pins      | <b>CRIMP CONTACTS</b>   |
| Stainless Steel Spring                | Copper Alloy with Gold Plating Over Nickel                      |

| STANDARD FINISH<br>(For QQ-A-591 Aluminum Shells) |   |
|---|---|
| <b>Requirements</b>                               | <b>Cadmium with Olive Drab Passivation<br/>IAW QQ-P-416</b> |
| Thermal Shock                                     | -55°C + 125°C   |
| Salt Spray After Thermal Shock                    | 500 hour  |
| Electrical Conductivity                           | Very Good   |
| Abrasion Resistance                               | Very Good   |

**VG95328 W**  
**Bayonet-Lock**  
**Straight Plug Connector with Thumb-Lock Lever,**  
**Grounding-Fingers and EMI/Shrinkboot Backshell**

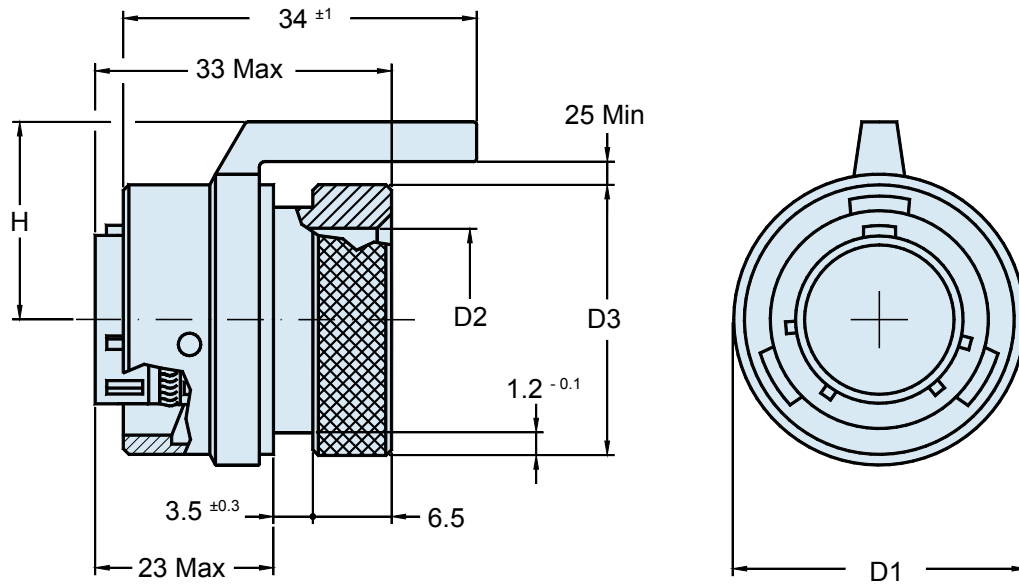
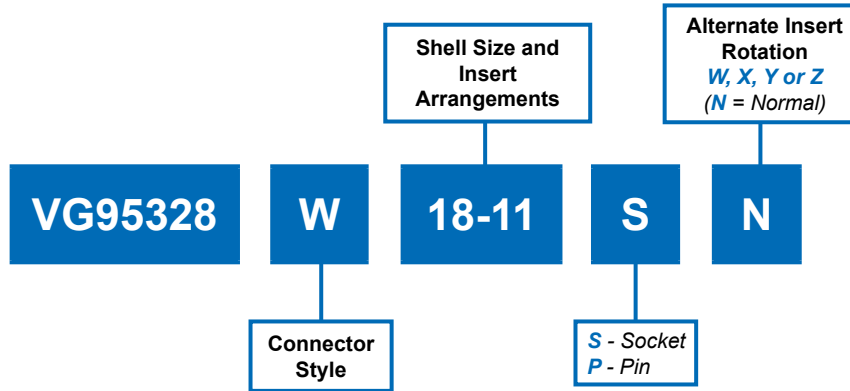

| Shell Size | D1<br>± 1 | D2<br>± 0.5 | D3<br>± 0.5 |       | H<br>± 1 | Max Weight<br>(g) |
|------------|-----------|-------------|-------------|-------|----------|-------------------|
|            |           |             |             | Limit |          |                   |
| 12         | 24        | 14.0        | 19.8        | -1.65 | 18       | 16                |
| 14         | 28        | 17.1        | 23.0        | -2.20 | 20       | 18                |
| 16         | 31        | 20.3        | 26.2        | -2.20 | 21       | 20                |

**VG95328 W**  
**Bayonet-Lock**  
**Straight Plug Connector with Thumb-Lock Lever,**  
**Grounding-Fingers and EMI/Shrinkboot Backshell**



VG95328  
Connectors

| Contact Arrangements |                  |                   |    |
|----------------------|------------------|-------------------|----|
| Arrangement          | Cl. Isol. Rating | Dim. contact size |    |
|                      |                  | 20                | 16 |
| 8 - 3A               | I                | 3                 |    |
| 10 - 6               | I                | 6                 |    |
| 12 - 3               | II               |                   | 3  |
| 12 - 10              | I                | 10                |    |
| 14 - 5               | II               |                   | 5  |
| 14 - 12              | I                | 8                 | 4  |
| 14 - 15              | I                | 14                | 1  |
| 14 - 19              | I                | 19                |    |
| 16 - 8               | II               |                   | 8  |
| 16 - 23              | I                | 22                | 1  |
| 16 - 26              | I                | 26                |    |
| 18 - 11              | II               |                   | 11 |
| 18 - 32              | I                | 32                |    |
| 20 - 16              | II               |                   | 16 |
| 20 - 41              | I                | 41                |    |
| 22 - 21              | II               |                   | 21 |
| 22 - 55              | I                | 55                |    |
| 24 - 61              | I                | 61                |    |

| Alternate Insert Orientations |         |       |     |     |
|-------------------------------|---------|-------|-----|-----|
| Arrangement                   | Degrees |       |     |     |
|                               | W       | X     | Y   | Z   |
| 8 - 3A                        | 60      | (120) |     |     |
| 10 - 6                        | 90      |       |     |     |
| 12 - 3                        |         |       | 180 |     |
| 12 - 10                       | 60      | 155   | 270 | 295 |
| 14 - 5                        | 40      | 92    | 184 | 273 |
| 14 - 12                       | 43      | 90    |     |     |
| 14 - 15                       | 17      | 110   | 155 | 234 |
| 14 - 19                       | 30      | 165   | 315 |     |
| 16 - 8                        | 54      | 152   | 180 | 331 |
| 16 - 23                       | 158     | 270   |     |     |
| 16 - 26                       | 60      |       | 275 | 338 |
| 18 - 11                       | 62      | 119   | 241 | 340 |
| 18 - 32                       | 85      | 138   | 222 | 265 |
| 20 - 16                       | 238     | 318   | 333 | 347 |
| 20 - 41                       | 45      | 126   | 225 |     |
| 22 - 21                       | 16      | 135   | 175 | 349 |
| 22 - 55                       | 30      | 142   | 226 | 314 |
| 24 - 61                       | 90      | 180   | 270 | 324 |

**Class L, U, and W Thumb-Lock versions not qualified to VG95328. Please consult factory for Glenair commercial equivalent VG95328 type Thumb-Lock connectors**

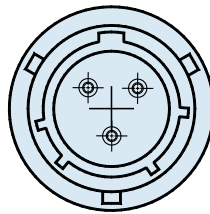

Normal Position

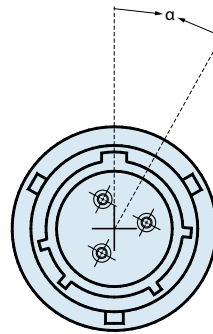

Alternate Position with Pin Contacts

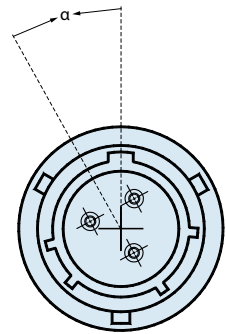

Alternate Position with Solder Contacts

| MATERIALS                             |   |
|---------------------------------------|---|
| <b>SHELLS</b>                         | <b>INSERTS (Temperature Range)</b>                              |
| Aluminum Alloy<br>IAW QQ-A-591 Shells | High Insulation Synthetic Rubber<br>(Chloroprene): -55°C/+125°C |
| Stainless Steel<br>Coupling Pins      | <b>CRIMP CONTACTS</b>   |
| Stainless Steel Spring                | Copper Alloy with Gold Plating Over Nickel                      |

| STANDARD FINISH<br>(For QQ-A-591 Aluminum Shells) |   |
|---|---|
| <b>Requirements</b>                               | <b>Cadmium with Olive Drab Passivation<br/>IAW QQ-P-416</b> |
| Thermal Shock                                     | -55°C + 125°C   |
| Salt Spray After Thermal Shock                    | 500 hour  |
| Electical Conductivity                            | Very Good   |
| Abrasion Resistance                               | Very Good   |

**VG95328 Z1 A, B, and C**  
**Receptacle Covers for Panel Attachment**  
**For Connectors A to H and P, R, S and T Only**

**VG95328**

**Z1**

**A**

**18**

Receptacle  
Cover

Lanyard Style  
**A** = Chain with  
Eyelet  
**B** = Rope with  
Eyelet  
**C** = Rope Sans  
Eyelet

Shell Size

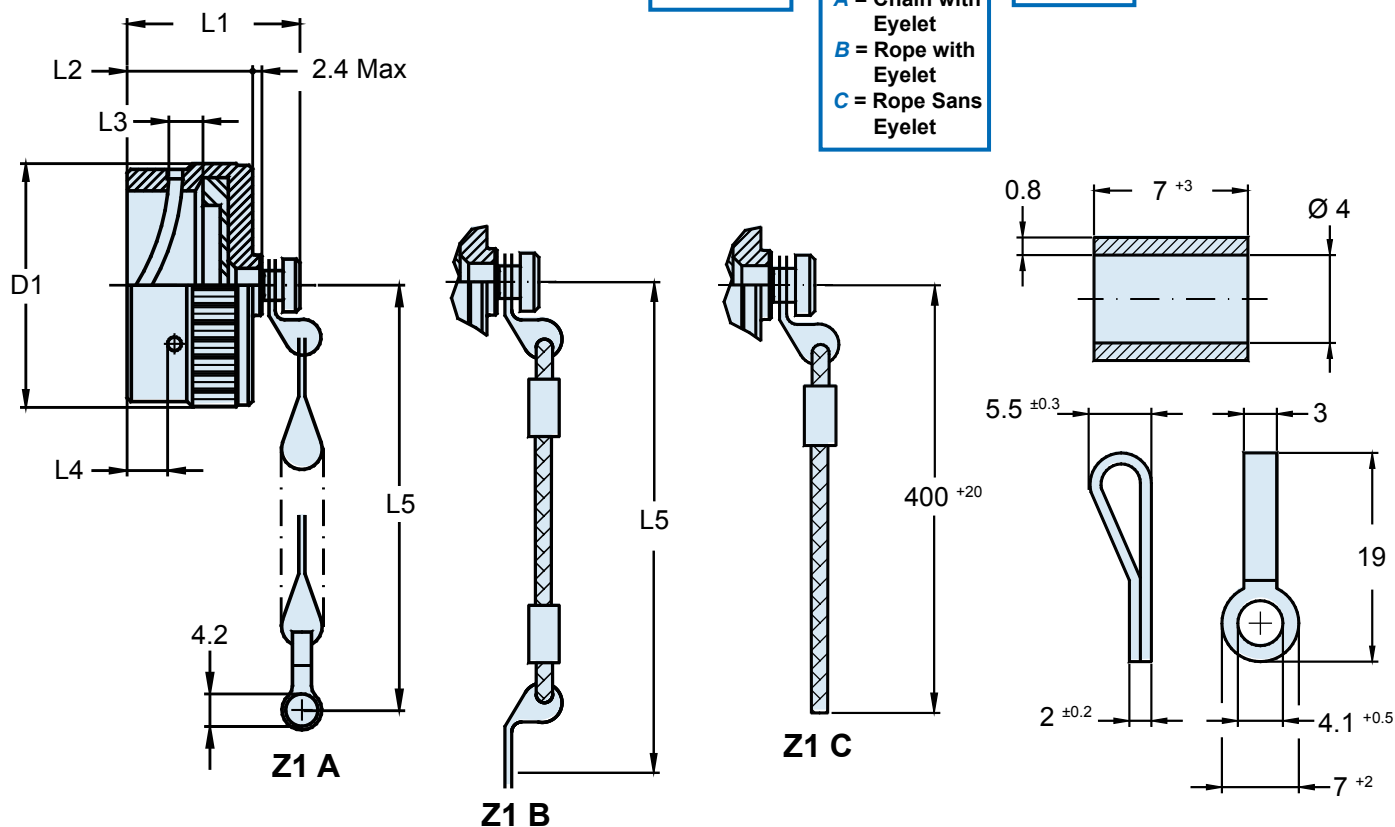

**TABLE I: DIMENSIONS**

| Shell size | D1<br>Max. | L1<br>Max. | L2<br>Max. | L3<br>+ 0.25<br>- 0.38 | L4<br>Max. | L5<br>+ 13<br>- 7 | Maximum<br>Weight in<br>Grams |
|------------|------------|------------|------------|------------------------|------------|-------------------|-------------------------------|
| 8          | 18.7       | 21.5       | 14.3       | 2.92                   | 3.78       | 77                | 17                            |
| 10         | 21.9       | 21.5       | 14.3       | 2.92                   | 3.78       | 77                | 17                            |
| 12         | 25.4       | 21.5       | 14.3       | 2.92                   | 3.78       | 89                | 25                            |
| 14         | 28.6       | 21.5       | 14.3       | 2.92                   | 3.78       | 89                | 25                            |
| 16         | 31.8       | 21.5       | 14.3       | 2.92                   | 3.78       | 89                | 29                            |
| 18         | 35.0       | 21.5       | 14.3       | 2.92                   | 3.78       | 89                | 29                            |
| 20         | 38.1       | 21.5       | 14.3       | 2.92                   | 3.78       | 102               | 33                            |
| 22         | 41.3       | 21.5       | 14.3       | 2.92                   | 3.78       | 102               | 36                            |
| 24         | 44.5       | 22.3       | 15.3       | 3.73                   | 2.21       | 102               | 42                            |



**VG95328 Z2 A, B, and C**  
**Plug Covers for Panel Attachment**  
**For Connectors J to N and U, V and W Only**



VG95328  
Accessories

**VG95328**

**Z2**

**A**

**18**

Plug  
Cover

Lanyard Style  
**A** = Chain with Eyelet  
**B** = Rope with Eyelet  
**C** = Rope Sans Eyelet

Shell Size

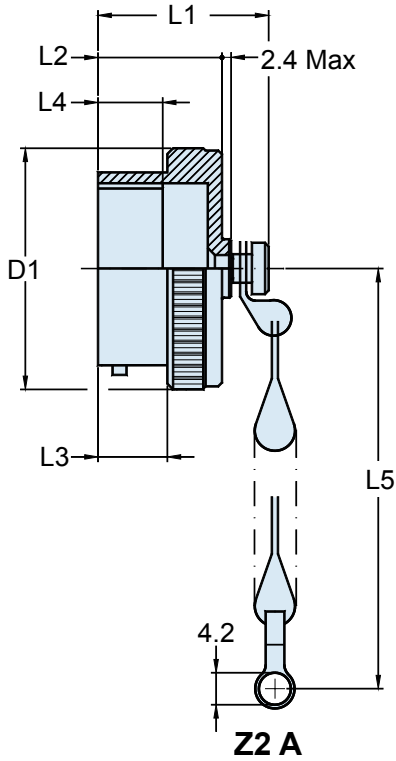

**Z2 A**

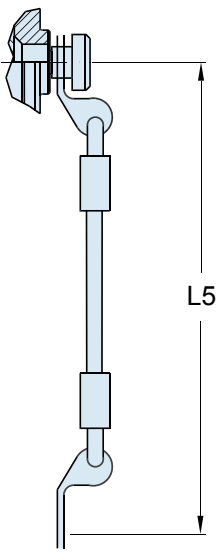

**Z2 B**

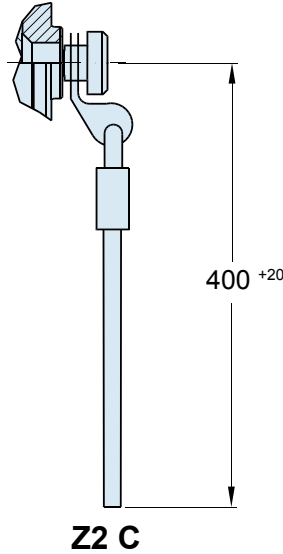

**Z2 C**

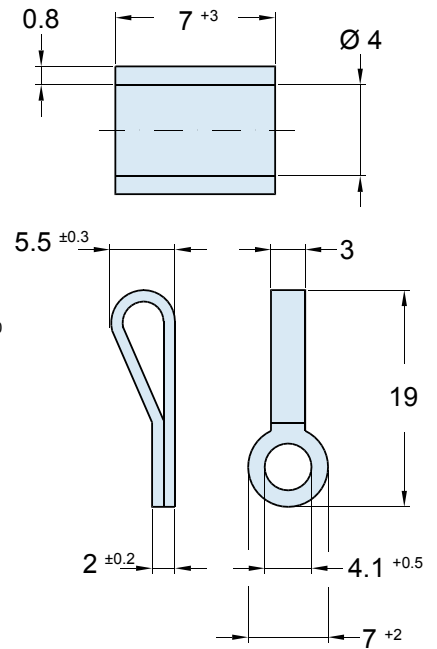

| TABLE I: DIMENSIONS |         |         |         |              |                 |             |                         |
|---------------------|---------|---------|---------|--------------|-----------------|-------------|-------------------------|
| Shell size          | D1 Max. | L1 Max. | L2 Max. | L3 + 0.8 - 0 | L4 + 0.25 - 0.5 | L5 + 13 - 7 | Maximum Weight in Grams |
| 8                   | 18.3    | 19.9    | 14.3    | 9.35         | 8.3             | 77          | 17                      |
| 10                  | 21.5    | 19.9    | 14.3    | 9.35         | 8.3             | 77          | 17                      |
| 12                  | 25.4    | 19.9    | 14.3    | 9.35         | 8.3             | 89          | 21                      |
| 14                  | 28.6    | 19.9    | 14.3    | 9.35         | 8.3             | 89          | 24                      |
| 16                  | 31.8    | 19.9    | 14.3    | 9.35         | 8.3             | 89          | 27                      |
| 18                  | 35.0    | 19.9    | 14.3    | 9.35         | 8.3             | 89          | 31                      |
| 20                  | 38.1    | 21.5    | 15.9    | 10.92        | 9.9             | 102         | 36                      |
| 22                  | 41.3    | 21.5    | 15.9    | 10.92        | 9.9             | 102         | 40                      |
| 24                  | 44.5    | 22.3    | 16.7    | 11.76        | 9.9             | 102         | 43                      |

**VG95328 Z3 C**  
**Receptacle Cover For Cable Attachment**  
**For Connectors D, E, F, S and T Only**

**VG95328**      **Z3**      **C**      **18**

Receptacle Cover      Lanyard Style  
 C = Rope with Connector Ring      Shell Size

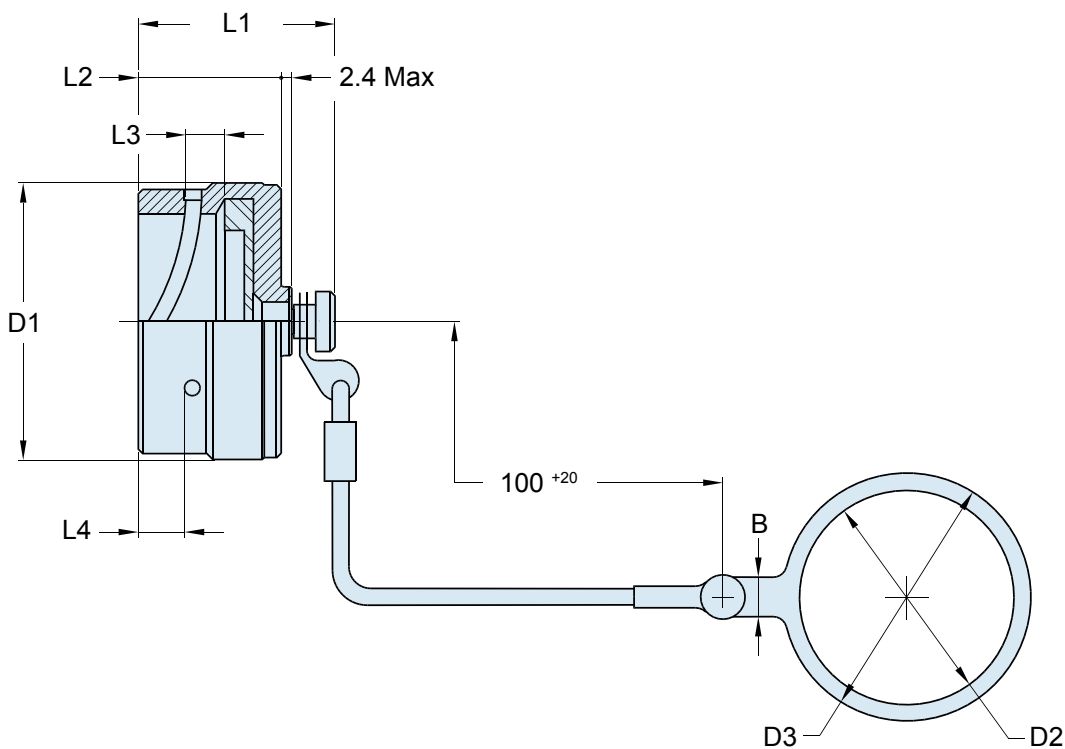

**TABLE I: DIMENSIONS**

| Shell size | B Min. | D2 Min. | D3 Max. | Maximum Weight in Grams |
|------------|--------|---------|---------|-------------------------|
| 8          | 5.94   | 14.68   | 20.62   | 17                      |
| 10         | 5.94   | 17.86   | 25.40   | 17                      |
| 12         | 5.94   | 22.63   | 30.18   | 25                      |
| 14         | 5.94   | 25.81   | 36.53   | 25                      |
| 16         | 5.94   | 28.98   | 39.67   | 29                      |
| 18         | 5.94   | 32.16   | 42.88   | 29                      |
| 20         | 5.94   | 35.33   | 46.02   | 33                      |
| 22         | 5.94   | 38.51   | 49.23   | 36                      |
| 24         | 5.94   | 41.68   | 52.37   | 42                      |

**VG95328 T07 A and B**  
**Conductive and Non-Conductive Gaskets**  
**For Connectors A, B, C, H, P and R Only**

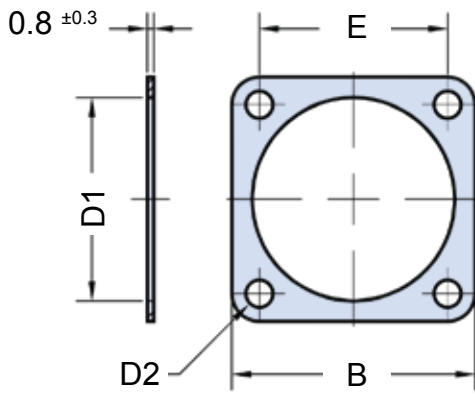
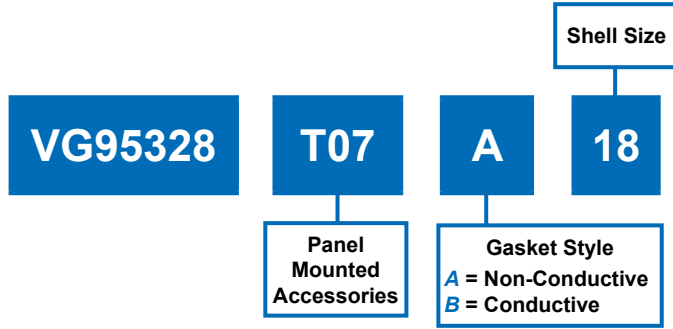

**VG95328 T07 A**  
**Non-Conductive**

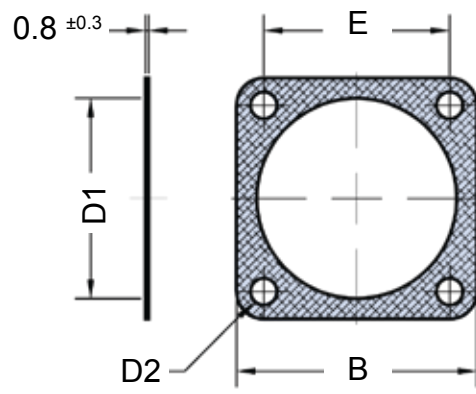

**VG95328 T07 B**  
**Conductive**

**TABLE I: DIMENSIONS**

| Shell size | B Max. | D1 +1 -0 | D2 Min. | E ± 0.3 | Maximum Weight in Grams |
|------------|--------|----------|---------|---------|-------------------------|
| 8          | 22.7   | 12.7     | 3.1     | 15.1    | 2                       |
| 10         | 25.8   | 15.9     | 3.1     | 18.3    | 2                       |
| 12         | 28.2   | 19.0     | 3.1     | 20.6    | 2                       |
| 14         | 30.6   | 22.2     | 3.1     | 23.0    | 2                       |
| 16         | 33.0   | 25.4     | 3.1     | 24.6    | 2                       |
| 18         | 35.4   | 28.6     | 3.1     | 27.0    | 2                       |
| 20         | 38.5   | 31.7     | 3.1     | 29.4    | 2                       |
| 22         | 41.7   | 34.9     | 3.1     | 31.8    | 2                       |
| 24         | 44.9   | 38.1     | 4.2     | 34.9    | 2                       |

# VG95328 T07 C Dummy Storage Receptacle Closed Back

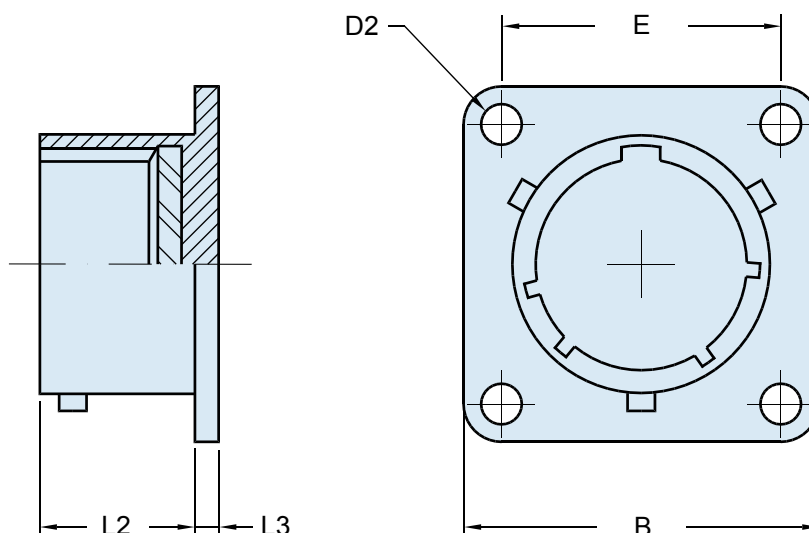
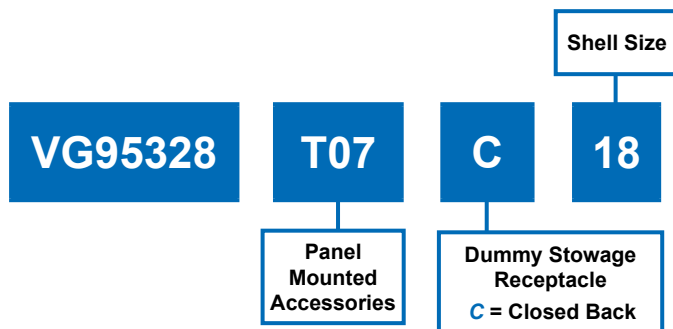

| TABLE I: DIMENSIONS |           |            |             |            |            |                               |
|---------------------|-----------|------------|-------------|------------|------------|-------------------------------|
| Shell size          | B<br>Max. | D2<br>Min. | E<br>± 0.15 | L2<br>Max. | L3<br>Max. | Maximum<br>Weight in<br>Grams |
| 8                   | 21.03     | 2.9        | 15.08       | 12.5       | 2.0        | 8                             |
| 10                  | 24.23     | 2.9        | 18.26       | 12.5       | 2.0        | 10                            |
| 12                  | 26.59     | 2.9        | 20.62       | 12.5       | 2.0        | 12                            |
| 14                  | 28.98     | 2.9        | 23.01       | 12.5       | 2.0        | 14                            |
| 16                  | 31.34     | 2.9        | 24.61       | 12.5       | 2.0        | 16                            |
| 18                  | 33.73     | 2.9        | 26.97       | 12.5       | 2.0        | 18                            |
| 20                  | 36.90     | 2.9        | 29.36       | 15.0       | 2.8        | 20                            |
| 22                  | 40.08     | 2.9        | 31.75       | 15.0       | 2.8        | 25                            |
| 24                  | 43.25     | 3.6        | 34.92       | 15.0       | 2.8        | 30                            |

**VG95328 T07 D**  
**Dummy Stowage Receptacle**  
**Open Back**



VG95328  
 Accessories

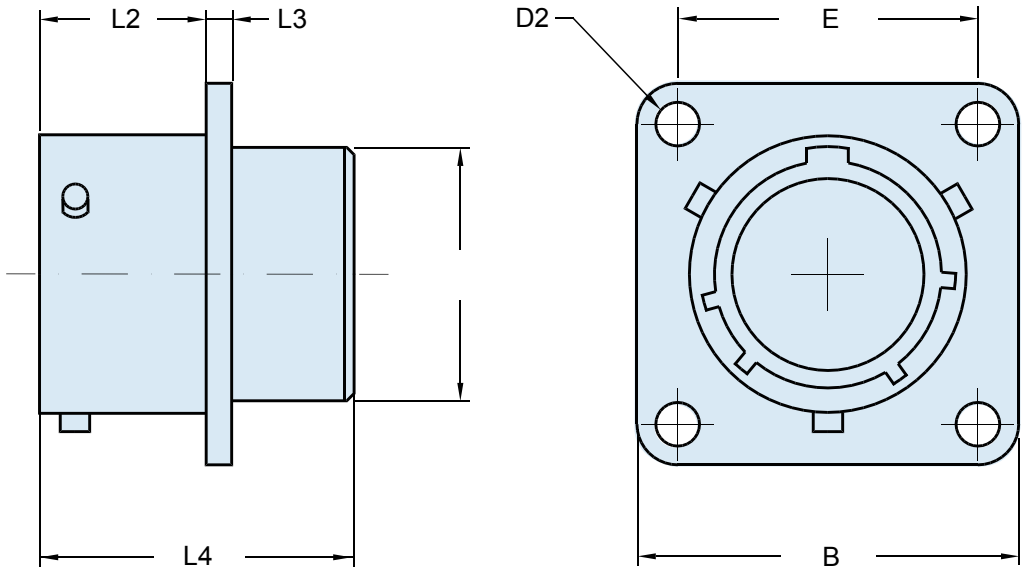
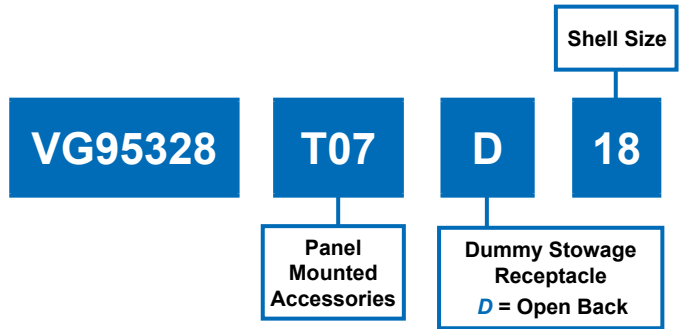

**TABLE I: DIMENSIONS**

| Shell size | B<br>Max. | D2<br>Min. | D3<br>+ 0.8<br>- 0.6 | E<br>± 0.15 | L2<br>Max. | L3<br>Max. | L4<br>Max. | Maximum<br>Weight in<br>Grams |
|------------|-----------|------------|----------------------|-------------|------------|------------|------------|-------------------------------|
| 8          | 21.03     | 2.9        | 11.2                 | 15.08       | 10.94      | 2.0        | 24.3       | 6                             |
| 10         | 24.23     | 2.9        | 14.3                 | 18.26       | 10.94      | 2.0        | 24.3       | 7                             |
| 12         | 26.59     | 2.9        | 17.5                 | 20.62       | 10.94      | 2.0        | 24.3       | 10                            |
| 14         | 28.98     | 2.9        | 20.7                 | 23.01       | 10.94      | 2.0        | 24.3       | 12                            |
| 16         | 31.34     | 2.9        | 23.9                 | 24.61       | 10.94      | 2.0        | 24.3       | 14                            |
| 18         | 33.73     | 2.9        | 27.0                 | 26.97       | 10.94      | 2.0        | 24.3       | 17                            |
| 20         | 36.90     | 2.9        | 30.2                 | 29.36       | 14.12      | 2.6        | 28.3       | 21                            |
| 22         | 40.08     | 2.9        | 33.4                 | 31.75       | 14.12      | 2.6        | 28.3       | 25                            |
| 24         | 43.25     | 3.6        | 36.6                 | 34.92       | 14.96      | 2.6        | 28.9       | 27                            |

# To Most People It's Just a Connector



## To Glenair It's a Promise

**M**ost customers have a simple expectation when they go shopping for safety-critical interconnect components: They want fast and accurate service. Glenair addresses this most basic customer requirement in several different ways. First and foremost, by providing immediate access to our technical information and product documentation: whether you prefer an office visit, the telephone, the Internet, a CD or a printed catalog, Glenair is ready with answers to your most complex questions and design challenges. Secondly, Glenair stocks thousands of popular catalog products for those situations

when even a two or three week lead-time is just too long. We stock over 65,000 interconnect components—bagged and tagged and ready for immediate shipment. And for those situations when a customized solution is required, our engineers are fully versed in all aspects of interconnect system design: from shielding against EMI, to reducing weight and connector package size, to stopping corrosion and other forms of environmental damage.

You have a simple expectation: fast and accurate service. At Glenair, we're ready to give you exactly that. It's a promise.



1211 Air Way

Glendale, California 91201-2497

Telephone: 818-247-6000 · Facsimilie: 818-500-9912 · EMail: [sales@glenair.com](mailto:sales@glenair.com)

United States · United Kingdom · Germany · Nordic · France · Italy · Spain · Japan

[www.glenair.com](http://www.glenair.com)

# The world's broadest selection of interconnect products—in stock and ready for immediate same-day shipment

## Glenair's World of Interconnect Solutions

A complete overview of Glenair's innovative range of interconnect products and services, including Military Standard and commercial equivalent connectors and accessories.

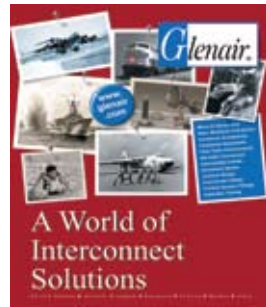

## Micro-D Twistpin Connectors and Accessories

Glenair offers both Military Standard 83513 Micro-D connectors as well as COTS selections, backshells, mounting hardware and more. Our TwistPin contact provides superior performance.



## EMI/EMP Filter Connectors

MIL-DTL-38999 type EMI/EMP filter connectors, as well as other Military Standard and commercial electromagnetic shielding technologies. Also includes Glenair Series 80 "Mighty Mouse" filter products.



## Fiber Optic Interconnect Solutions

Tactical fiber optic connectors, cables, and termini for airframe, shipboard, and military ground vehicles. Catalog features Glenair's innovative high-density (GHD) connector system for reduced size and weight applications.



Available now: **Glenair's Interconnect Product Guide CD**, featuring our entire library of Glenair catalogs and data sheets.



In addition to over a dozen product line catalogs, the CD includes a powerful part number development program that takes all the pain and confusion out of ordering interconnect components. An easy-to-use inventory search program provides ready access to 60,000 MIL-STD and commercial part numbers.

## Composite Thermoplastic Interconnect Solutions

Glenair is the world's leading manufacturer of composite interconnect solutions. We are the 'go-to' supplier for advanced composite technologies for commercial and military interconnect applications.

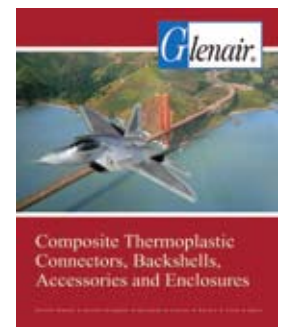

## Military Standard Connector Accessories

If the MS connector accessory you need isn't in here – it doesn't exist. Search this easy-to-use catalog by accessory type or Mil-Spec slash number, then place your order against Glenair's 60,000 part number same-day inventory.



## Series 80 "Mighty Mouse" Connectors and Cables

Glenair's revolutionary connector series that reduces interconnect system size and weight by 50% compared to standard MIL-DTL-38999 connectors. Now used on hundreds of mission-critical military and commercial applications.

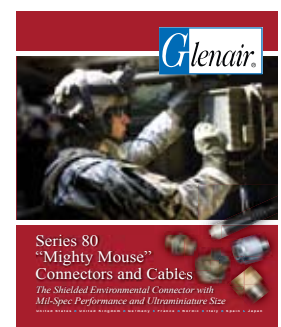

Visit us at [www.glenair.com](http://www.glenair.com) and use the literature order form for immediate catalog fulfillment

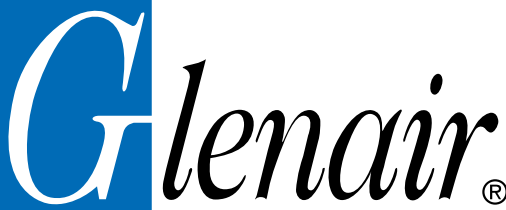

# A World of Interconnect Solutions

## Glenair, Inc.

1211 Air Way • Glendale, California • 91201-2497  
Telephone: 818-247-6000 • Fax: 818-500-9912 • sales@glenair.com  
[www.glenair.com](http://www.glenair.com)

---

**Glenair Industrial Power and  
Signal Connector Group** Telephone: 203-741-1115  
25 Village Lane Facsimile:  
Wallingford, CT 203-741-0053  
06492 sales@glenair.com

---

**Glenair UK Ltd** Telephone: 44-1623-638100  
40 Lower Oakham Way Facsimile:  
Oakham Business Park 44-1623-638111  
P.O. Box 37, Mansfield sales@glenair.co.uk  
Notts, NG18 5BY England

---

**Glenair Microway Systems** Telephone: 847-679-8833  
7000 North Lawndale Avenue Facsimile:  
Lincolnwood, IL 847-679-8849  
60712

---

**Glenair Nordic AB** Telephone: 46-8-50550000  
Gustav III : S Boulevard 46 Facsimile:  
S - 169 27 Solna 46-8-50550001  
Sweden sales@glenair.se

---

**Glenair Electric GmbH** Telephone: 49-6171-5905-0  
Siemensstrasse 9 Facsimile:  
D-61449 Steinbach 49-6171-5905-90  
Germany germany@glenair.com

---

**Glenair Iberica** Telephone: 34-925-89-29-88  
C/ La Vega, 16 Facsimile:  
45612 Velada 34-925-89-29-87  
Spain sales@glenair.es

---

**Glenair Italia S.R.L.** Telephone: 39-02-91082121  
Via Santi, 1 Facsimile:  
20037 Paderno Dugnano 39-02-99043565  
Milano, Italy sales-italia@glenair.it

---

**Glenair France SARL** Telephone: 33-5-34-40-97-40  
7, Avenue Parmentier Facsimile:  
Immeuble Central Parc #2 33-5-61-47-86-10  
31200 Toulouse sales@glenair.fr  
France

