

## Introduction

RP5 series are 14 pin circular connectors are used mainly for connection among video cameras, decks, tuners, etc. They have a "push-pull" lock system and have a light and robust plastic body.

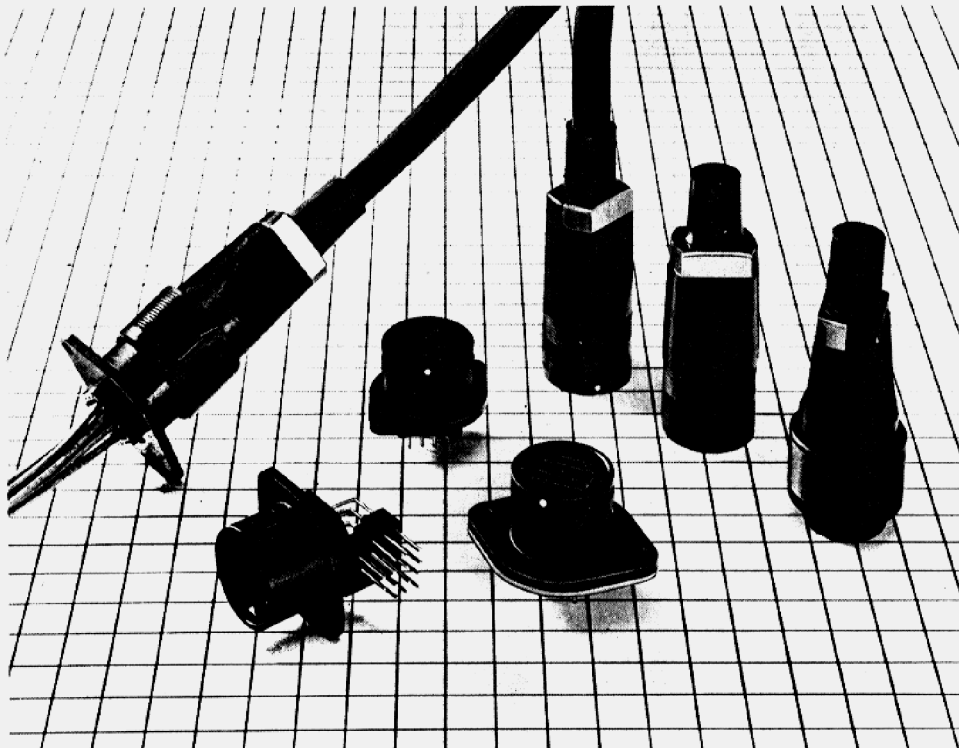

## Features

- 1. EASY "PUSH-PULL" OPERATION**  
One-touch "push-pull" coupling mechanism assures easy and quick connecting and disconnecting.
- 2. POLARIZATION**  
Positive connection to the specified position is guided by multiple keys.
- 3. PROTECTION OF CONNECTOR PIN**  
Connector pins are arranged in a deep location in order to prevent bending of contacts due to handling.
- 4. THREE TYPES OF CONTACTS**  
Crimp contacts, straight dip solder contacts and right angle dip solder contacts are available for the receptacles, and may be selected to correspond to the application.
- 5. SIMPLE AND REFINED APPEARANCE**  
The external form is simple and slim, and the frosted black appearance looks well with any equipment.

## Material and Finish

Part name	Material	Finish
Molding and connector body	UL94V-0 Glass-filled polycarbonate	Black
Pin contact	Phosphor bronze	Silver plating
Socket contact	Phosphor bronze	Silver plating

## Ordering Information

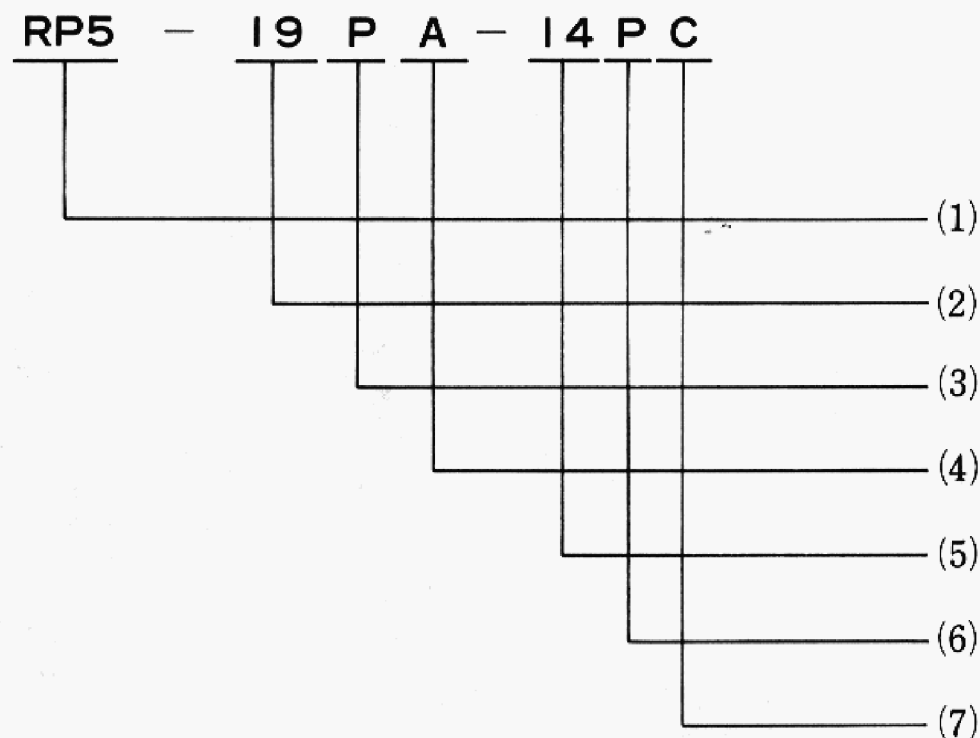

1. **RP5:** Series name.
2. **19:** Shell size
3. **P:** Shell Type  
P : Plug  
R : Receptacle  
J : Jack
4. **A:** Distinction is made by A, B, C ... if types vary for the same connector configuration.
5. **14:** No. of pin
6. **P:** Type of pin  
P: Male pin  
S: Female pin
7. **C:** The method of connection of terminals or the terminal configuration is identified by an alphabetic letter.

# Plug

(Crimp type)

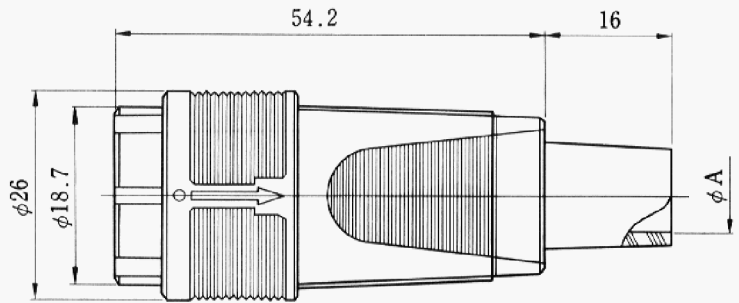
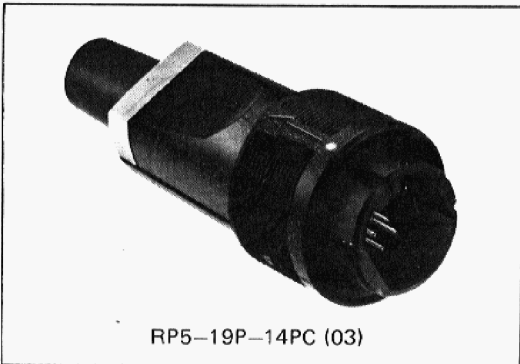

Part No.	mm (inch)	
	$\phi A$	
RP5-19P-14PC(03)	9.2 (0.362)	
RP5-19P-14PC(05)	6.8 (0.268)	
RP5-19PA-14PC(01)	6.0 (0.236)	
RP5-19PB-14PC	5.7 (0.224)	

# Receptacle

(Crimp type)

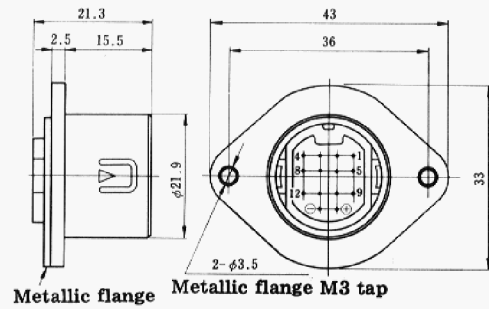
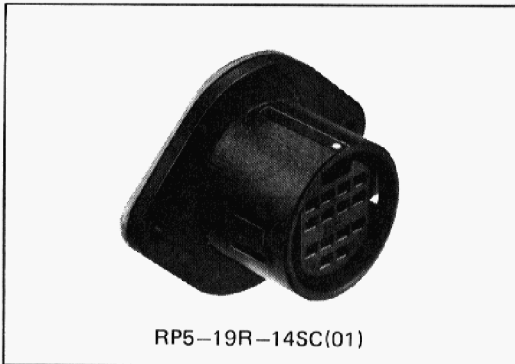

Part No.	Remarks
RP5-19RA-14SC(01)	
RP5-19R-14SC(01)	Without metallic flange

Remarks: Refer to page 179 for mounting hole size.

(Crimp type)

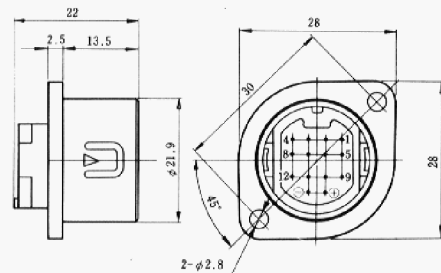
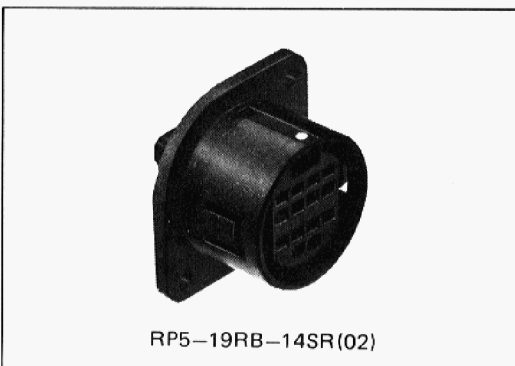

Part No.
RP5-19RB-14SR(02)

Remarks: Refer to page 179 for mounting hole size.

# Receptacle

(Straight dip type)

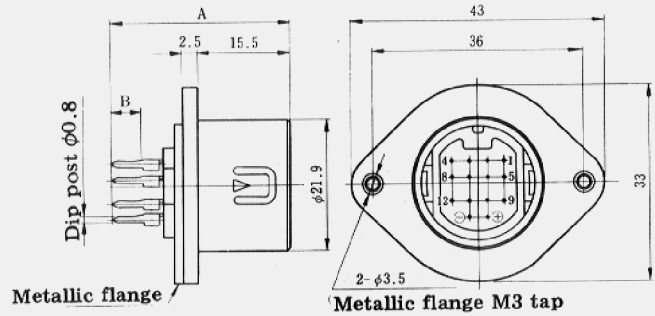
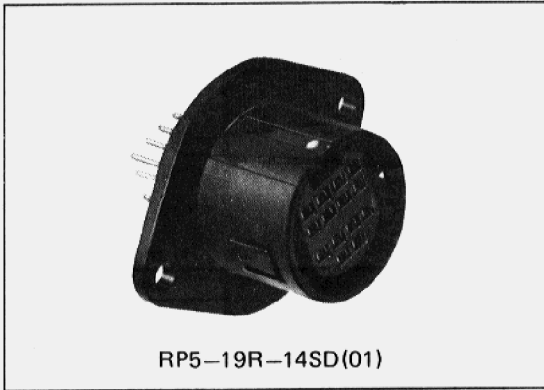

mm (inch)

Part No.	A	B	Remarks
RP5-19R-14SD(01)	33.3 (1.311)	8.3 (0.327)	Without metallic flange
RP5-19RA-14SD(01)	33.3 (1.311)	8.3 (0.327)	
RP5-19RA-14SE (01)	29 (1.142)	3.8 (0.327)	
RP5-19R-14SE	29 (1.142)	3.8 (0.150)	Without metallic flange
RP5-19RB-14SF	25.9 (1.020)	3.8 (0.150)	Without metallic flange Dip post size 0.3x0.7

Remarks: Refer to page 179 for mounting hole size.

(Right Angle dip type)

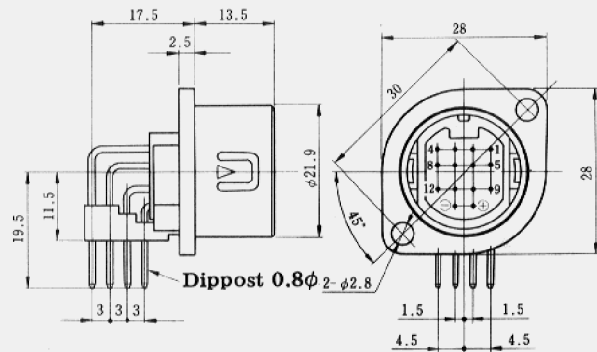
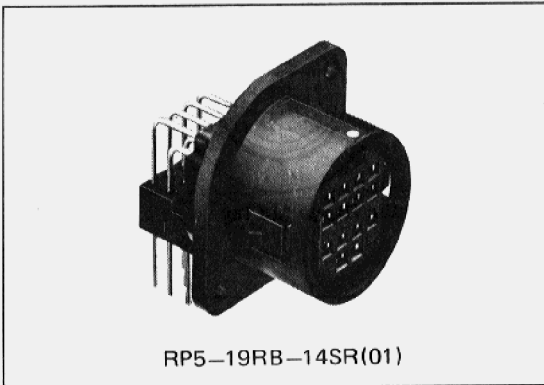

Part No.
RP5-19RB-14SR(01)

Remarks: Refer to page 179 for mounting hole size.

# Jack

(Crimp type)

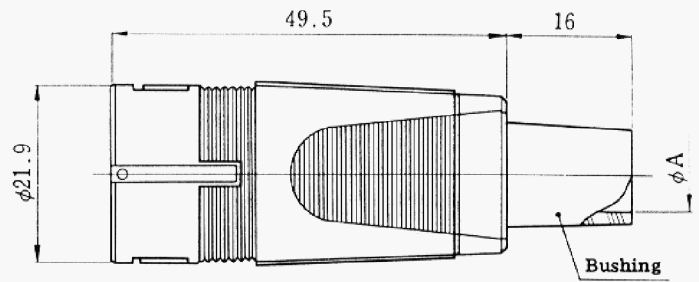
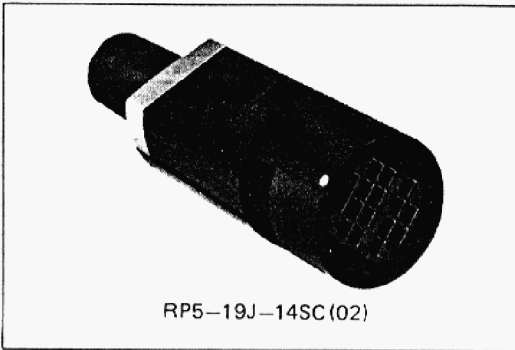

Part No.	mm (inch)
	$\phi A$
RP5-19J-14SC(02)	9.2 (0.362)
RP5-19J-14SC(01)	6.8 (0.268)
RP5-19J-14SC(03)	Without bushing
RP5-19JB-14SC	5.7 (0.224)

## Mounting Cutout

RP5-19R and RP5-19RA type

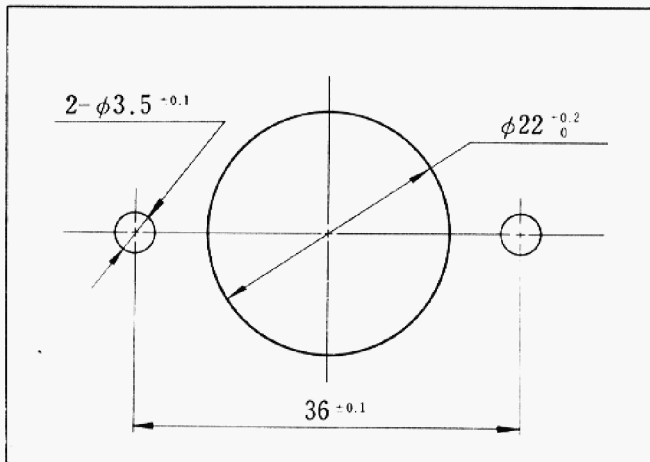

RP5-19RB type

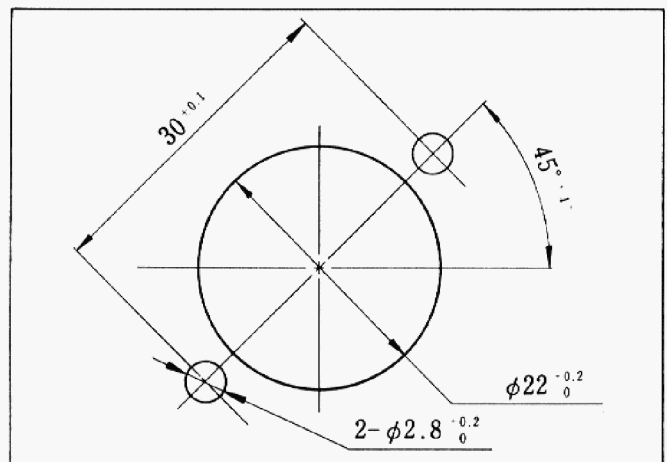

Part No.
RP5-19R-14SC(01)
RP5-19R-14SD(01)
RP5-19R-14SE
RP5-19RA-14SC(01)
RP5-19RA-14SD(01)
RP5-19RA-14SE(01)

Part No.
RP5-19RB-14SR(01)
RP5-19RB-14SR(02)
RP5-19RB-14SF

Note 1: Drawings indicate views from the panel surface side, and fitting guides of flange system are located in upper portions

Note 1: With a receptacle of flange system a connector is inserted from the back side of the panel. Therefore, the maximum allowable panel thickness is 4 mm.



# Contact

## Male Pin

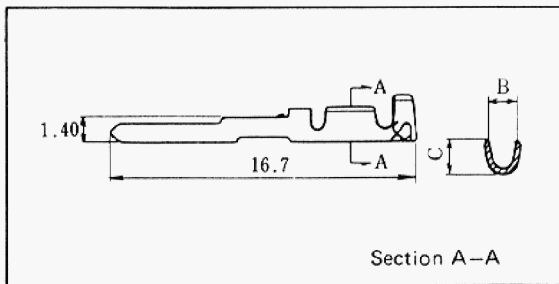

mm (inch)					
Type	Part No.	B	C	Applicable wire	Packing
Bulk contact	RM-PC-112	1.6 (0.063)	2 (0.079)	AWG #20 ~ #24	100 pin per bag
	RM-PC-122	1.45 (0.057)	1.5 (0.059)	AWG #24 ~ #28	
Chain contact	RM-PC-212	1.6 (0.063)	2 (0.079)	AWG #20 ~ #24	8,000 pin per reel
	RM-PC-222	1.45 (0.057)	1.5 (0.059)	AWG #24 ~ #28	

## Female Pin

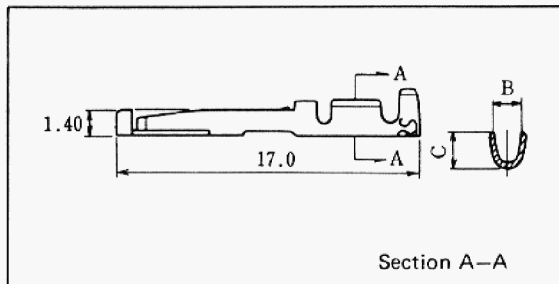

mm (inch)					
Type	Part No.	B	C	Applicable wire	Packing
Bulk contact	RM-SC-112	1.6 (0.063)	2 (0.079)	AWG #20 ~ #24	100 pin per bag
	RM-SC-122	1.45 (0.057)	1.5 (0.059)	AWG #24 ~ #28	
Chain contact	RM-SC-212	1.6 (0.063)	2 (0.079)	AWG #20 ~ #24	8,000 pin per reel
	RM-SC-222	1.45 (0.057)	1.5 (0.059)	AWG #24 ~ #28	

Note: 100 bulk contacts are contained per bag, and 8,000 chain contacts are provided per reel.

## Tools

Type	Part No.	Applicable wire
Hand Crimp Tool	RM-TC-11	AWG #20 ~ #24
	RM-TC-12	AWG #24 ~ #28
Auto Crimp Tool	CM-103	————
Extraction Tool	RM-TP	————

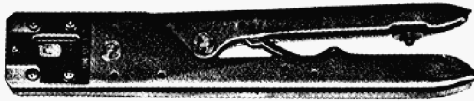

Hand Crimping Tool



Extraction Tool

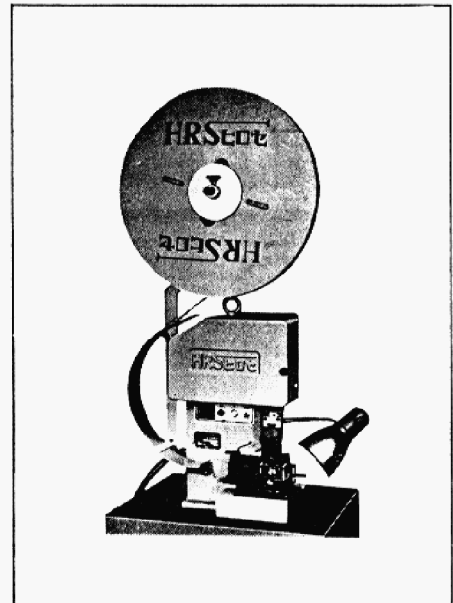

Auto Crimping Tool CM-103

## Assembling Procedure

### Plug

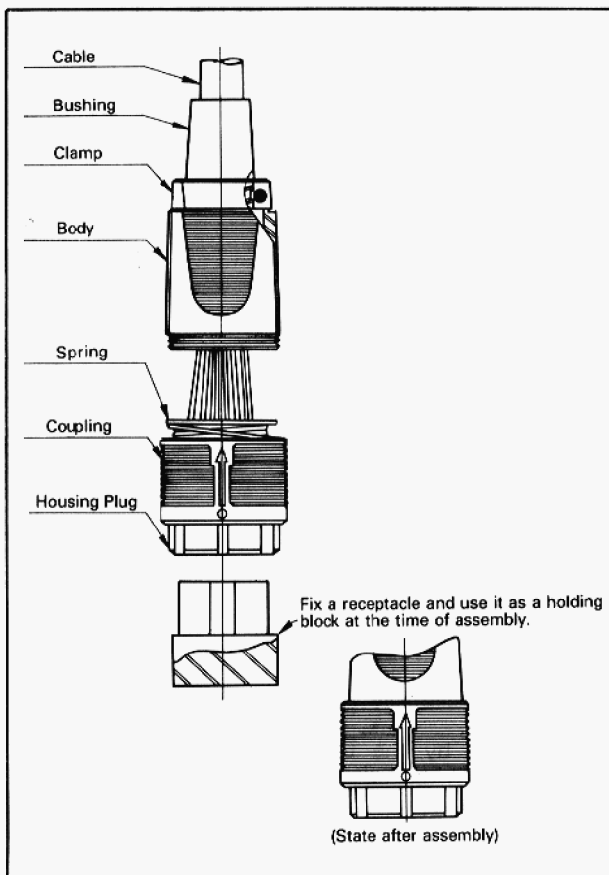

1. Fit the bushing in advance on wires having ends suitably treated, and then connect wires to terminals by crimp.
2. Then fit the connector body and coupling in this order on wires, and then mount crimped contacts into the plug housing.
3. Fix the plug housing by means of a holding block, and fasten the connector body. (Recommendable tightening torque 20 ~ 40 kg/cm) The state after assembly is as shown.
4. Fix the cord clamp by screws (about 2 kg/cm), and the work is completed.

## Jack

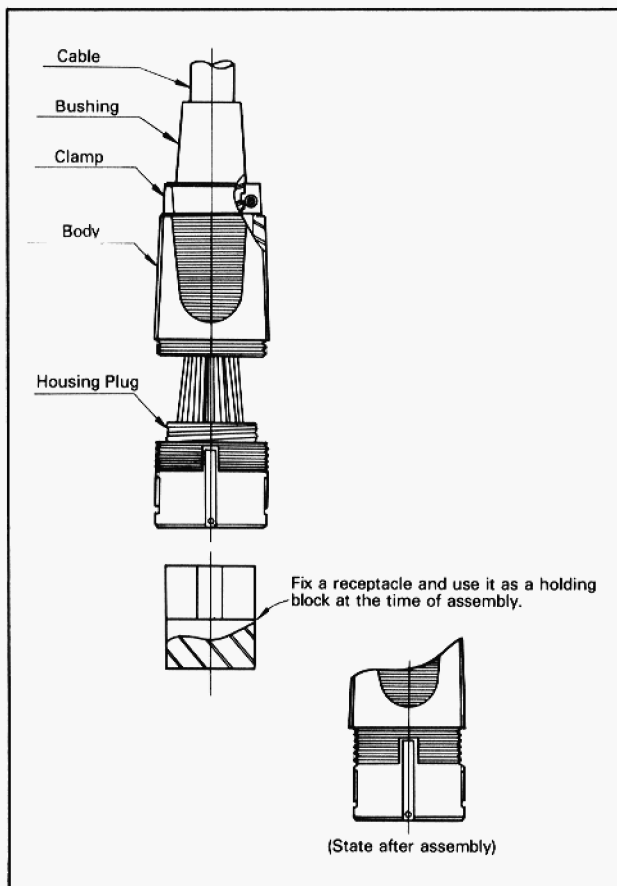

1. Fit the bushing in advance on wires having suitably treated ends and connect wires to terminals by crimp, in the manner equal to that of a plug.
2. The fit the connector body on wires, and mount crimped contacts into the socket housing.
3. Fix the socket housing to the holding block, and fasten the connector body. (Recommendable tightening torque 20 ~ 40 kg/cm) The state after assembly is as shown.
4. Fix the cord clamp by screws (about 2 kg/cm), and the work is completed.

## Contact Arrangement

Contact arrangement	
No. of pins	14
Withstanding voltage	AC 900V for 1 minute
Current rating	(when AWG #20 wires are used)
Insulation resistance	1000M $\Omega$ Min. at DC 500V
Contact resistance	7m $\Omega$ Max. at DC 1A
Applicable cable	AWG #20 ~ 24 (large barrel) AWG #24 ~ 28 (small barrel)

- Remarks: 1. The figure indicates a view from the fitting face side (plug's wire connecting side) of the receptacle and jack.
2. The withstanding voltage is indicated by the test voltage value. For normal use, 1/3 of the test voltage value should not be exceeded.