

UTS Series

8E2/8D2

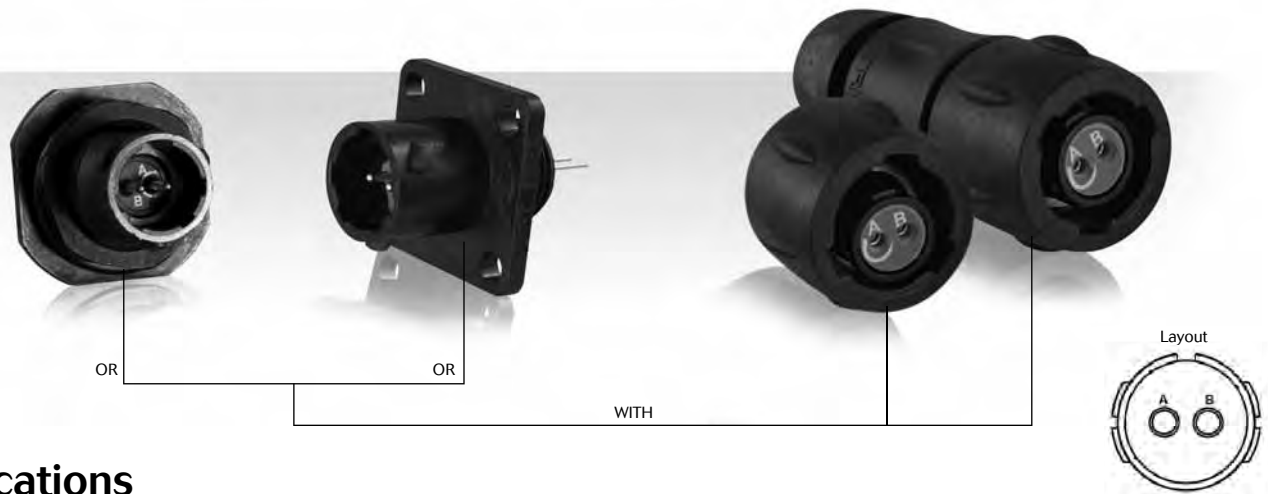

Specifications

Contact type	Connector type	Backshell	Part number	
			Male insert	Female insert
Hand solder electrical contacts loaded	Square flange receptacle	Without (Fig.1)	UTS08E2P	UTS08E2S
	Plug	Without (Fig.6)	UTS68E2P	UTS68E2S
		Cable gland (Fig.7)	UTS6JC8E2P	UTS6JC8E2S
	Jam nut receptacle	Without (Fig.3)	UTS78E2P	UTS78E2S
PCB contacts loaded	Square flange receptacle	Without (Fig.2)	UTS08D2P	UTS08D2S
	Jam nut receptacle with stand off and with hold down clips	Without (Fig.5)	UTS78D2P32	UTS78D2S32
	Jam nut receptacle with stand off and without hold down clip	Without (Fig.4)	UTS78D2P	UTS78D2S

Sealed unmatred



Dimensions

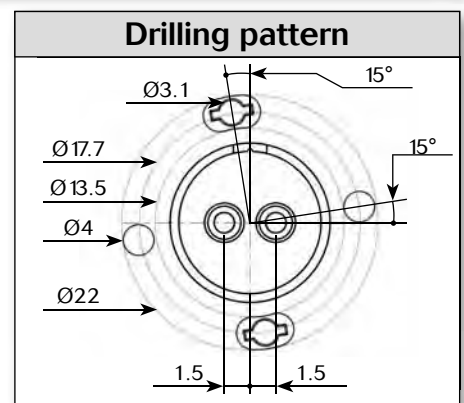
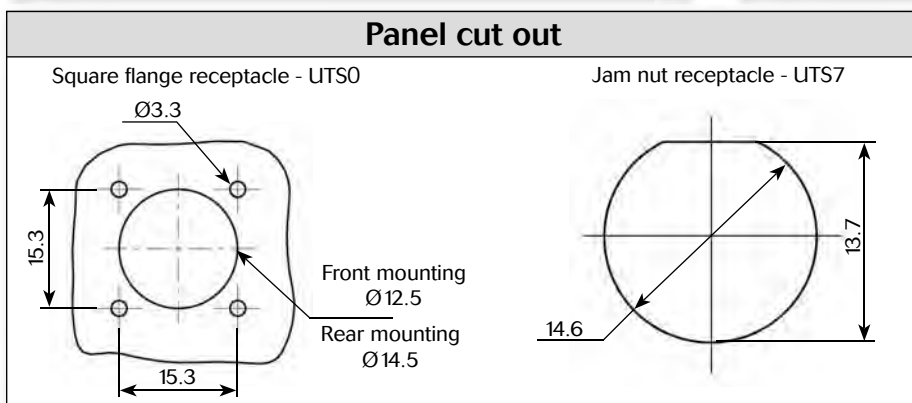
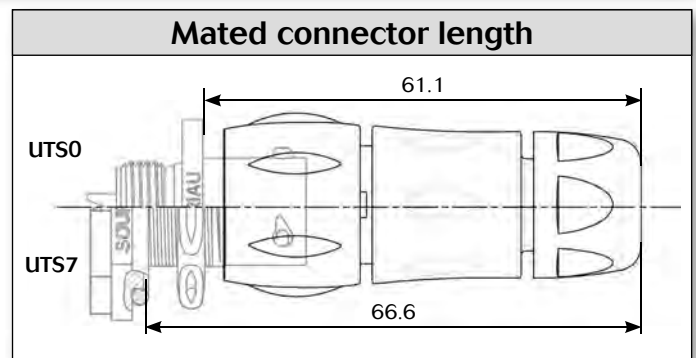
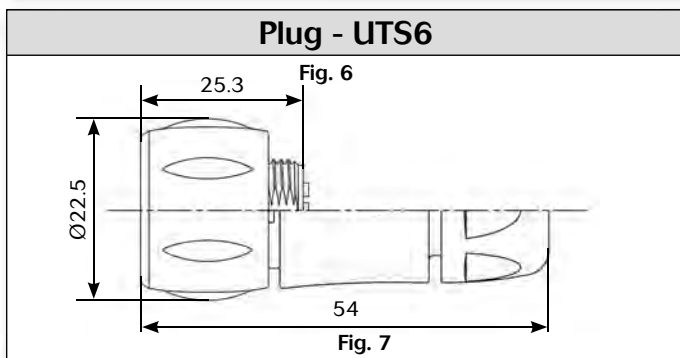
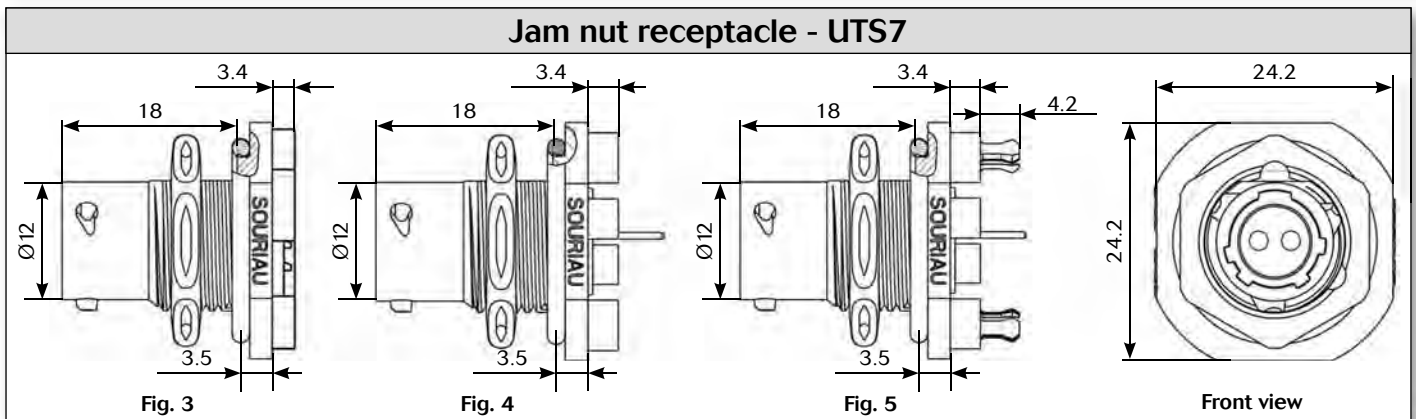
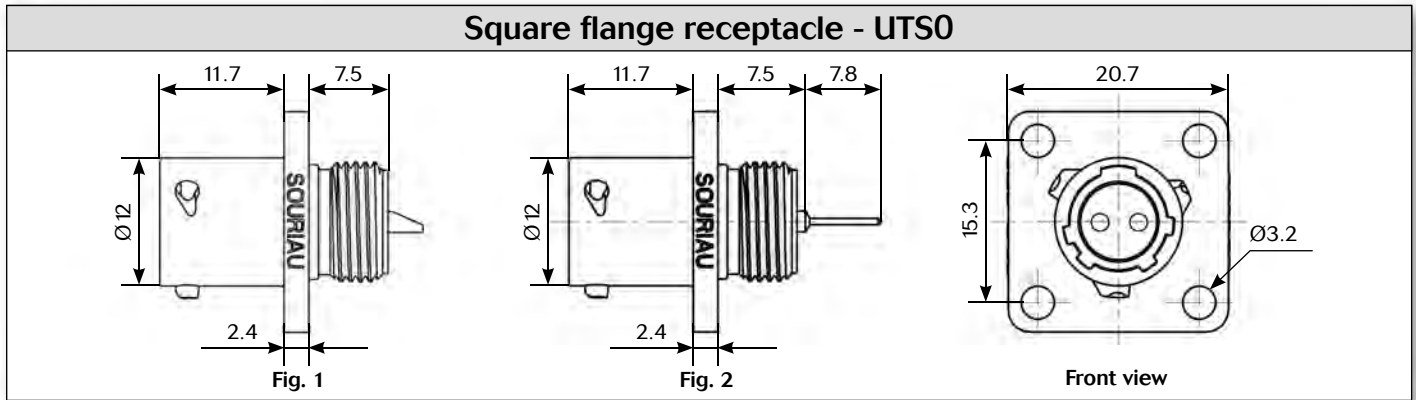

Note: all dimensions are in mm



Accessories

Jam nut sealing caps

Part number	Part number
UTS8DCG	UTS8DCGR

Metal terminal

Square flange sealing cap

Part number
UTS8DCGE

Metal terminal

Plug protective cap

Part number
UTS68C

IP40

Plastic protective cap

Part numbers	
Receptacle cap	Plug cap
85005585A	85005594

Gasket

Part numbers / neoprene
UTFD11B

Electrical characteristics

UL
7A 250V UL94 HB

CSA
7A 250V UL94 HB

IEC
7A 32V 1.5kV 3

