

HARSH ENVIRONMENTS RATCHET COUPLING M SERIES CONNECTOR



Rapid ratchet coupling mechanism

The M Series connector offers a new innovative design for motorsport applications and military systems. Made of high-strength aluminum, this connector is one of the lightest and most compact of the LEMO product line. A one-grip ratchet screw system enables quick and secure coupling of the connectors. The optional arctic grip makes it easy to manipulate the connector while wearing gloves or when the connector is located in a difficult to access area.

Features

- Ratchet-coupling mechanism
- Quick mating: 1/2 turn to seat
- Compact design for space savings
- Lightweight
- Oil and fuel resistant
- High vibration and shock resistance
- 360° shielding for full EMC protection
- Sealed to IP68 when mated
- Color coded keying options
- Requires a greater force to unmate than to mate
- Scoop proof
- Reverse sex configurations available



Technical Characteristics

Characteristics	Value	Standard
Endurance	3000 cycles	IEC 60512-5 test 9a
Operating temperature	-50°C/+200°C	-
Resistance to vibration	10-2000Hz, 15g	IEC 60512-4 test 6d
Shock resistance	100g, 6ms	IEC 60512-6 test 6c
Salt spray corrosion test	144h	IEC 60512-6 test 11f
Protection index (at 2m, 15 hr.)	IP68	IEC 60529
Gunfire vibration	satisfied	MIL STD-810-E

Material and treatment

Characteristics	Value	Surface treatment
Outershell, coupling nut	Aluminum (AA 6262A)	Ni (5 µm) ¹⁾
Earthing crown	Bronze (UNS C 54400)	Au (1.5 µm)
Ratchet	PEEK graphite	-
Insulator	PEEK	-
Contacts	Brass/Bronze	Ni (3 µm) + Au (1 µm)
Gaskets	FPM + FVMQ	-
Sealing resin	Epoxy	-

Note: 1) Anthracite color.

Models

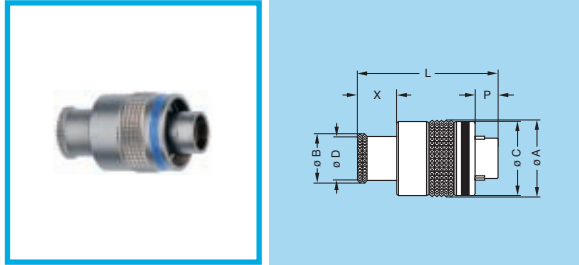

FM• Straight plug, key (N) or keys (P and U) with knurled grip

Reference		Dimensions (mm)							Weight max (g)
Model	Series	A	B	C	D	L	P	X	
FM●	0M	13.1	8.8	12.7	8.0	24.1	4.0	6.7	4.3
FM●	1M	14.6	10.5	14.2	9.7	24.1	4.0	6.7	5.6
FM●	2M	17.6	14.0	17.2	13.0	24.5	4.0	7.1	8.5

Part number example: FMN.1M.305.XLC

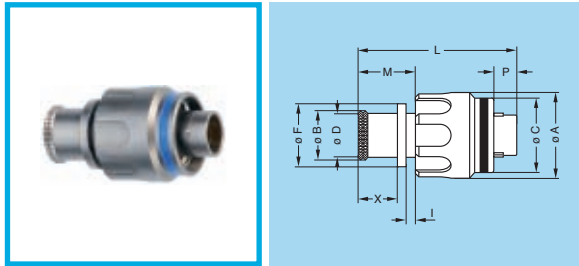

FG• Straight plug, key (N) or keys (P and U) with arctic grip and optional mold stop

Reference		Dimensions (mm)										Weight max (g)
Model	Series	A	B	C	D	F	I	L	M	P	X	
FG●	0M	14.4	8.8	12.7	8.0	10.7	1.5	27.1	9.7	4.0	6.7	4.4
FG●	1M	15.9	10.5	14.2	9.7	12.4	1.5	27.1	9.7	4.0	6.7	5.8
FG●	2M	18.9	14.0	17.2	13.0	15.5	1.5	27.5	10.1	4.0	7.1	7.4

Part number example: FGN.1M.305.XLCT

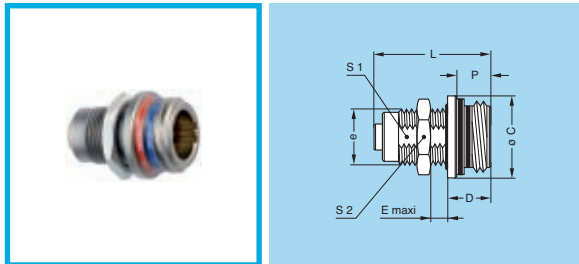

EG• Fixed receptacle, nut fixing, key (N) or keys (P and U)

Reference		Dimensions (mm)								Weight max (g)
Model	Series	C	D	e	E	L	P	S1	S2	
EG●	0M	12.7	6.8	M9x0.6	5.0	18.1	5.3	8.2	11.0	2.7
EG●	1M	14.2	6.8	M11x1.0	4.5	18.1	5.3	9.5	13.0	3.3
EG●	2M	17.2	6.8	M14x1.0	4.5	18.1	5.3	12.5	17.0	4.5

Part number example: EGN.1M.305.XLM

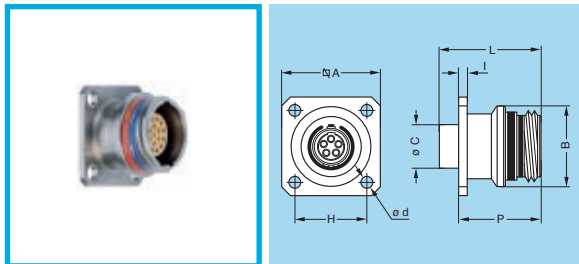

ED• Fixed receptacle with square flange, key (N) or keys (P and U)

Reference		Dimensions (mm)								Weight max (g)
Model	Series	A	B	C	d	H	I	L	P	
ED●	0M	16.0	12.7	4.7	2.7	11.0	1.5	18.5	14.3	3.7
ED●	1M	18.4	14.2	6.0	3.3	12.9	1.5	18.5	14.3	4.8
ED●	2M	20.6	17.2	8.8	3.3	15.1	1.5	18.5	14.3	7.7

Part number example: EDN.1M.305.XLM

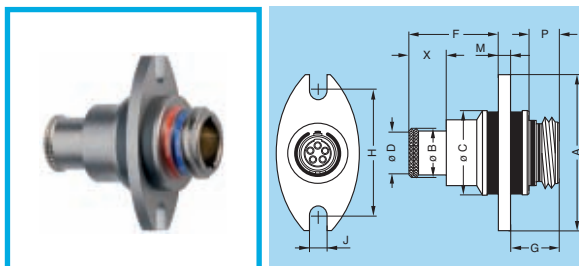

PB• Fixed receptacle with antivibration flange, key (N) or keys (P and U), 2 holes fixing

Reference		Dimensions (mm)										
Model	Series	A	B	C	D	F	G	H	J	M	P	X
PB●	0M	27.0	8.8	14.5	8.0	15.3	8.3	21.4	3.3	2.0	5.3	6.7
PB●	1M	29.0	10.5	16.5	9.7	15.3	8.3	23.4	3.3	2.0	5.3	6.7
PB●	2M	32.0	14.0	19.5	13.0	15.7	8.3	26.4	3.3	2.0	5.3	7.1

Part number example: PBN.1M.305.XLM

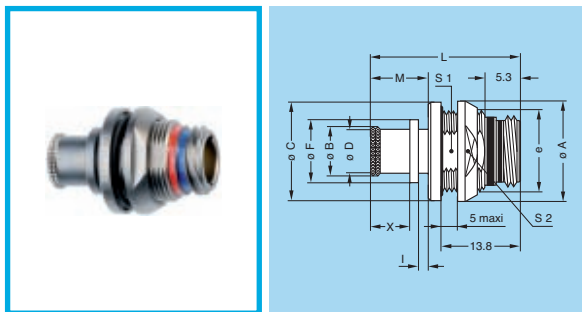

PE• Fixed receptacle, nut fixing, key (N) or keys (P and U) and mold stop (back panel mounting)

Reference		Dimensions (mm)										
Model	Series	A	B	C	D	e	F	L	M	S1	S2	X
PE•	0M	17	8.8	16.8	8.0	M13x0.75	10.7	25.6	9.7	11.5	14	6.7
PE•	1M	18	10.5	17.8	9.7	M14x1.00	12.4	25.6	9.7	12.5	16	6.7
PE•	2M	21	14.0	20.8	13.0	M17x1.00	15.5	26.0	10.1	15.5	18	7.1

Note: the dimension «L» is the same as the FG• models. This model is only available with mold stop.

Part number example: PEN.1M.305.XLMT

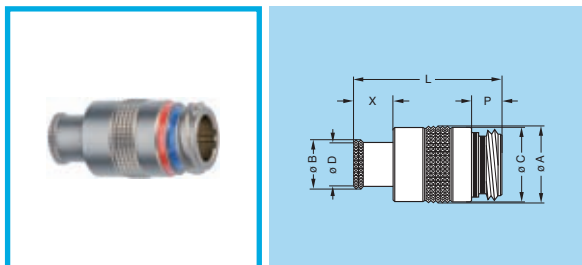

PM• Free receptacle, key (N) or keys (P and U) with knurled grip

Reference		Dimensions (mm)						
Model	Series	A	B	C	D	L	P	X
PM•	0M	13.1	8.8	12.7	8.0	25.6	5.3	6.7
PM•	1M	14.6	10.5	14.2	9.7	25.6	5.3	6.7
PM•	2M	17.6	14.0	17.2	13.0	26.0	5.3	7.1

Part number example: PMN.1M.305.XLM

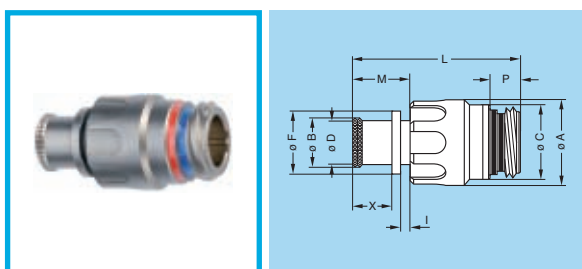

PH• Free receptacle, key (N) or keys (P and U) with arctic grip and optional mold stop

Reference		Dimensions (mm)									
Model	Series	A	B	C	D	F	I	L	M	P	X
PH•	0M	14.4	8.8	12.7	8.0	10.7	1.5	28.6	9.7	5.3	6.7
PH•	1M	15.9	10.5	14.2	9.7	12.4	1.5	28.6	9.7	5.3	6.7
PH•	2M	18.9	14.0	17.2	13.0	15.5	1.5	29.0	10.1	5.3	7.1

Part number example: PHN.1M.305.XLMT

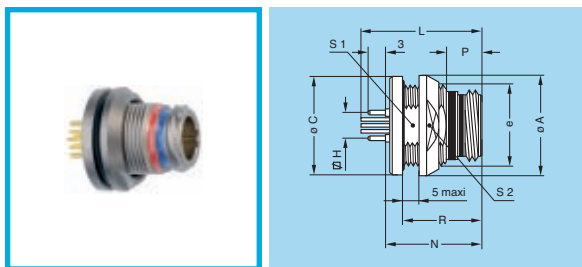

HE• Fixed receptacle, nut fixing, key (N) or keys (P and U) for printed circuit, watertight (back panel mounting)

Reference		Dimensions (mm)									
Model	Series	A	C	e	H	L	N	P	R	S1	S2
HE•	0M	17.0	16.8	M13x0.75	5.08	20.8	16.8	5.3	13.8	11.5	14.0
HE•	1M	18.0	17.8	M14x1.00	7.62	20.8	16.8	5.3	13.8	12.5	16.0
HE•	2M	21.0	20.8	M17x1.00	8.89	20.8	16.8	5.3	13.8	15.5	18.0

Part number example: HEN.1M.305.XLNP

Part Numbering System

FM N . 1M . 307 . X L C T

Model

Keyway (color code):
 N = blue (standard)
 P = yellow
 U = green
 S = red (reverse sex contacts)

Series: 0M to 2M

Variant: T = Mold stop, P = Potted

Contact type:
 C = Male crimp
 M = Female crimp
 N = Female PCB

Insert configuration

Part Number Example

FMN.1M.307.XLCT = Straight plug with key (N), 1M series, multipole type with 7 male crimp contacts, with mold stop.

Alignment Key and Polarized Keying System

M series connector model part numbers are composed of three letters. The THIRD LETTER indicates the key options available to a particular contact type. Straight plugs with N, P or U keys, are fitted with male contacts. Straight plugs with the S key are fitted with female contacts.

Front view of a receptacle 	Model	Nb of keys	Series 0M to 2M		Color code	Contact type Electrical	
			Angles			Plug	Receptacle
			β	γ			
●N	3	165°	30°	blue	male	female	
●P		150°	60°	yellow			
●U		130°	100°	green			
●S		155°	50°	red	female	male	

Insert configuration and electrical characteristics

	Male crimp contacts for plug 	Female crimp contacts for receptacles 	Reference	Number of contacts	ø A (mm)	Contact type		AWG	Test voltage (kV rms) ¹⁾ Contact-contact	Test voltage (kV rms) ¹⁾ Contact-shell	Rated current (A)
						Crimp	Print (straight) ²⁾				
0M			302	2	0.9	●	●	20-22-24	1.45	1.00	10.0
			303	3	0.9	●	●	20-22-24	1.70	1.40	8.0
			304	4	0.7	●	●	22-24-26	1.35	0.90	7.0
			305	5	0.7	●	●	22-24-26	1.25	1.00	6.5
1M			305	5	0.9	●	●	20-22-24	1.30	1.30	9.0
			307	7	0.7	●	●	22-24-26	1.45	1.20	7.0
			308	8	0.7	●	●	22-24-26	1.30	1.10	5.0
2M			308	8	0.9	●	●	20-22-24	1.95	1.10	10.0
			310	10	0.9	●	●	20-22-24	1.80	1.20	8.0
			312	12	0.7	●	●	22-24-26	1.65	1.15	7.0
			319	19	0.7	●	●	22-24-26	1.55	0.95	5.0

Note: 1) Test voltage according to IEC 60512-2 test 4a. 2) For HE• receptacle.

Accessories

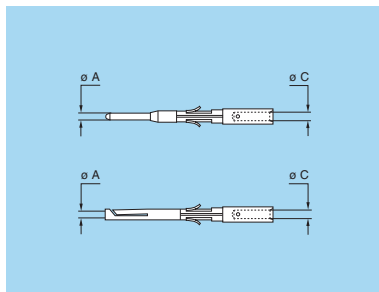

FGN-EGN Crimp contacts

Connector		Contact ø		Conductor				Part number	
Series	Type	ø A	ø C	AWG		Section (mm ²)		male for plug	female for receptacle
				min	max	min	max		
0M	302-303	0.9	1.10	24	20	0.25	0.50	FGN.0M.560.ZZC	EGN.0M.660.ZZM
	304-305	0.7	0.85	26	22	0.14	0.34	FGN.0M.555.ZZC	EGN.0M.655.ZZM
1M	305	0.9	1.10	24	20	0.25	0.50	FGN.0M.560.ZZC	EGN.0M.660.ZZM
	307-308	0.7	0.85	26	22	0.14	0.34	FGN.0M.555.ZZC	EGN.0M.655.ZZM
2M	308-310	0.9	1.10	24	20	0.25	0.50	FGN.0M.560.ZZC	EGN.0M.660.ZZM
	312-319	0.7	0.85	26	22	0.14	0.34	FGN.0M.555.ZZC	EGN.0M.655.ZZM

DCF Extractors for crimp contacts

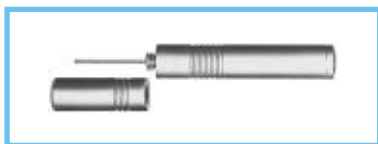

Contact ϕ	Extractors part number
0.9	DCF.93.090.4LT
0.7	DCF.93.070.4LT

Note: this model is used for male and female contacts.

Heatshrink boot

Supplier	Part Number		Note	Cable ϕ (mm)	
	Straight	Elbow 90°		min.	max
Raychem®	202 A 111-25/86	222 A 111-25/86	1)	3.8	11
	202 A 111-25	222 A 111-25	2)	3.8	11
Hellerman®	104-1-G	1108-1-G	2)	3.8	11

Note: 1) modified elastomer resistant to fluids with hot melt sealant.
2) elastomer resistant to fluids. We recommend a thermosetting sealant with this type of boot.

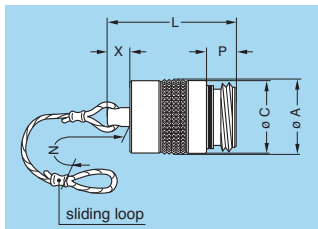

BMF Blanking caps for plugs

Part number	Dimensions (mm)					
	A	C	L	N	P	X
BMF.0M.100.XAV	13.1	12.7	24.6	85.0	5.3	6.0
BMF.1M.100.XAV	14.6	14.2	24.6	85.0	5.3	6.0
BMF.2M.100.XAV	17.6	17.2	24.6	85.0	5.3	6.0

Note: this cap is suitable for use with any alignment key configuration.

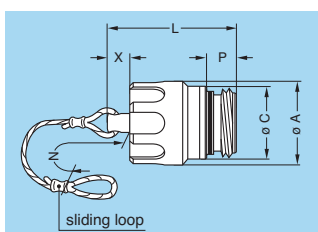

BGF Blanking caps for plugs

Part number	Dimensions (mm)					
	A	C	L	N	P	X
BGF.0M.100.XAV	14.4	12.7	24.6	85.0	5.3	6.0
BGF.1M.100.XAV	15.9	14.2	24.6	85.0	5.3	6.0
BGF.2M.100.XAV	18.9	17.2	24.6	85.0	5.3	6.0

Note: this cap is suitable for use with any alignment key configuration.

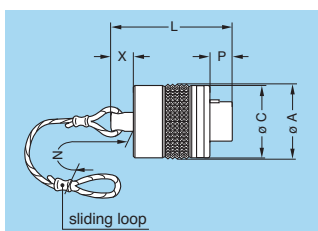

BMF Blanking caps for free receptacles

Part number	Dimensions (mm)					
	A	C	L	N	P	X
BMF.0M.200.XAZ	13.1	12.7	23.4	85.0	4.0	6.0
BMF.1M.200.XAZ	14.6	14.2	23.4	85.0	4.0	6.0
BMF.2M.200.XAZ	17.6	17.2	23.4	85.0	4.0	6.0

Note: this cap is suitable for use with any alignment key configuration.

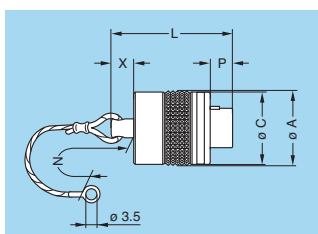

BME Blanking caps for fixed receptacles

Part number	Dimensions (mm)					
	A	C	L	N	P	X
BME.0M.200.XAZ	13.1	12.7	23.4	85.0	4.0	6.0
BME.1M.200.XAZ	14.6	14.2	23.4	85.0	4.0	6.0
BME.2M.200.XAZ	17.6	17.2	23.4	85.0	4.0	6.0

Note: this cap is suitable for use with any alignment key configuration.

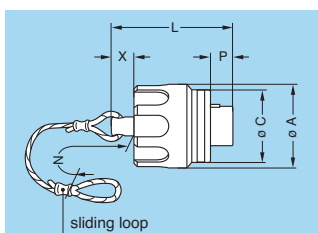

BGF Blanking caps for free receptacles

Part number	Dimensions (mm)					
	A	C	L	N	P	X
BGF.0M.200.XAZ	14.4	12.7	23.4	85.0	4.0	6.0
BGF.1M.200.XAZ	15.9	14.2	23.4	85.0	4.0	6.0
BGF.2M.200.XAZ	18.9	17.2	23.4	85.0	4.0	6.0

Note: this cap is suitable for use with any alignment key configuration.

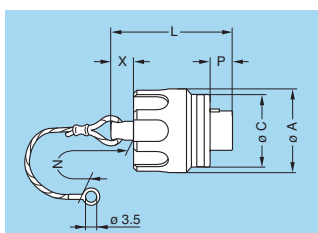

BGE Blanking caps for fixed receptacles

Part number	Dimensions (mm)					
	A	C	L	N	P	X
BGE.0M.200.XAZ	14.4	12.7	23.4	85.0	4.0	6.0
BGE.1M.200.XAZ	15.9	14.2	23.4	85.0	4.0	6.0
BGE.2M.200.XAZ	18.9	17.2	23.4	85.0	4.0	6.0

Note: this cap is suitable for use with any alignment key configuration.

Tooling

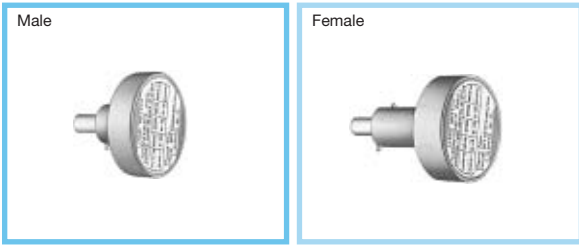

Note: These positioners are suitable for use with both manual and pneumatic crimping tools according to the MIL-C-22520/7-01 standard.

DCE Positioners for crimp contacts

Connector		Contact ϕ		Positioners part number	
Series	Type	ϕA	ϕC	For male contacts	For female contacts
0M	302-303	0.9	1.10	DCE.91.090.5MVC	DCE.91.090.3MVM
	304-305	0.7	0.85	DCE.91.070.5MVC	DCE.91.070.3MVM
1M	305	0.9	1.10	DCE.91.090.5MVC	DCE.91.090.3MVM
	307-308	0.7	0.85	DCE.91.070.5MVC	DCE.91.070.3MVM
2M	308-310	0.9	1.10	DCE.91.090.5MVC	DCE.91.090.3MVM
	312-319	0.7	0.85	DCE.91.070.5MVC	DCE.91.070.3MVM

Panel cut-outs

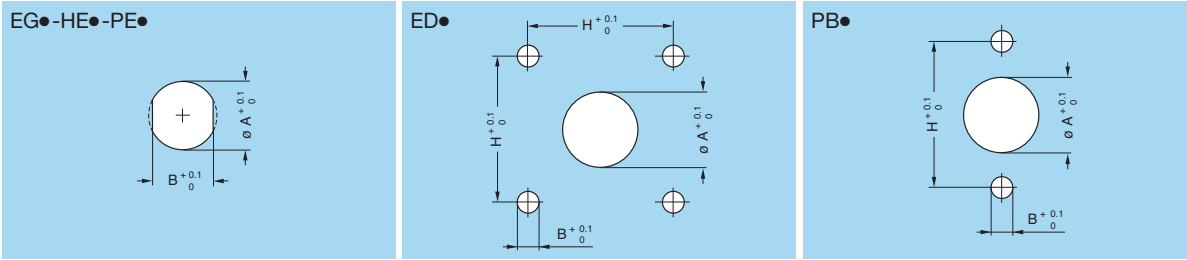

Cut-outs

Series	Models											
	EG●		HE●		PE●		ED●			PB●		
	ϕA	B	ϕA	B	ϕA	B	ϕA	B	H	ϕA	B	H
0M	9.1	8.3	13.1	11.6	13.1	11.6	5.1	M2.5	11.0	14.8	M3.0	21.4
1M	11.1	9.6	14.1	12.6	14.1	12.6	6.1	M3.0	12.9	16.8	M3.0	23.4
2M	14.1	12.6	17.1	15.6	17.1	15.6	9.1	M3.0	15.1	19.8	M3.0	26.4

Tightening/Untightening torque (plug-receptacle)

Series	Torque (N.cm)	
	Tightening	Untightening
0M	2.8-3.9	4.6-5.9
1M	3.0-4.0	4.5-6.0
2M	7.0-12.0	9.0-14.0

Mounting nut torque (on panel)

Series	Torque (N.m)
0M	1.0
1M	1.5
2M	2.0

PCB drilling pattern (HE●)

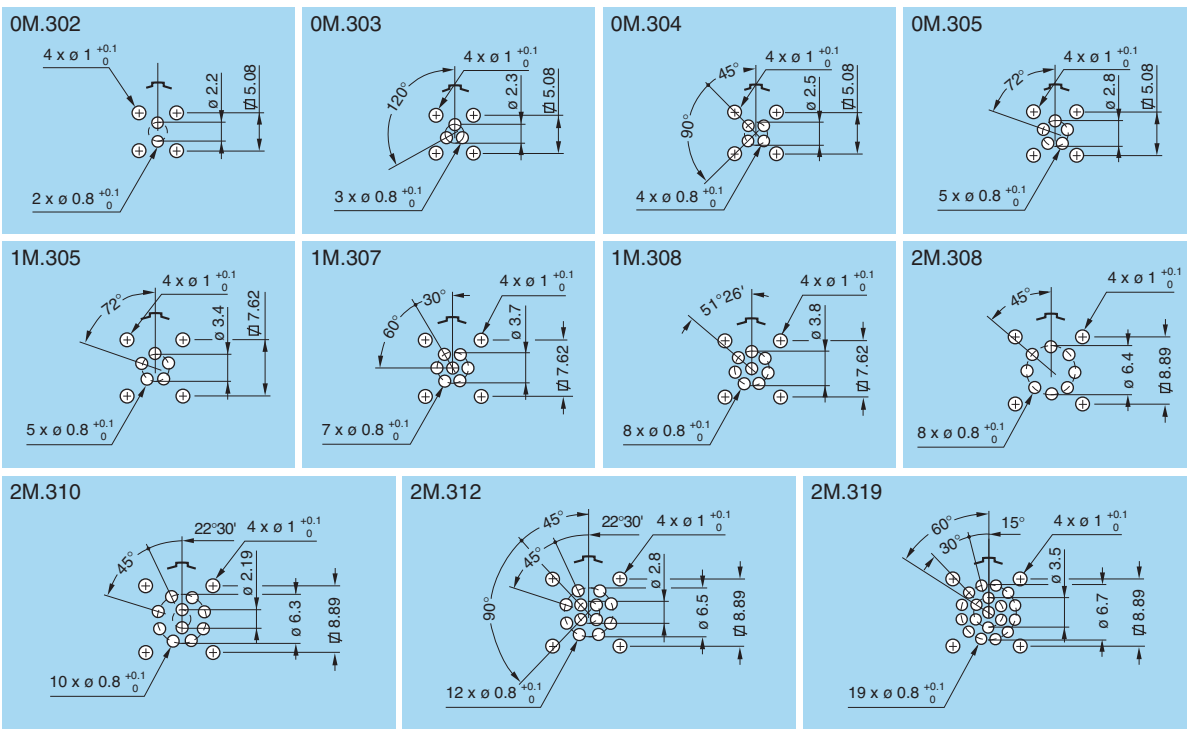

Assembly instructions for plugs and receptacles

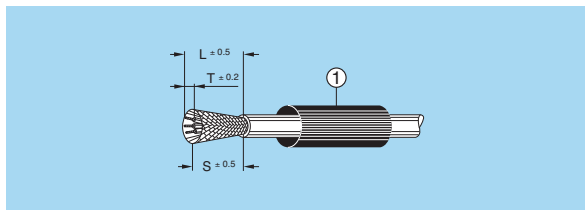
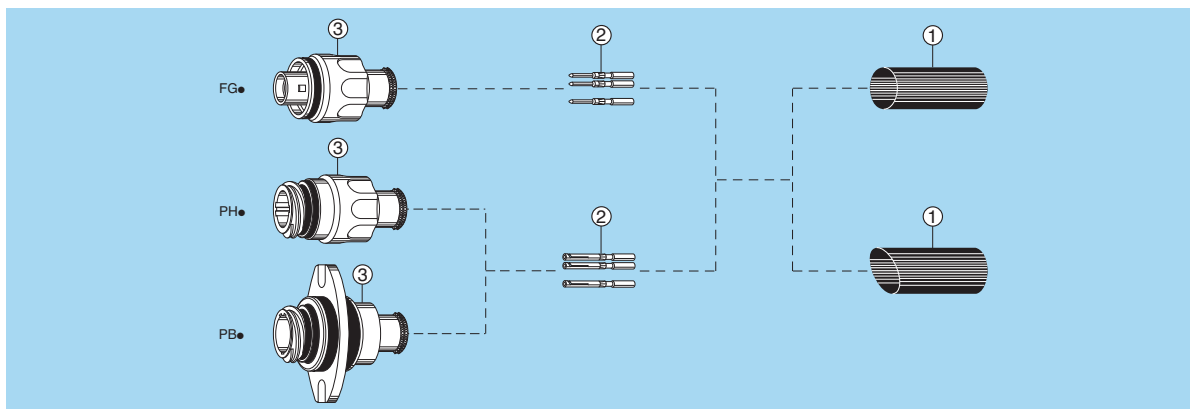

1. Cable preparation

First place the heatshrink boot ① over the cable. Strip the cable according to dimensions of the table, then widen the shield.

Series	L	S	T
0M	13	7.0	4
1M	13	7.0	4
2M	13	7.5	4

Note: dimensions are in mm.

2. Cable termination

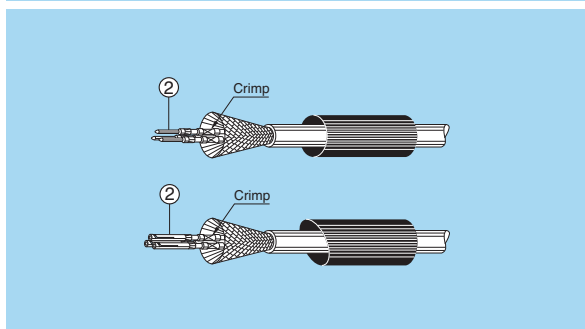

2.1 With shielded cables, widen and fold the shield to the back. Insert the appropriate positioner onto the crimping tool and set the selector to the number corresponding to the AWG of the conductor used as indicated on the positioner label. Fit the conductor into the contact ②; make sure it is visible through the contact's inspection hole.

Slide the conductor-contact assembly into the open crimping tool; make sure that the contact is pushed fully into the positioner then crimp.

Remove from crimping tool and check that conductor is secure in contact and shows in inspection hole.

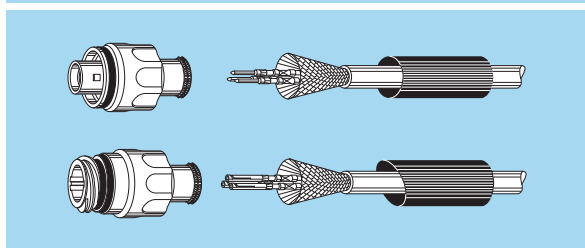

2.2 Arrange the conductor-contact assemblies according to the markings, into the rear cable seal. Push them deeply into the insulator, using tweezers if necessary; check that all the contacts are correctly located in the insulator: 1) by verifying the alignment of the contacts at the front of the insulator and 2) by gently pulling on each conductor. Verification should also be made using the appropriate retention testing tool.

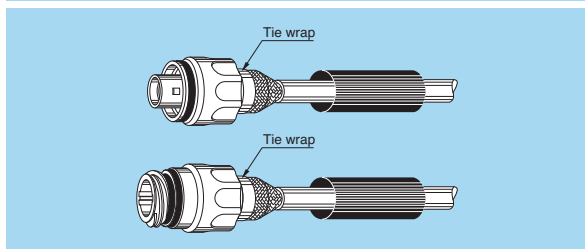

2.3 Bring the shield around the rear of connector. Secure it with a band-it tie-wrap (not furnished) to fix the shield in place. Cut off the possible shield surplus.

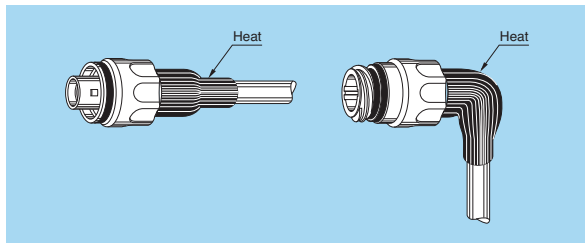

2.4 Put the heatshrink boot in place and heat gently until it retracts.

Assembly instructions for plugs and receptacles (with optional mold stop)

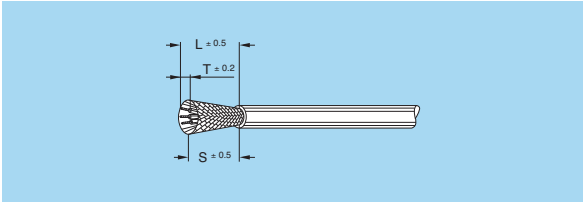
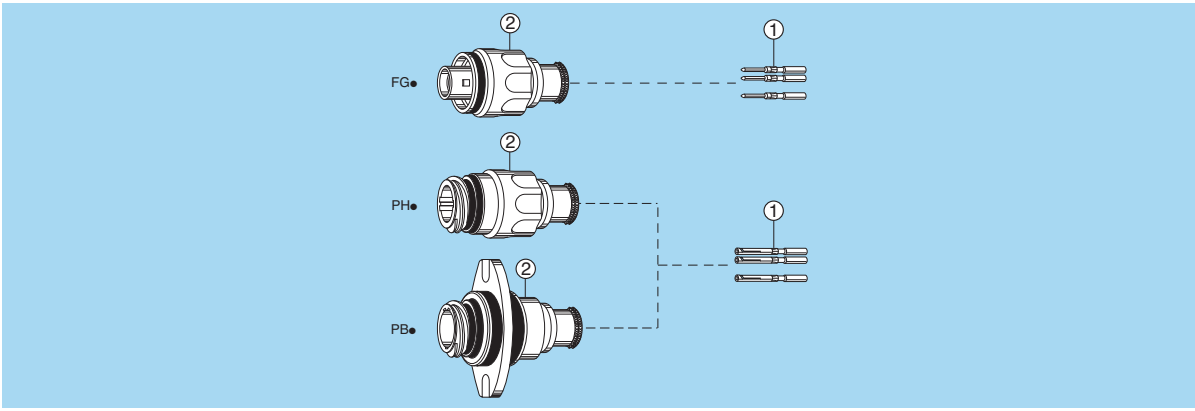

1. Cable preparation

Strip the cable according to dimensions of the table, then widen the shield.

Series	L	S	T
0M	16	7.0	4
1M	16	7.0	4
2M	16	7.5	4

Note: dimensions are in mm.

2. Cable termination

2.1 With shielded cables, widen and fold the shield to the back. Insert the appropriate positioner onto the crimping tool and set the selector to the number corresponding to the AWG of the conductor used as indicated on the positioner label. Fit the conductor into the contact ①; make sure it is visible through the contact's inspection hole. Slide the conductor-contact assembly into the open crimping tool; make sure that the contact is pushed fully into the positioner and crimp. Remove from crimping tool and check that conductor is secure in contact and shows in inspection hole.

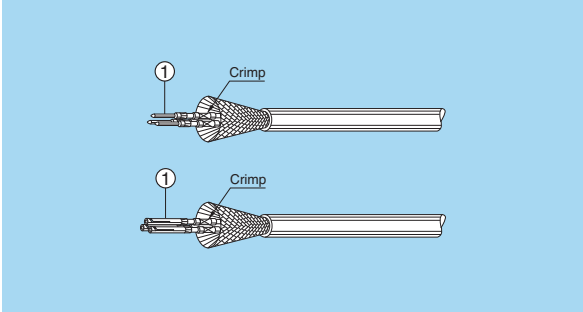

2.2 Arrange the conductor-contact assemblies according to the markings, into the rear cable seal. Push them deeply into the insulator, using tweezers if necessary; check that all the contacts are correctly located in the insulator: 1) by verifying the alignment of the contacts at the front of the insulator and 2) by gently pulling on each conductor. Verification should also be made using the appropriate retention testing tool.

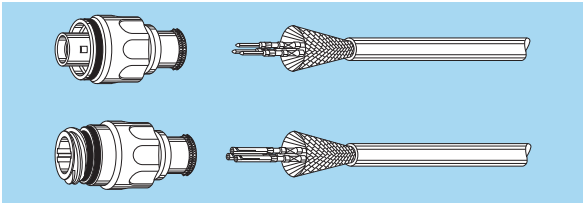

2.3 Bring the shield around the rear of connector until the mold stop. Secure it with a band-it tie-wrap (not furnished) to fix the shield in place. Cut off the possible shield surplus.

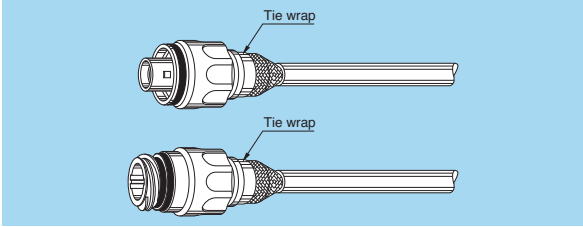

2.4 Custom overmold cable assembly.

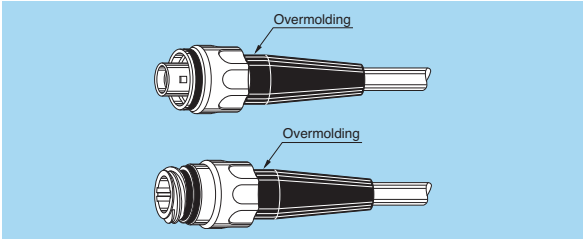

Data subject to change, printed in USA, May 2009

LEMO USA, Inc.
 800-444-5366
 email: info@lemousa.com

www.lemo.com

© CAT.MM.LUSP0509