

Strut profiles with 10 mm slot

The Rexroth modular profile system, with 10 mm slots in the modular dimensions 40 mm, 45 mm, 50 mm, and 60 mm, caters for all the profile dimensions commonly found in the world market.

Thanks to their computer-optimized design, the strut profiles ...L with 10 mm slot (modular dimensions 40 mm,

45 mm, and 50 mm, e.g. 50x50L) combine high strength values with economical use of materials. This gives you a cost-effective and stable solution for the construction of tables, protection devices or frames, for instance.

Slot, modular dimensions, central bore

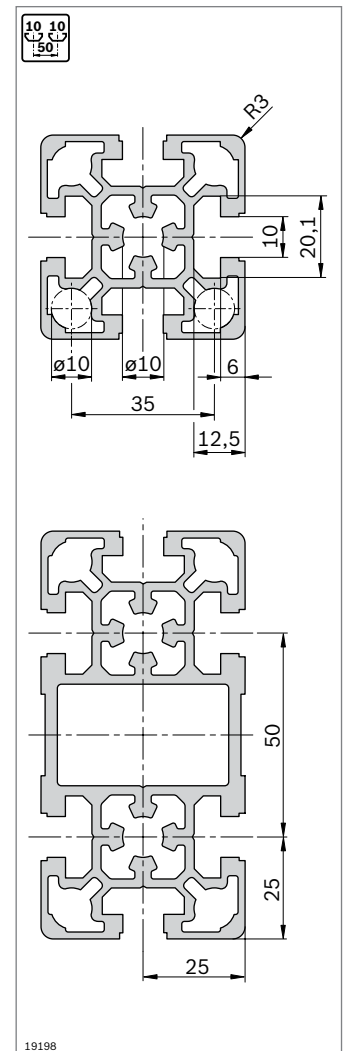
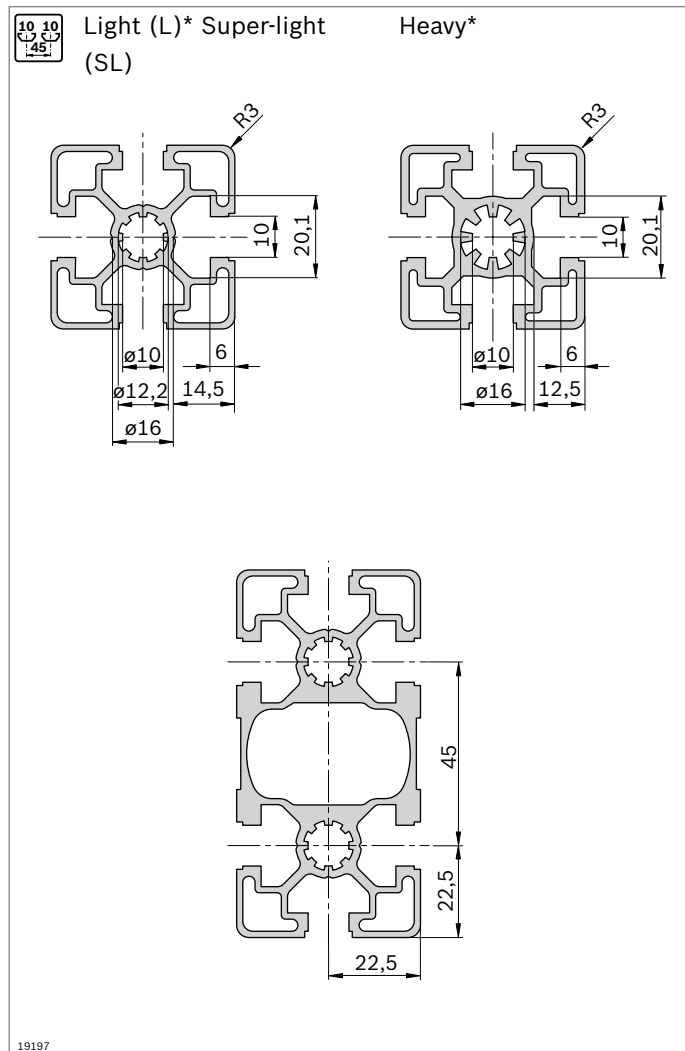
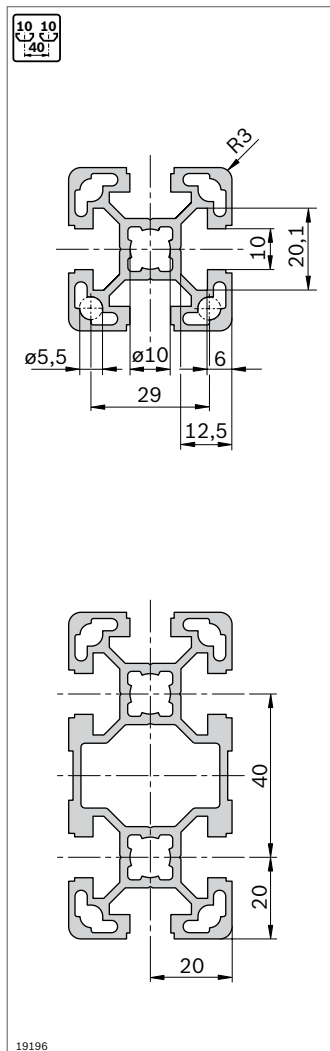

*) The following L-profiles have a "heavy" slot geometry:
45x90x90L; 45x90x90L 4N; 90x90L; 90x90L 4N; 90x90L 4NVS; 90x180L

Minimum profile lengths (mm) for Quick & Easy standard profile finishes on one or both sides

	-	M12	M16	D9.8	D17/DB17	F1
-	50	60	120	50	60	60
M12	60	110	180	90	90	110
M16	120	180	240	150	170	170
D9.8	50	90	150	80	70	90
D17/DB17	60	90	170	70	80	90
F1	60	110	170	90	90	80

For applications with high loads we recommend profiles with the especially stable 10 mm slot e.g. for heavy work tables, fixtures, machine frames, transport shuttles, protective enclosures, and handling systems.

Due to its very sturdy design, this slot makes extremely strong connections possible.

Profile finishing

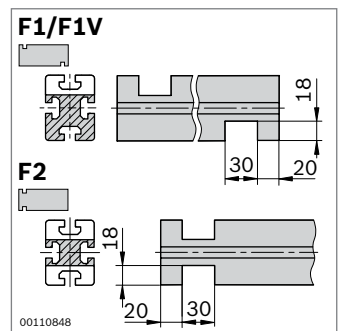
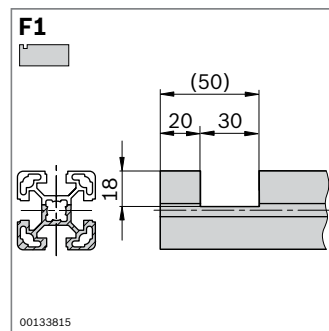
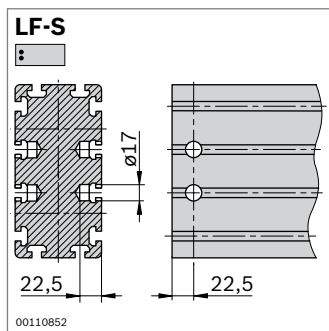
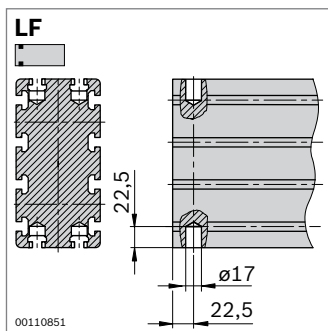
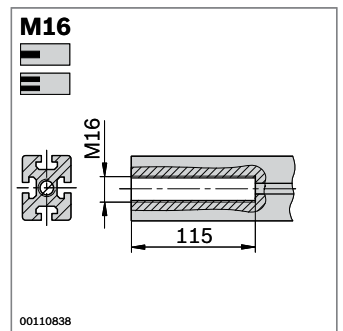
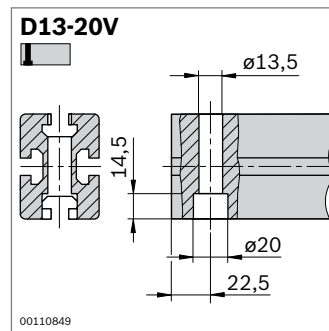
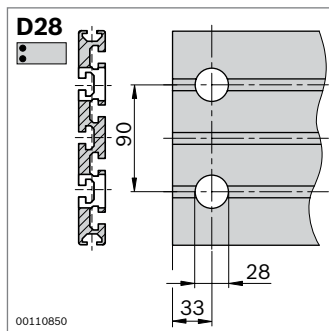
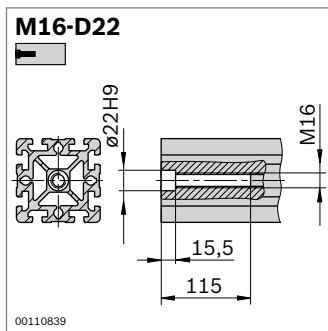
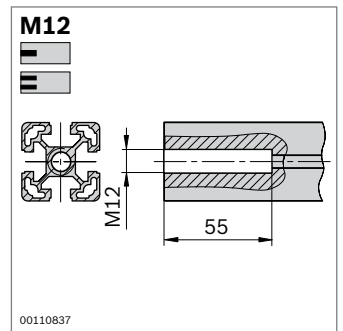
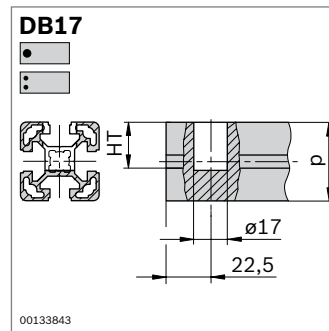
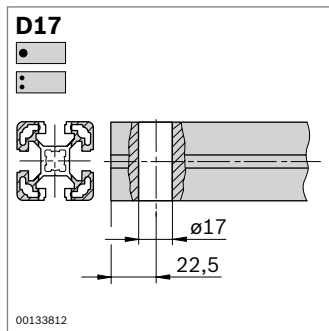
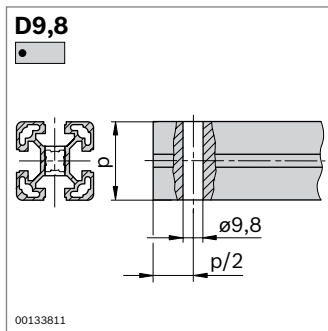

40x40L R

A = 5,0 cm²
 I_x = 7,2 cm⁴
 I_y = 7,2 cm⁴
 W_x = 3,6 cm³
 W_y = 3,6 cm³
 m = 1,3 kg/m

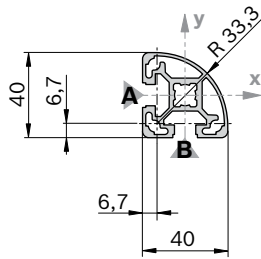

19208

Cover cap	Color	ESD	No.
40x40 R (1x)	Signal grey		20 3 842 548 784
40x40 R (1x)	Black		20 3 842 548 785

Material: PP

40x40 HR

A = 5,5 cm²
 I_x = 8,1 cm⁴
 I_y = 7,6 cm⁴
 W_x = 4,0 cm³
 W_y = 3,6 cm³
 m = 1,5 kg/m

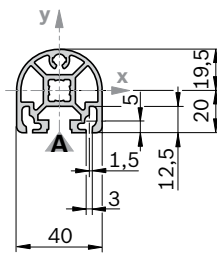

19209

Cover cap	Color	ESD	No.
40x40 HR (1x)	Signal grey		20 3 842 548 786
40x40 HR (1x)	Black		20 3 842 548 787

Material: PP

Cover cap with hole ¹⁾	Color	ESD	No.
40x40 HR (1x)	Signal grey		20 3 842 548 786
40x40 HR (1x)	Black		20 3 842 548 787

Material: PP

¹⁾The cover cap is also suitable for use with a hole, which can be broken out

40x40L R	L (mm)	No.
1 unit	50 ... 6000	3 842 993 184 / L
20 units	6070	3 842 529 359

Quick & Easy (p. 2-8, see fold-out section)

40x40L R	3 842 993 725 / ...
Length L (mm)	50 ... 6000
Standard profile finishes (note minimum length, p. 2-25)	M12 / DB17 (A,B) ¹⁾
Customized profile finishes	—

¹⁾ For the specified slots

40x40 HR	L (mm)	No.
1 unit	50 ... 6000	3 842 993 256 / L
1 unit M12	110 ... 6000	3 842 993 257 / L
20 units	6070	3 842 529 381

Quick & Easy (p. 2-8, see fold-out section)

40x40 HR	3 842 993 723 / ...
Length L (mm)	50 ... 6000
Standard profile finishes (note minimum length, p. 2-25)	M12 / DB17
Customized profile finishes (L _{max} = 5400 mm)	DI / DIS / MT / MTS / MI / MIS / DG ¹⁾

¹⁾ DG_{max} = 45°; L_{min1} / L_{min2} = 370 / 440 mm