

FüÙe und Räder · Feet and wheels · Pieds et roues

# Platte Plate Plaque



00126170

■  
Platte zur Befestigung von GelenkfüÙen in Profilen ohne zentralen Kernzug. Auch als End- oder T-Verbinder einsetzbar.

Material:  
– Aluminiumdruckguss

■  
Plate for fastening leveling feet in profiles without core. May also be used as an end or T-connector.

Material:  
– die-cast aluminum

■  
Plaque de fixation pour pieds articulés dans les profilés sans alésage central. Utilisable également comme liaison terminale ou comme jonction en T.

Matériau :  
– aluminium coulé sous pression

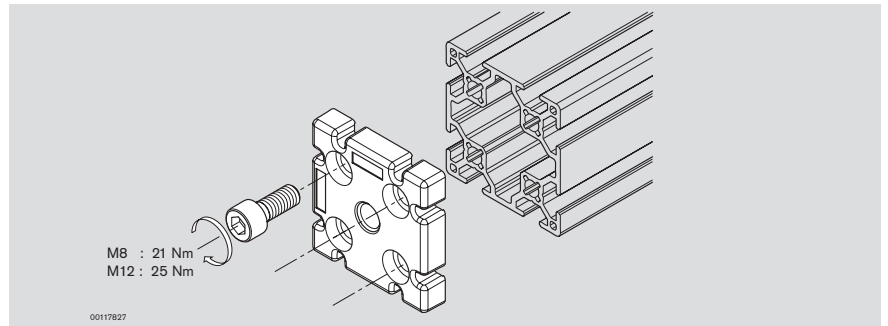

00117827

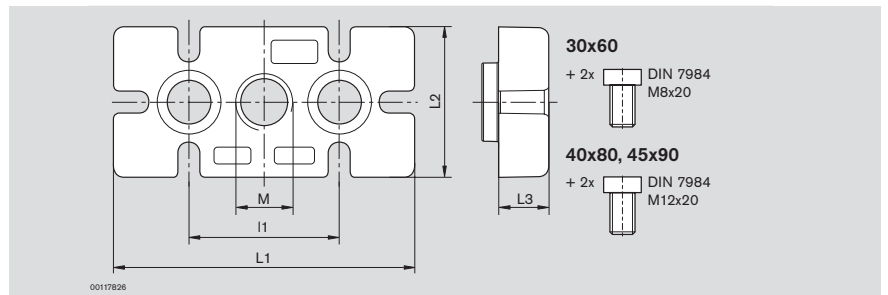

00117826

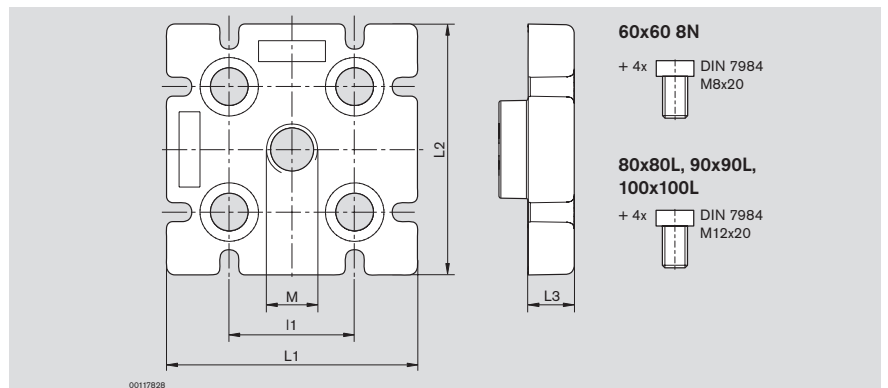

00117826

Platte  
Plate  
Plaque

			M	L1	L2	l1	L3	F [N]	Nr./No./N°
<b>30x60</b>	M8		12	60	30	30	11	8000	<b>3 842 536 560</b>
<b>60x60 8N</b>	M8		12	60	60	30	11	10000	<b>3 842 536 566</b>
<b>40x80</b>	M12		12	80	40	40	15	10000	<b>3 842 536 562</b>
<b>45x90</b>	M12		16	90	45	45	15	20000	<b>3 842 536 564</b>
<b>80x80L</b>	M12		12	80	80	40	15	10000	<b>3 842 529 416</b>
<b>90x90L</b>	M12		16	90	90	45	15	20000	<b>3 842 511 352</b>
<b>100x100L</b>	M12		16	100	100	50	15	20000	<b>3 842 529 417</b>