



ROSE+BOPLA
ENCLOSURES

A PHOENIX MECANO COMPANY

BG

Handheld Enclosures

Product Drawings

Last Updated 6/20/2008

Rose+Bopla Enclosures
7330 Executive Way
Frederick, MD 21704
301-696-9800
www.rose-bopla.com
rbinfo@pm-usa.com

Dimensional Drawings

For Secondary Services, Product Support, or To Order, Call 1-301-696-9800



TECHNICAL DATA:

- Color: black-gray similar to RAL 7021
- Material: Polyamide
- Ingress protection: IP 65 to EN 60529
- Surface resistance: 10^{12} Ohm to DIN 53482
- Impact resistance: >7 Nm to DIN 50014
- Flammability: UL 94 V2
- Gasket: removable Neoprene gasket
- Temperature resistance: -40°F up to +140°F
- Membrane keypad ready



The BG mobile hand-held enclosure series is designed to meet today's demanding automation engineering requirements where mobile systems are a necessity. These robust ergonomically

BG Handheld Series

designed enclosures are made of durable polyamide and feature a tongue and groove sealing system with an integrated gasket that provides an ingress protection up to the IP 65. The BG 180 and 220 hand-held enclosures are ideal for use in areas such as machine operation and control, set-up tasks and status analysis, and measuring applications in harsh environments.

BG hand-held enclosures are available in a closed design, or open for display mounting, with the exception of the 380 model, which is only offered in the closed design. The construction of the BG 180 and 220 offers a lot of practical advantages—the angled head section makes a display very easy to read; the upper part is recessed to accommodate membrane keypads; and large functional areas are provided for electromechanical switches, buttons, or membrane keypads. The larger BG 380 model, with dimensions of 380 x 117 x 68 mm, opens up a wide range of application options like machine control devices, display enclosures, or measurement and control instruments. The symmetrical design of the 380 is suitable for use as a hand-held enclosure, a desktop enclosure, a wall-mount enclosure, or for use as a mobile device attached with a waist belt. For our Ex Version see page 6-15.

BG Handheld Enclosures					
Part Number	Type	Length (Inches/mm)	Width Top (Inches/mm)	Width Bot. (Inches/mm)	Drawing
27020200	BG 180 O	7.36 / 187	4.17 / 106	2.95 / 75	17-115
27020201	BG 180 G	7.36 / 187	4.17 / 106	2.95 / 75	17-115
27020400	BG 220 O	8.66 / 220	4.57 / 116	3.35 / 85	17-115
27020401	BG 220 G	8.66 / 220	4.57 / 116	3.35 / 85	17-115
27020501	BG 380 G	14.96 / 380	4.61 / 117	2.68 / 68	17-116

O=open G=closed

Note: Dimensions are external. Metric is the primary dimension. Inch conversions are for the user's convenience and are for reference only.

Accessories shown on drawing page.

◀ Clockwise from top left: BG 380 with large 1/4 VGA display. BG 180 or 220 showing variable display mounting kit. BG 380 with membrane keypads and large display. BG 180 or BG 220 with display, membrane keypad, and electromechanical components.



BG 180 / BG 180 Ex

External Dimensions: L187 x W106 x H50mm

Page 4-6, 7, 6-15

Standard Features
<ul style="list-style-type: none"> * 27020200 Open version Top part with gasket, bottom part, enclosure and board mounting screws, gasket rings, tongue-and-groove system with integrated gasket. Includes display screen and punched gasket (max. display board dimensions approx. 74 x 56.4mm or 80 x 54mm). * 27020201 Closed Version Top part with gasket, bottom part, enclosure and board mounting screws, gasket rings, tongue-and-groove system with integrated gasket. * 28020200 Ex Open version Top part with gasket, bottom part, enclosure and board mounting screws, gasket rings, tongue-and-groove system with integrated gasket. Includes display screen and punched gasket (max. display board dimensions approx. 74 x 56.4mm or 80 x 54mm). * 28020201 Ex Closed Version Top part with gasket, bottom part, enclosure and board mounting screws, gasket rings, tongue-and-groove system with integrated gasket.
Accessories
<ul style="list-style-type: none"> * 27010680 Display mounting set for variable display mounting. * 27010688 Spare display screen set (display screen, punched gasket). * 27020080 Hook set consisting of mounted hook & mounting screws, without magnet. * 27020081 Hook set consisting of mounted hook and mounting screws, with magnet. * 27020082 Spare screw set (12 board mounting screws, 6 enclosure screws, 6 gasket rings, 4 mounting screws). * 27020083 Hand strap

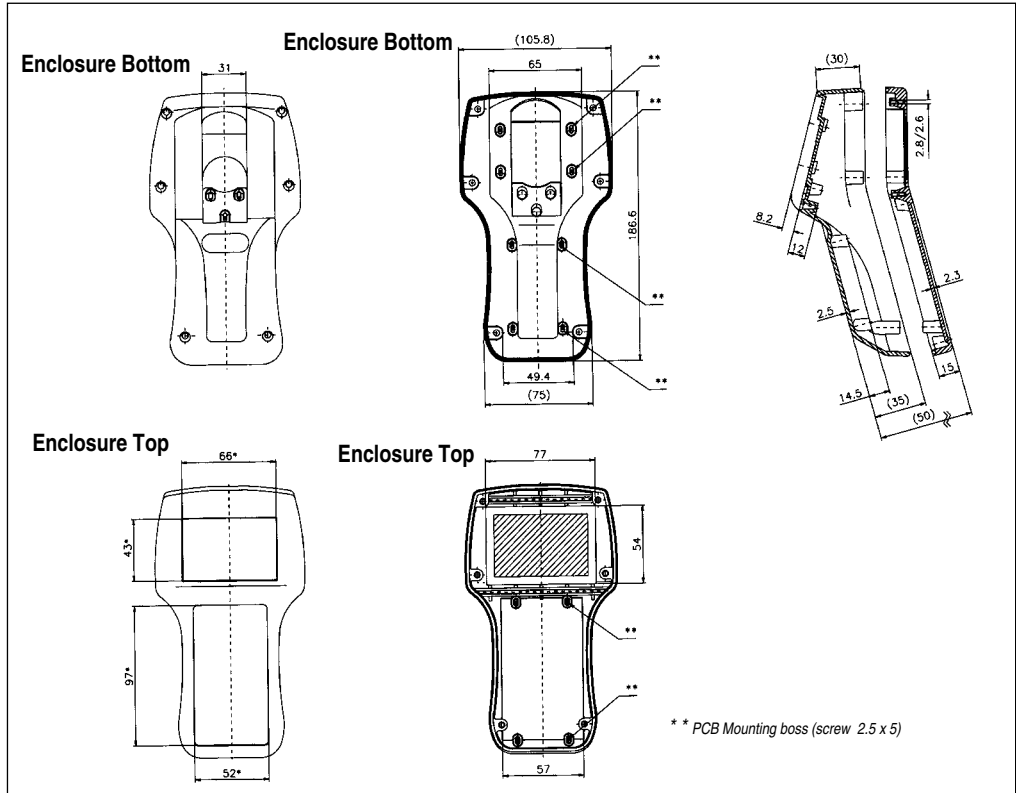

BG 220 / BG 220 Ex

External Dimensions: L220 x W116 x H51mm

Page 4-6, 7, 6-15

Standard Features
<ul style="list-style-type: none"> * 27020400 Open version Top part with gasket, bottom part, enclosure and board mounting screws, gasket rings, tongue-and-groove system with integrated gasket. Includes display screen and punched gasket (max. display board dimensions approx. 84 x 71.5mm or 86 x 70.5mm). * 27020401 Closed Version Top part with gasket, bottom part, enclosure and board mounting screws, gasket rings, tongue-and-groove system with integrated gasket. * 28020400 Ex Open version Top part with gasket, bottom part, enclosure and board mounting screws, gasket rings, tongue-and-groove system with integrated gasket. Includes display screen and punched gasket (max. display board dimensions approx. 84 x 71.5mm or 86 x 70.5mm). * 28020401 Ex Closed Version Top part with gasket, bottom part, enclosure and board mounting screws, gasket rings, tongue-and-groove system with integrated gasket.
Accessories
<ul style="list-style-type: none"> * 27020080 Hook set consisting of mounted hook and mounting screws, without magnet. * 27020081 Hook set consisting of mounted hook and mounting screws, with magnet. * 27020482 Display mounting set for variable display mountings. * 27020483 Spare display screen set (display screen, punched gasket). * 27020083 Hand strap. * 27020082 Spare screw set (12 board mounting screws, 6 enclosure screws, 6 gasket rings, 4 mounting screws).

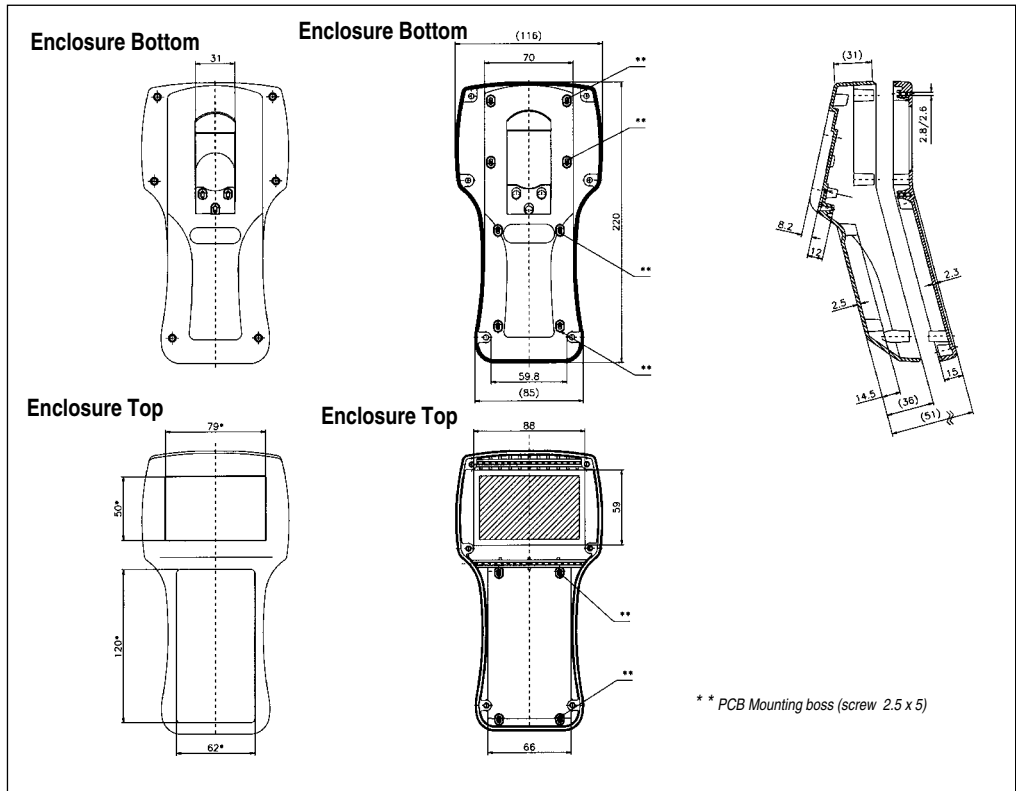

Dimensional Drawings

Standard Features

- **27020501 BG 380** Includes: Top part with seal, bottom part with hang-up / set, enclosure and board mounting screws, sealing rings, tongue and groove system with intergrated seal.
- **28020501 BG 380 Ex Version** Includes: Top part with seal, bottom part with hang-up / set, enclosure and board mounting screws, sealing rings, tongue and groove system with intergrated seal.

Accessories

- **27020582** Wall mounting set.
- **27020583** Spare screw set (14 board mounting screws, 6 enclosure screws, 6 gasket rings, 4 hang-up/set-up screws).
- **27020580** Body belt.
- **27020581** Hand strap.
- **08110111** Power Cable Grip, PG 11.
- **08110113** Power Cable Grip, PG 13.5.
- **08100116** Cable Grip with strain protection M16.
- **08100120** Cable Grip with strain protection M20.

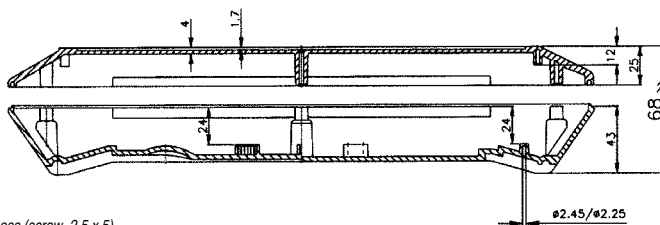
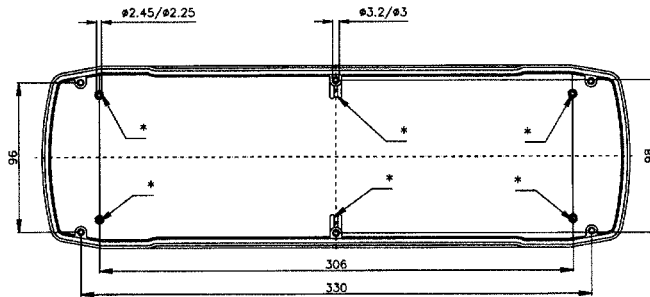
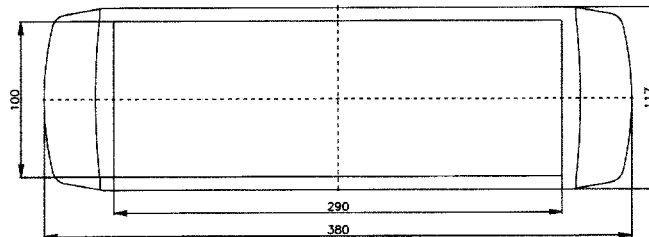
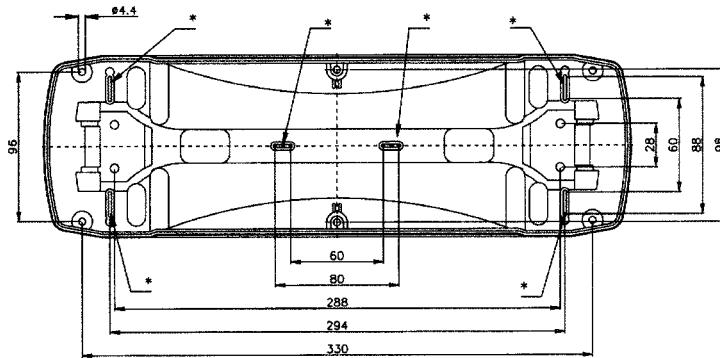
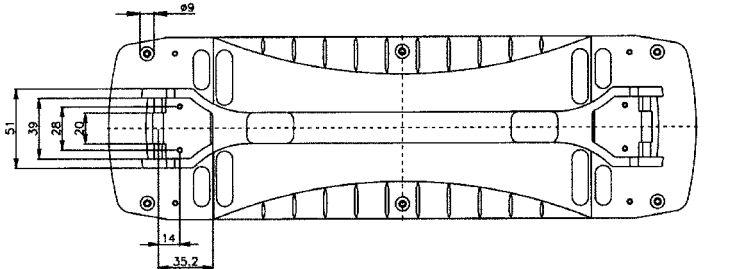

** PCB Mounting boss (screw 2.5 x 5)