

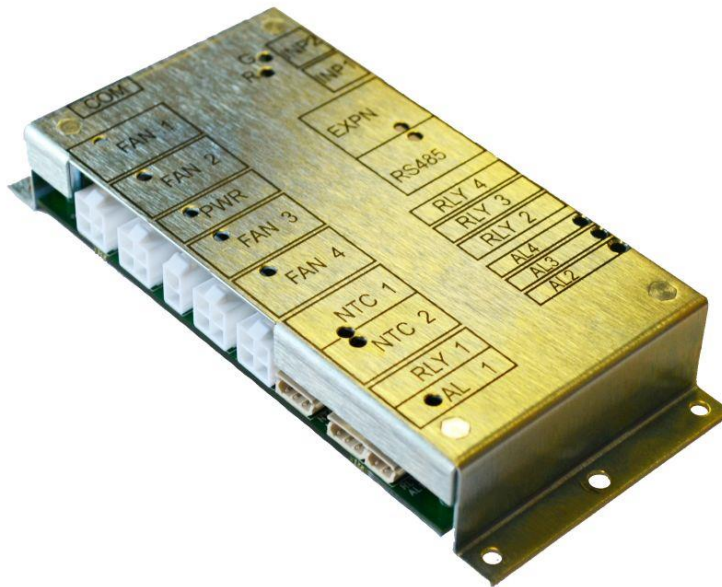

**Operation and Maintenance Instructions
for
Thermal Management System (TMS)
(Excluding Configuration Interface)
Part Number: TMSB00000-01**

Fan speed controller, 1 to 4 fans,
11-57V supply, highly configurable, alarm monitoring, enclosure.



**Copyright (c) ebm-papst UK Ltd 2015
This document, including any concepts or techniques used,
is the intellectual property of ebm-papst UK Ltd.**

**ebm-papst UK Ltd
Chelmsford Business Park
Chelmsford
Essex
CM2 5EZ**

**Tel: +44 (0) 1245 468555
Fax: +44 (0) 1245 466336**

www.ebmpapst.co.uk

The most recent version of this document is available for download at:
www.ebmpapst.co.uk/instructions



INDEX

- 1 SUMMARY 4**
- 2 MAIN FEATURES 4**
- 3 DC SUPPLY 5**
 - 3.1 USE WITH -48VDC SUPPLY 5
- 4 FAN INTERFACE 5**
- 5 FAN CONTROL 5**
 - 5.1 TEMPERATURE PROFILE 5
 - 5.2 MULTI. POINT PROFILE MENU OPTION 6
 - 5.3 CONFIGURATION 6
 - 5.4 DUMMY FAN LINKS 6
 - 5.5 DAILY FAN RUN 6
 - 5.6 PWM FREQUENCY 7
- 6 ALARMS 7**
 - 6.1 ALARM INTERFACE 7
 - 6.2 ALARM CRITERION 7
 - 6.3 ALARM ACTIONS 7
 - 6.4 FAN FAIL CRITERION 7
 - 6.5 ALARM LED INDICATIONS 7
- 7 ENVIRONMENT 8**
- 8 EMC COMPLIANCE 8**
- 9 SAFETY 8**
- 10 ROHS 8**
- 11 FUSES 8**
- 12 SWITCH INPUTS 8**
- 13 MECHANICS, ENCLOSURE 8**
 - 13.1 DIN RAIL MOUNTING 9
- 14 IDENTIFICATION OF CONNECTORS, LED'S AND PIN NUMBERING 10**
 - 14.1 CONNECTORS, FRONT EDGE OF PCB, PIN NUMBERING 10
 - 14.2 CONNECTORS, REAR EDGE OF PCB, PIN NUMBERING 10
- 15 MATING CONNECTOR TYPES AND PIN CONFIGURATION 11**
 - FRONT EDGE CONNECTIONS 11
 - POWER INPUT 11
 - FANS 11
 - CRIMPS FOR POWER AND FAN CONNECTORS 11
 - THERMISTORS AND 0-10V INPUTS 11
 - RELAY OUTPUTS, RELAY 1 11
 - REAR EDGE CONNECTIONS 12
 - RELAY OUTPUTS, RELAYS 2-4 12
 - RELAY EXPANSION 12
 - SWITCH INPUTS 1-2 12
 - CRIMPS FOR NTC THERMISTORS, RELAY OUTPUTS, SWITCH INPUTS, RELAY DAUGHTERBOARD AND CONFIGURATION INTERFACE 12
 - RS485 INTERFACE (CUSTOMER SPECIFIC SOFTWARE USE ONLY.) 12
 - END CONNECTIONS 12
 - COMS - CONFIGURATION AND MONITORING INTERFACE 12
 - TEST CONNECTOR 12
- 16 THERMISTORS 13**



16.1 THERMISTOR CABLE ASSEMBLY ACCESSORY..... 13

17 RELAY DAUGHTERBOARD ACCESSORY (PRELIMINARY)..... 13

18 DUMMY FAN LINK ACCESSORY..... 13

19 CONFIGURATION CABLE ASSEMBLY ACCESSORY..... 14

20 DEVELOPMENT CABLE SET ACCESSORY..... 14

21 FAN COMPATIBILITY AND EXAMPLE RECOMMENDED SETTINGS 14

21.1 RECOMMENDED FAN SETTINGS 14

22 TMS / HMS CONTROLLER, SUMMARY OF DIFFERENCES..... 16

23 CE CERTIFICATE, COPY OF FRONT SHEET 17

DOCUMENT HISTORY

6	9 April 2015	Removed reference to configuration interface	LA
5	9 Oct 2012	Add Fan Configuration Examples	JE
4	20 July 2012	Add Relay type Fans, Daily Fan Run & PWM Freq.	JE
3	2 Sept 2011	Correct Power Connector pin-out	JE
2	10 June 2011	Update 0-10V input, document number changed	JE
1	13 May 2011	Update instructions, Relay 2-4 connector combined	JE
Issue	Date	Comments	Name

For information on Configuration Interface refer to documents:
 Text based user interface; 210-OMI13963
 Graphical user interface; 210-OMI13962
 These documents may be downloaded from www.ebmpapst.co.uk/instructions

The master of this document is stored at ebm-papst Chelmsford, Essex, UK:
 T:\Design Projects\6685 - Thermal Management System - epUK\Specifications\OMI



1 Summary

This Thermal Management System (TMS) controller sets the speed of up to four fans, based on temperature. It is designed for use with four wire type fans (Power, 0V, Speed control, Tachometer) on 12V, 24V or 48V systems. It can also be used with mains powered EC fans if a separate power supply is provided to the TMS.

- Each fan may be configured for a different speed/temperature profile.
- 0-10V or Open Collector speed controlled type fans.
- Open Collector Tachometer, Open Collector Alarm or Relay Alarm type fans.
- Configurable Alarm actions (fan speed change, Alarm relays operate)
- Customer configurable or may be supplied programmed to required profile.
- Open Loop or Closed Loop control configurable option, Thermistor or 0-10V inputs.

2 Main Features

- Control of four wire fans (Power, 0V, Speed control, Tachometer/Alarm Relay).
- Supply Voltage covers 12VDC, 24VDC and 48VDC nominal (11-57 VDC).
- Open Collector PWM fan speed control, 11-57 VDC supply.
- 0-10V PWM fan speed control, 16-57 VDC supply
- Fan speed based on temperature profile, independent profile for each fan.
- Compatible with tachometer, Alarm Relay, Open Collector alarm type fans
- 1-4 Fans, separate plug connector for each fan.
- Fans powered via controller PCB, up to 11A total fan supply.
- Tachometer/Alarm monitoring of all 4 fans, configurable alarm actions.
- Temperature monitoring, configurable alarm actions.
- Thermistor inputs, 2 off, configurable selection to control each fan.
- Switch Inputs, 2 off, suitable for e.g. door alarms, test switch, fan boost.
- Relay alarm outputs, 4 off, Solid State Relays, contacts rated 60VDC, 100mA.
- [PRELIMINARY] Daughter board option for two off Power Relays, contacts rated 230VAC 10A.
- All TMS connections use plug-in connectors.
- Side connectivity for low profile.
- Alarm LEDs show different alarm states.
- Alarm LEDs visible from both top and side, sited close to the edge of the PCB.
- PC Interface for Configuration and Data Logging, electrically isolated.
- Low power consumption, typical 10mA running from 24V/48V supply.
- Enclosure, DIN rail mountable.
- Thermistor inputs may be configured to operate as 0-10V inputs.
- All configuration settings stored in memory, no switches / links / potentiometers.
- RS485 Interface, non-isolated. *
ebm-papst EC-Matrix compatible control interface. *
*(Supported in customer specific software only, contact ebm-papst.)
- Text based and Graphical(GUI) configuration interface available.



3 DC Supply

- Supply Voltage covers 12V, 24V and 48V ranges (11- 57 VDC) SELV
- Supply reversal protection for controller circuitry.
- Supply Current:
 - 25mA max for controller only, typical 10mA running.
 - 11A max steady state total current including fan supply.
- Earthing . no part of the controller or fan circuit is connected to Chassis/Earth.
- Suitable for use on positive or negative earth (-48VDC) systems.
- Green Power LED will pulse slowly when power connected.

3.1 Use with -48VDC supply

The TMS is compatible with -48VDC supplies typically used in telecommunications systems. Considerations for -48VDC supply use:

- 1) Connect -48V to Power Connector pin 2, and the more positive supply lead to pin 1.
- 2) The Thermistors, Fan Speed Control and Fan Tachometer lines are referenced to the negative supply lead. Irreparable damage is likely if these signal wires are allowed to connect to any Earthed metalwork.
- 3) Consideration should be given to fitting fuses in the negative supply leads.
- 4) The TMS is equipped with an electrically isolated configuration interface to protect the user's PC while using this interface.

4 Fan Interface

- Four-wire fans (Supply, 0V, PWM Speed Control, Tachometer/Alarm).
- For Fan Supply via PCB, each fan maximum 130W at 48V.
- Speed control output to fan, 0-10V or Open Collector PWM, configurable frequency
- (0-10V control requires 24 or 48V supply). Inverted control profile option.
- Tachometer Input from fan, Open Collector compatible 1-6 tachometer pulses / revolution or Open Collector Alarm (low for normal, open for Fan Alarm) or Relay Alarm type fan (closed for normal, open for Fan Alarm). Connect the fan Alarm Relay between Tachometer and 0V.
- The red Fan LED next to the Fan Connector will illuminate during Fan alarm.

5 Fan Control

5.1 Temperature profile

Temperature/Control profile is configurable, an example of a profile can be seen below

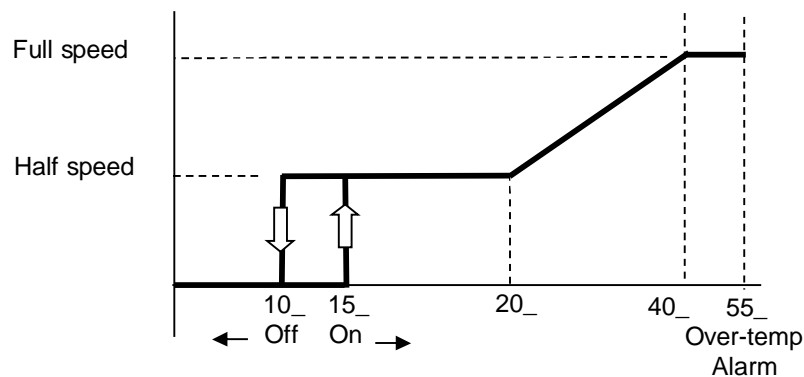

Each fan may have a different profile using either thermistor as configured. The fans can be set to switch off at low temperature, programmable option, individually programmable on and off points.



5.2 Multi-Point profile menu option

Optionally, the Temperature/Control Profile may be changed from the simple linear slope shown above to a multi-point profile. This allows intermediate points to be set on the slope.

5.3 Configuration

The TMS may be configured by connection to a PC using the configuration cable, see section [Configuration Cable](#) below, with either the PC running a Terminal Emulator program or a Graphical User Interface (GUI).

For both documents please download from www.ebmpapst.co.uk/instructions and select either;

- TMS terminal emulator program instructions
- TMS Graphical User Interface instructions

The unit may be configured by loading a previously created Configuration File, or by setting parameters individually. The new configuration may then be saved to a Configuration File.

Configurable settings, each set independently for each fan:

- Low temperature shut-off temperature points (enabled/disabled)
- Start of temperature control band and Top of temperature control band.
- Fan speed at defined temperatures.
- Configured to be controlled by either Thermistor 1 or Thermistor 2 or Both (highest of the two)
- May be set for higher speed at higher temperature ([Cooling profile](#)) or lower speed at higher temperature ([Heating Profile](#))
- Alarm temperature thresholds, configurable.
- Alarm actions can set each Fan Speed independently.
- Tachometer - the number of pulses per revolution may be configured in range 1-6 pulses/rev.
- The Fan Speed Control PWM Output may be set to 0-10V or Open Collector.
- The PMW output slope may be inverted, i.e. selectable between [PWM 0V out = fan off](#) and [PWM 0V out = fan full speed](#)

Global configurable settings, set for all fans together:

- Control mode Open Loop (set PWM Output) or Closed Loop (set Fan RPM)
- Thermistor inputs configurable as 0-10V inputs.
- Enable Relay Daughterboard.
- Enable Multi-Point temperature profile, see below.
- Fan Speed Control PWM Frequency
- Daily Fan Run
- Dummy Fan links Enabled/Ignored

5.4 Dummy Fan Links

If configured to [ALLOWED](#) a Dummy Fan Link ebm-papst part number 210-HAR12141 may be fitted to suppress alarms from an unfitted fan. The link presence is checked during power-up only.

Normally the link option would simply be configured to [Not Fitted](#), but this feature is used by users who prefer to have a single programmed configuration (i.e. single TMS variant) for applications with different quantities of fans, as this reduces their spares holding requirement. A Fan or Link is then connected as required on a per site basis.

5.5 Daily Fan Run

The Fans may be configured to shut off at low temperatures (common in street cabinet applications). In order to have confidence that the fans will restart after what may be an extended off period in adverse conditions, the fans may be configured to briefly run once per day for test, even though remaining below the configured shut-off temperature.



5.6 PWM Frequency

The fan speed control PWM frequency may be varied if required for the fans being used, see fan data sheet. Most fans will operate correctly at the default value.

6 Alarms

6.1 Alarm Interface

Solid State Relays, contact rating 0.1A, 60VDC. Single contact per relay either open or closed, (no Change-Over contacts on board).

Alarm Relay default setting:

- Contact closed in normal operation (alarm inactive),
- Contact will open for alarm active including power fail (fail safe operation).

Option to invert relay operation so contacts close when alarm active and open for no alarm, except relay contacts always open when unit not powered.

Relays may be configured to change state on Fan Alarm or Temperature Alarm or Switch Input, or 0-10V input voltage if selected instead of Thermistor. Other Relay option, see below. Red Alarm LED will illuminate when one or more of the configured alarm criterion is active.

6.2 Alarm Criterion

Supply power fail . all relay contacts open, all Alarm LEDs off.

An alarm may be raised in the event of any of the following, configurable by program:

- 1) One or more fan(s) failed . defined as not achieving set speed, within tolerance.
- 2) Either thermistor indicates temperature (configurable threshold, configurable to alarm Above or Below threshold)
- 3) Thermistor input open or short circuit
- 4) Temperature differential between thermistors (configurable threshold)
- 5) Switch Input High/Low, configurable.
- 6) 0-10V input voltage level if TMS configured for 0-10V input instead of Thermistor.

The temperature alarm threshold incorporates hysteresis. The Fan Fail alarm incorporates a delay.

6.3 Alarm Actions

In the event of an alarm the following actions are configurable by program:

- 1) Alarm Relay contacts change (for power fail all relay contacts open)
- 2) Depending upon failure other fans will react to compensate, configurable by program.
- 3) Alarm Fan Speed setting overrides temperature based speed control for the duration of the alarm.

Alarms are non-latching.

6.4 Fan Fail Criterion

Fan Fail+ defined as fan not reaching set speed (within tolerance) within a set period. If the PWM output is set below 20% the Fan Fail alarm will be inhibited, to allow for undefined operation around the fan start-up point.

Note:

The Fan Tachometer alarm is configurable to be inhibited on a per-fan basis, may be used when connected to a fan with no Tachometer or other Open Collector / 0-10V controllable device.

6.5 Alarm LED Indications

Alarm LED indication of power/fan/thermistor/Expansion board fail.



7 Environment

Operating Temperature range -40_C to 70_C

Operating Humidity range 0-95% Non Condensing at 40°C max

8 EMC Compliance

Radiated Emissions BS EN55022:2006, Class B

Radiated Immunity EN61000-4-3:2002 +A1+A2

Fast Transient Bursts EN61000-4-4:2004

Conducted Immunity EN61000-4-6:2007

Notes:

- 1) No filtering of fan supply or fan supply inrush limiting provided.
- 2) It is recommended that sensor and control cables over 3m length are screened.
- 3) Route sensor and control wiring separately from AC mains wiring
- 4) Any connection to a DC Distribution Network should be made via an EN61000-4-5 compliant interface

9 Safety

Compliant with EN60950. All plastic components used on the controller are Flammability rating UL94V-0 or better.

Installation must be by qualified personnel in accordance with local applicable standards.

This appliance is intended to be enclosed in the equipment and not accessed by the user.

Access is limited to service personnel only. Residual risk of contact with fan. Maintenance personnel should take due care and attention.

10 RoHS

The controller is RoHS compliant.

11 Fuses

- Auto-resetting fuse for controller supply.
- Fan supply not fused, relies on external fusing.
- The controller must be powered from a 15A maximum fused supply.

12 Switch inputs

- Isolated switch contact or open collector compatible (referenced to negative supply lead). Quantity two.
- Pull-up resistor on controller PCB.
- Suitable for e.g. door alarms, test switch, fan boost.
- Configurable to change Fan speed or change Alarm Relay state.

13 Mechanics, Enclosure

- Cover / guard to prevent accidental contact with controller.
- Connectors accessible and Alarm LEDs are visible with cover fitted.
- The following connectors mounted along one edge of PCB:
 - Power, four Fans, two Thermistors, one Relay Alarm Output
- Other connectors mounted on opposite edge:
 - Three Alarm Relays, RS485, Relay Daughterboard connector, two switch inputs.
- Configuration connection at end.
- Enclosure Length = 143mm
- Enclosure Width = 65.5mm



- Enclosure Height = 23mm
- Fixing Hole Size 3.5mm diameter (4 off)
- Fixing centres 134x55mm

980-CAS11007, Controller PCB Dimensions:

119x65.5mm

Fixing Hole Size 3.5mm diameter (4 off)

Fixing centres 110x53mm.

Weight: PCB plus enclosure = 170g

13.1 DIN Rail Mounting

The TMS enclosure is fitted with 2 holes 4.1mm diameter on 134mm centres designed to accept DIN mounting clips as shown in the diagram below. The fixing holes are compatible with DIN mounting clip Weidmuller part number 0687900000. Fixings required M4 screws length 8mm, plus spacers (e.g. M4 nuts).



14 Identification of Connectors, LED's and Pin Numbering

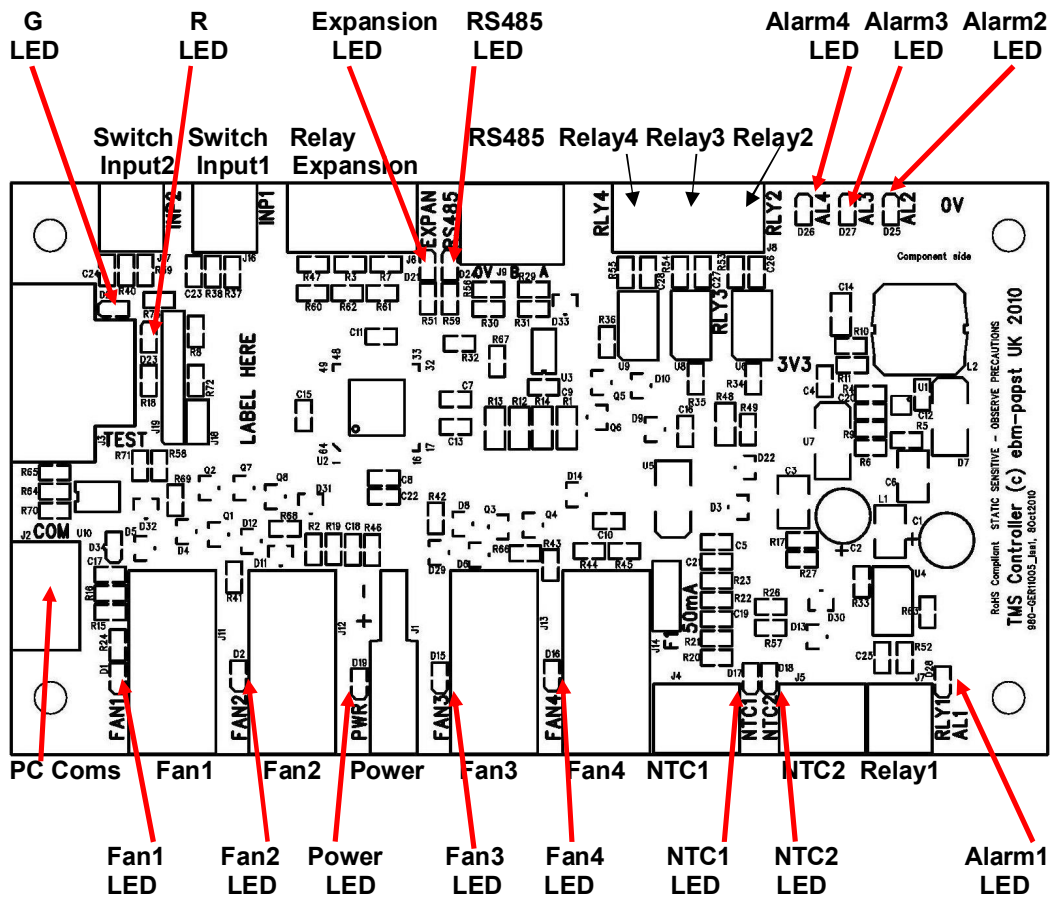

14.1 Connectors, front edge of PCB, pin numbering

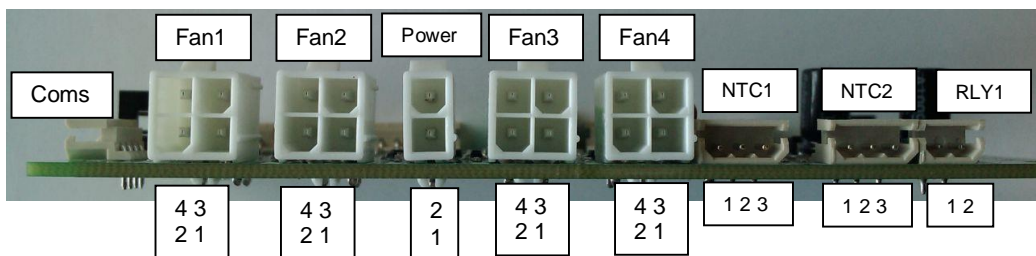

14.2 Connectors, rear edge of PCB, pin numbering

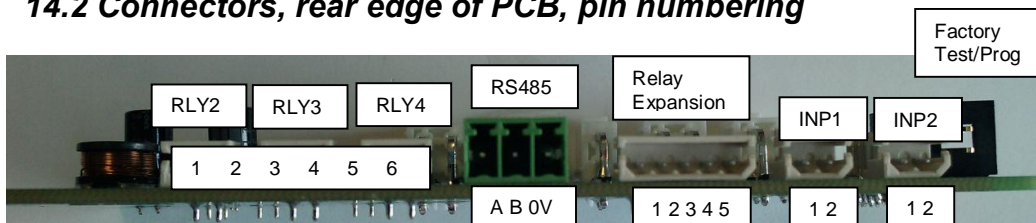



15 Mating Connector Types and Pin Configuration

FRONT EDGE CONNECTIONS

Power Input

Molex 39-01-2025, 4.20mm (.165") Pitch Mini-Fit Jr Receptacle Housing, Dual Row, UL 94V-0, 2 Circuits

Pin 1 = Positive supply +11 to +57V
Pin 2 = 0V

(For -48V supplies see section "Use with -48VDC supply")

Fans

Molex 39-01-2045, 4.20mm (.165") Pitch Mini-Fit Jr Receptacle Housing, Dual Row, UL 94V-0, 4 Circuits.

Pin 1 = 0V (connected to Power connector pin 2)
Pin 2 = +11 to +57V Out (connected to Power connector pin 1)
Pin 3 = PWM Output, Fan Speed Control
Pin 4 = Tachometer Input (For Relay Alarm fans connect relay between this pin and 0V)

Crimps for Power and Fan Connectors

Standard Crimp:

Molex 39-00-0039, 4.20mm (.165") Pitch Mini-Fit Crimp Terminal, Female, with Tin (Sn) over Copper (Cu) Plated Brass, 18-24 AWG, Bag. Up to 9A with 18AWG wire.

High Current Crimp:

Molex 0457503112, Mini-Fit Plus HCS Crimp Terminal 45750, 16 AWG, Bag, Copper (Cu) Alloy, Tin (Sn). Up to 11A with 16AWG wire.

Thermistors and 0-10V Inputs

Molex 50-37-5033 - CRIMP HOUSING, 2.5MM, 3WAY

Thermistor connection

Pin 1 = Thermistor terminal 1
Pin 2 = no connection
Pin 3 = Thermistor terminal 2

(Thermistor has no polarity connection requirement)

Alternative connection for 0-10V input use

For 0-10V Input+operating modes only:

Pin 1 = no connection
Pin 2 = 0V (connected to Power connector pin 2)
Pin 3 = 0-10V

Relay Outputs, Relay 1

Molex 50-37-5023 - CRIMP HOUSING, 2.5MM, 2WAY

Pin 1 = Relay 1 terminal 1
Pin 2 = Relay 1 terminal 2



REAR EDGE CONNECTIONS

Relay Outputs, Relays 2-4

Molex 50-37-5063 - CRIMP HOUSING, 2.5MM, 6WAY

Pin 1 = Relay 2 terminal 1
Pin 2 = Relay 2 terminal 2
Pin 3 = Relay 3 terminal 1
Pin 4 = Relay 3 terminal 2
Pin 5 = Relay 4 terminal 1
Pin 6 = Relay 4 terminal 2

Relay Expansion

Molex 50375053 - CRIMP HOUSING, 2.5MM, 5WAY

Standard ebm-papst EC-Matrix compatible control interface pin-out, plus 12/24/48V Power.

Switch Inputs 1-2

Molex 50-37-5023 - CRIMP HOUSING, 2.5MM, 2WAY

Pin 1 = Switch input (Volt Free or Open Collector Compatible). On-board pull-up resistor.
Pin 2 = 0V (connected to Power connector pin 2)

Crimps for NTC Thermistors, Relay Outputs, Switch Inputs, Relay Daughterboard and Configuration Interface

Molex 08-70-1040, 2.50mm (.098") Pitch SPOXi Crimp Terminal 5263, 22-28 AWG, Bag

RS485 Interface (Customer specific software use only.)

IMO Precision Controls - 20.1550M/3 - Terminal Block, 3.5MM, 3WAY

Connections:

Pin A = RS485 A
Pin B = RS485 B
Pin 0V = 0V

END CONNECTIONS

Coms - Configuration and Monitoring Interface

Molex 50-37-5043 - CRIMP HOUSING, 2.5MM, 4WAY

Pin 1 = 5V input
Pin 2 = Serial Out, 3V3 Logic level
Pin 3 = Serial In, 3V3 Logic level
Pin 4 = 0V

Connections are electrically isolated from TMS circuit.

Designed for connection of cable assembly ebm-papst part number 210-HAR11887

Test Connector

Factory use only. For reprogramming Microcontroller program.



16 Thermistors

NTC (Negative Temperature Coefficient) Thermistor, 100k Ohm at 25C. Thermistor manufacturer's part number Vishay 238164063104. Thermistor contacts must be insulated to prevent contact with chassis. The TMS is configurable to use either one or two thermistors. (Note . Thermistor type differs from HMS Controller).

16.1 Thermistor Cable Assembly Accessory

A thermistor cable assembly consists of a compatible insulated Thermistor, wired to Thermistor Connector pins 1 and 3.

Thermistor Cable Assembly Part Number	Cable Length mm
210-HAR12280	120
210-HAR12145	300
210-HAR12302	2000

17 Relay Daughterboard Accessory (PRELIMINARY)

An optional Relay Daughterboard may be connected to the Expansion Connector, relays controlled by the TMS controller. 10A/250VAC relay contact rating.

There are 24V and 48V variants of the Relay daughterboard, dependant on the supply. When operating correctly, the Power LED on the Relay Daughterboard will pulse in time with the Power LED on the TMS.

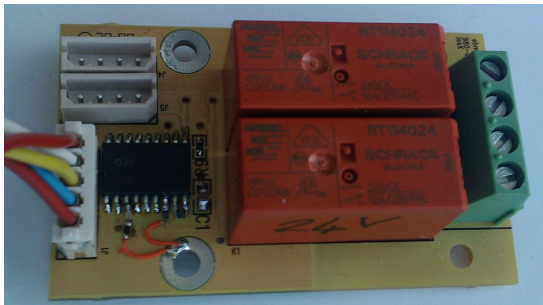

The interface used is compatible with the ebm-papst EC Matrix+control bus, support for other EC-Matrix boards possible, contact ebm-papst.

Relay Daughterboard Part Number	TMS Supply Voltage
N/A	12V
980-CAS11659	24V
980-CAS11470	48V

18 Dummy Fan Link Accessory

Dummy Fan Link ebm-papst part number 210-HAR12141. This comprises a fan connector with pins 3-4 linked (TMS PWM output linked to Tachometer Input).



19 Configuration Cable Assembly Accessory



ebm-papst part number 210-HAR11887, type A USB to TTL serial data adapter, length 1.8m. Connects TMS to PC for configuration and data logging.

20 Development Cable Set Accessory

Development Cable Set Accessory ebm-papst part number 210-HAR13100. This consists of a TMS power cable, 4 off fan cables, alarm cable and switch input cables. The cables consist of the required mating connector for the TMS connection, the other end of the cable being unterminated to allow the user to connect as they require. This is intended for development or evaluation use, particularly by customers that do not have tools to fit the necessary connector crimps. **Supports up to 7.5Amps total current.**

21 Fan Compatibility and example recommended settings

- Four wire type fans (Power, 0V, Speed control, Tachometer/Alarm).
- Fans may be a mix of 0-10V PWM type and Open Collector PWM speed controlled type.
- PWM profile: The PWM output may be inverted, i.e. selectable between %PWM 0V out = fan off+and %PWM 0V out = fan full speed+
- Tachometer - the number of pulses per revolution may be set for each fan, 1-6 pulses/rev, Open Collector compatible interface.
- The TMS may also be used with mains powered EC Fans with 4 wire control connection (10V, 0-10V speed control, Open Collector Tachometer, 0v connection), provided that a 12-48V supply is provided for the TMS. Both the EC Fan 10V output and TMS Fan connector pin2 would be unused.
- High current fans may be controlled (over 11A total current), route power directly to the fan.

All tachometer type fans to be controlled using "Temperature sets PWM Output (Open Loop)% or "0-10V input sets PWM Output (Open Loop)+modes must have an approximately linear internal control profile, i.e. 100% speed at 100% PWM, 50% speed at 50% PWM. Fans with an internal control profile that differs too far from this will generate spurious alarms.

This restriction does not apply to Relay Alarm type fans or when using the "Temperature sets Fan RPM (Closed Loop)+or "0-10V input sets Fan RPM" (Closed Loop)+modes.

21.1 Recommended Fan Settings

Note: The following information is presented as a guide, in all cases the latest issue of the fan data sheet should be consulted.



For ebm-papst St.Georgen fans only (identified by %St.Georgen+ on the fan rating label), the Tachometer Pulses per Revolution may be determined by these rules :

- 1) Part numbers ending with the letter %Q+ always have three Tachometer Pulses per Revolution and are 0-10V control input. This rule overrides all other rules below.
- 2) Part numbers 4100 NH7 and NH8 e.g. 4114N/2HP8 have three Tachometer Pulses per Revolution.
- 3) All TD part numbers excluding 6400 TD have six Tachometer Pulses per Revolution.
- 4) All other St.Georgen fans have two pulses per revolution
- 5) Note - after 2012 consult the updated catalogue.

The speed control input is 0-10V for part numbers ending with the letter %Q+, others are Open Collector.

For ebm-papst Mulfingen fans (identified by %Mulfingen+ on the fan rating label), the speed control input is normally 0-10V, Tachometer output either 1, 2 or 3 pulses / revolution.

Some example fan settings are shown in the table below. These fans have been tested and confirmed to be compatible with the TMS controller.

Failure to set configuration correctly can lead to spurious alarm generation and anomalous fan behaviour.

Fan Type	Voltage	Tachometer Pulses per Revolution	Maximum RPM setting	PWM Frequency kHz	Control Type 0-10V or Open Collector
2214F/2TDHHO	24	3	5000	2kHz	0-10V
2214F/2TDHO	24	3	4250	2kHz	0-10V
2218F/2TDH4P	48	6	6500	2kHz	Open Collector
2218F/2TDHHO	48	3	5000	2kHz	0-10V
3212J/2H4P	12	2	13000	2kHz	Open Collector
3214J/2H4P	24	2	13000	2kHz	Open Collector
3218J/2H4P	48	2	13000	2kHz	Open Collector
4114N/2H7P	48	3	9500	2kHz	Open Collector
4114N/2H8P	24	3	11000	2kHz	Open Collector
4118N/2H7P	24	3	9500	2kHz	Open Collector
4118N/2H8P	48	3	11000	2kHz	Open Collector
5312/2TDHP	12	6	6000	2kHz	Open Collector
5314/2TDHHP	24	6	7000	2kHz	Open Collector
5314/2TDHP	24	6	6000	2kHz	Open Collector
5318/2TDH4P	48	6	9200	2kHz	Open Collector
6312/2TDHP	12	6	5500	2kHz	Open Collector
6314/2TDHHP	24	6	7000	2kHz	Open Collector
6314/2TDHP	24	6	5500	2kHz	Open Collector
6318/2TDH4P	48	6	9200	2kHz	Open Collector
6318/2TDHHP	48	6	7000	2kHz	Open Collector
6318/2TDHP	48	6	5500	2kHz	Open Collector
8212J/2H4P	12	2	14000	2kHz	Open Collector
8214J/2H4P	24	2	14000	2kHz	Open Collector
8218J/2H4P	48	2	14000	2kHz	Open Collector



8412N/2GHP	12	2	3600	25kHz	Open Collector
8414N/2HP	24	2	3600	25kHz	Open Collector
G1G108-AB17-02	24	2	3000	2kHz	0-10V
R1G175-AF29-04	48	2	4000	2 kHz	0-10V
K1G190-AB25-02	48	2	2950	2 kHz	0-10V
RER175-42/18/2TDMP	48	6	4800	2 kHz	Open Collector
R1G310-AA33-52	48	3	1520	2 kHz	0-10V
D3G133-BF03-06	230VAC	1	1260	2kHz	0-10V

22 TMS / HMS Controller, summary of differences

The HMS controller was supplied by ebm-papst prior to the TMS becoming available. The following information is provided for customers who previously used the HMS controller.

- 1) TMS is supplied with Enclosure, DIN rail mountable with addition of clips.
- 2) TMS is smaller.
- 3) TMS is may be used with both 0-10V & Open Collector speed control fans.
- 4) TMS is compatible with both 0-10V & 10-0V (i.e. reversed speed control profile) fans.
- 5) Tachometer pulses per revolution limited to 1-3 on HMS, 1-6 on TMS, TMS compatible with ebm-papst S-Force fans.
- 6) TMS may be used with Relay Alarm or Open Collector alarm (no Tachometer) fans
- 7) TMS may be used with 12V fans (Open Collector Control)
- 8) TMS has programmable Alarm on difference between temperatures of Thermistor 1 & Thermistor 2.
- 9) TMS has Alarm Indicator LED's on board.
- 10) TMS configuration cable uses USB connection, HMS used RS232, ports 0-3 only (generally the HMS must be configured using a PC with built-in Serial Port, USB-RS232 Serial adapters not supported).
- 11) TMS accepts "Fan not fitted" dummy fan link in place of fan, customer can have e.g. 4 Fan s/w version programmed then fit number of fans as required without reprogramming / unwanted alarms.
- 12) TMS PWM frequency configurable.
- 13) TMS has %Daily Fan Run+, configurable option.
- 14) TMS %Fan Fail+ alarm action is configurable to monitor selected fans, HMS monitors all or none.
- 15) TMS has 0-10V input option
- 16) TMS has %File Logging+data output feature
- 17) TMS Thermistor type differs from HMS Controller.



23 CE Certificate, copy of front sheet



Part No - 980-CAS11007

0093

Certificate No - 980-CAS11007CE

CE DECLARATION OF CONFORMITY		
Declaration		
We, ebm-papst UK Ltd, Chelmsford Business Park, Chelmsford, Essex CM2 5EZ certify that the product(s) listed are in conformity with;		
Low Voltage Directive 2006/95/EC Electromagnetic Compatibility Directive 2004/108/EC		
	Declaration Approved	Technical File Compiled
Name	G. M. Lockwood	Jeff Elkins
Position	Technical Director	Electronics Design Engineer
Signature		
Date of Declaration	23-Jan-2011	23-Jan-2011
Part number:	980-CAS11007	
Description:	Fan speed controller and monitor, 48V DC	
<p>The product(s) have been assessed by the application of the following Standards;</p> <p>BS EN 60950-1 - Information technology equipment. Safety. General requirements</p> <p>BS EN61000-6-3:2007 (emissions) BS EN61000-6-2:2005 (immunity) Radiated Emissions BS EN55022:2006, Class B Radiated Immunity EN61000-4-3:2002 +A1+A2 Fast Transient Bursts EN61000-4-4:2004 Conducted Immunity EN61000-4-6:2007</p>		