

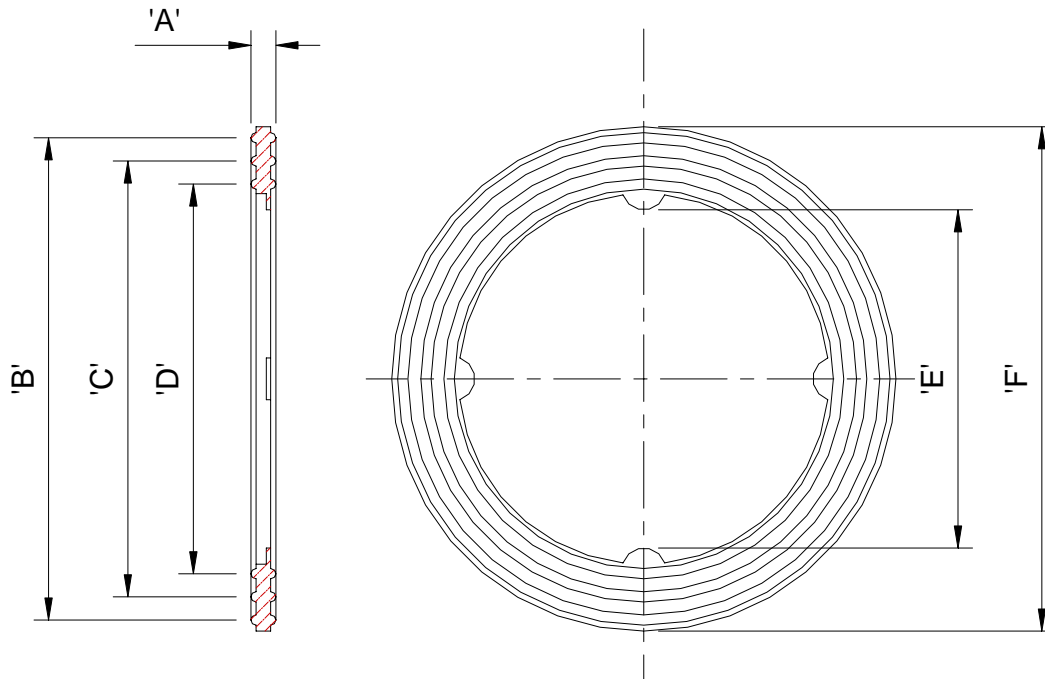

## NYLON WASHERS FOR USE WITH HAZARDOUS AREA EQUIPMENT



CONDUIT SIZE (mm)	U.S. TRADE SIZE (inches)	ORDERING CODE	DIMENSIONS (mm)					
			Thickness 'A'	Outer Ring Dia 'B'	Middle Ring Dia 'C'	Inner Ring Dia 'D'	Dim 'E'	O/D 'F'
16	3/8	EXFM03	1.6	20.6		18.4	14.5	22.0
20	1/2	EXFM04	1.6	24.6		22.4	18.5	26.0
25	3/4	EXFM05	1.7	32.8	29.65	26.5	23.0	34.3
32	1	EXFM06	1.7	40.0		33.5	30.0	41.5
40	1.1/4	EXFM07	2.0	50.0	46.5	43.0	39.2	52.0
50	1.1/2	EXFM08	2.0	64.0	59.0	54.0	48.0	66.5
63	2	EXFM09	2.0	82.0	74.5	67.0	62.0	84.5

Washers EXFM03, EXFM04 AND EXFM06 only have two seal protrusions

**MATERIAL:**  
**NYLON 66**

**TEMPERATURE RATING**  
**-70°C to +150°C**  
**Continuous use**

