

Assembly Instructions

For C type Connectors used with Kopex
Pliable Conduits (Optional Screening)

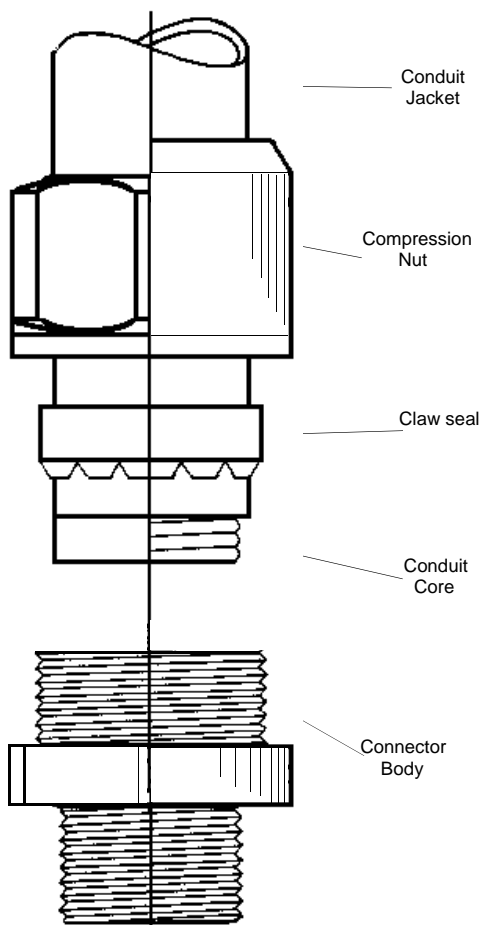

1. Cut the conduit square with a knife edge blade.
2. **If screening is required**, remove conduit jacket equal to length of body taper.
3. Dismantle the connector.
4. Assemble the nut and claw seal loosely on the conduit end.
5. Push the conduit down into the connector body, ensuring the core makes contact with the taper in the body when screening is required.

