

## ST699 ELECTRONIC DUAL ZONE TIMER

### PRODUCT DATA

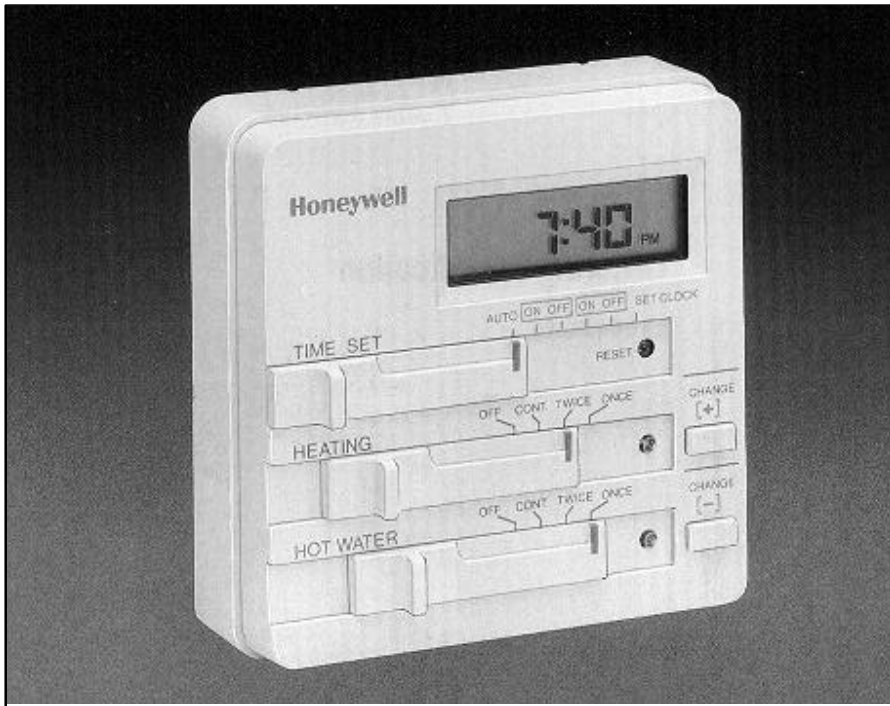

The ST699 electronic dual zone timer is used to control gravity, primary or fully pumped central heating systems requiring a single 24 hour programme with two ON/OFF periods per day.

ST699 incorporates a simple and intuitive programming concept which established its predecessor as the leading electronic dual zone timer on the market.

ST699 is designed for European CEN approval.

### FEATURES

- 24-hour programme
- Independent heating and hot water channels
- One or Two ON/OFF periods per day
- Built-in programme
- Temporary programme override/advance
- 7-day battery back-up
- Compact size
- AM/PM or 24 hour clock format (factory option)
- Wallplate compatibility with 7-day version (ST799)
- 10 minute programme resolution
- 3 A resistive/inductive (@ 0.6 pf) 230 V~ SPDT relay rating
- Simple/intuitive programming
- Surface or wallbox mounting options
- Pack contains everything for immediate installation

## SPECIFICATIONS

Product type	: Electronic dual zone timer
Power supply	: 230 V~ (±10%), 50 HZ
Power reserve	: Rechargeable battery with 7 days backup following a 24 hour charging period
Switch rating	: 2 x SPDT potential free 3 A resistive @ 230 V~ (± 10%), 50 Hz 3 A inductive @ 0.6 pf
Programme	: 24-hour with two ON/OFF periods daily
Programme resolution	: 10 minutes
Programme day	: 03.00 AM to 02.50 AM (on the next day)
Override	: Advance next programme time (change)
Wiring	: Surface or single wallbox (UA1 size)

Wiring access	: Rear or bottom edge (surface wiring access)
Wire gauge	: 0.75 to 2.5 mm <sup>2</sup> two max. per terminal
Dimensions	: 100 x 100 x 38 mm (w x h x d)
Protection class	: IP20 (IEC 529)
Environmental	: Operating temperature range 0 to 45°C Shipping and storage temperature range -20 to 55°C Humidity range 0 to 90% rh, non-condensing
Approvals	: Designed to meet European CEN approval EN60730
Life	: 7 years minimum

## DIMENSIONS

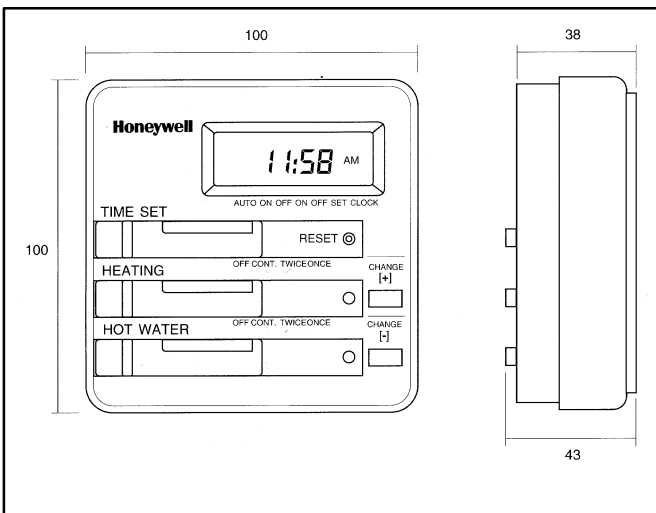

## ORDERING SPECIFICATION

ST699B1002

## INSTALLATION

### Mounting

Remove the subbase from the timer by depressing the securing clip A and pulling the two halves apart. See fig. 1

The ST699 can either be mounted onto the wall surface or a flush mounted UA1 (with 60.3 mm pitch mounting holes) using the screws supplied.

### IMPORTANT

1. The installer must be a trained service engineer
2. Disconnect the power supply before beginning installation

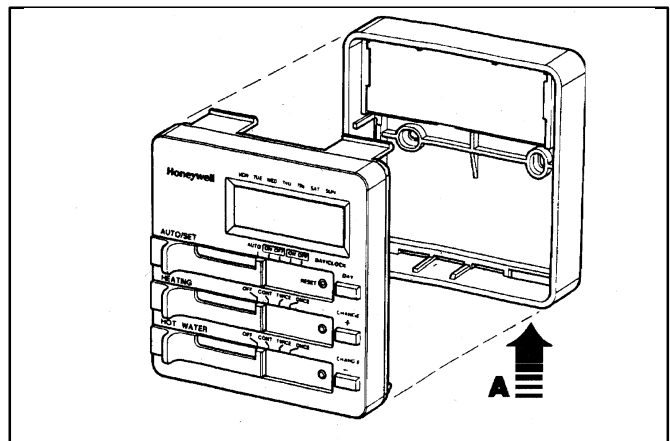

Fig. 1

# WIRING

Cable entries can be made through the opening in the rear of the subbase, or via the three surface entry break-outs in the top and two sides of the wallplate. See fig. 2

The ST699 is designed for fixed wiring only and must be wired in accordance with the latest IEE wiring regulations.

Ensure the wiring connections to the mains supply is via a fuse rated at not more than 3 A and a Class "A" switch (having contact separation of at least 3 mm in all poles).

Remove the terminal cover to allow access to the wiring terminals as shown in fig.2. Connect the systems wiring as shown by the specific applications wiring diagram. A maximum of two 2.5 mm<sup>2</sup> (cross sectional area) wires can be connected to each terminal as shown in fig.3. Each wire should be stripped of insulation to a length no greater than 7mm to safeguard against the possibility of electrical shorts.

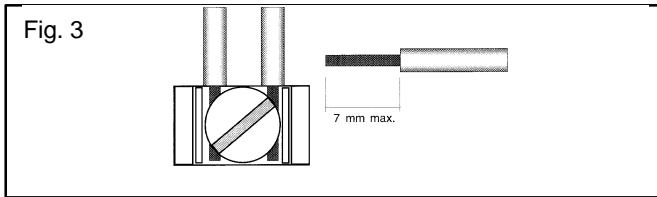
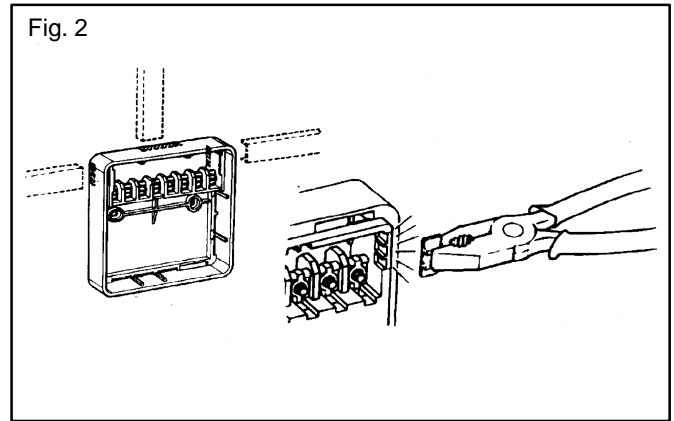

## Systems Wiring

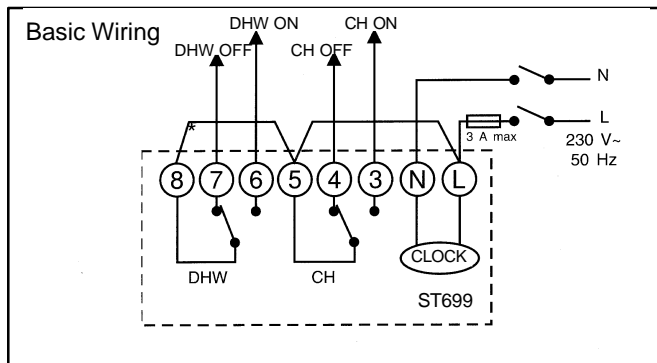

\*A link must be provided between L-5-8 on the subbase of ST699 for all Sundial Plans, or fully controlled pumped primary systems

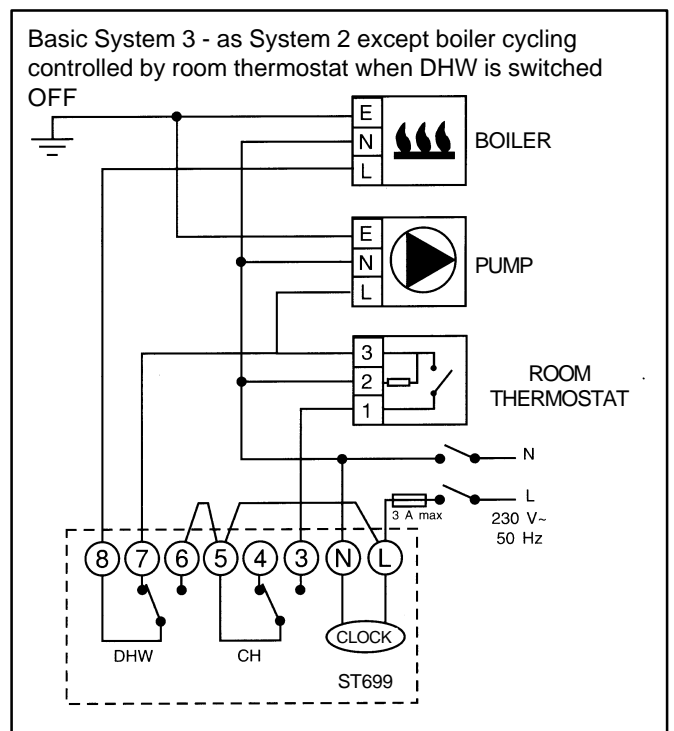
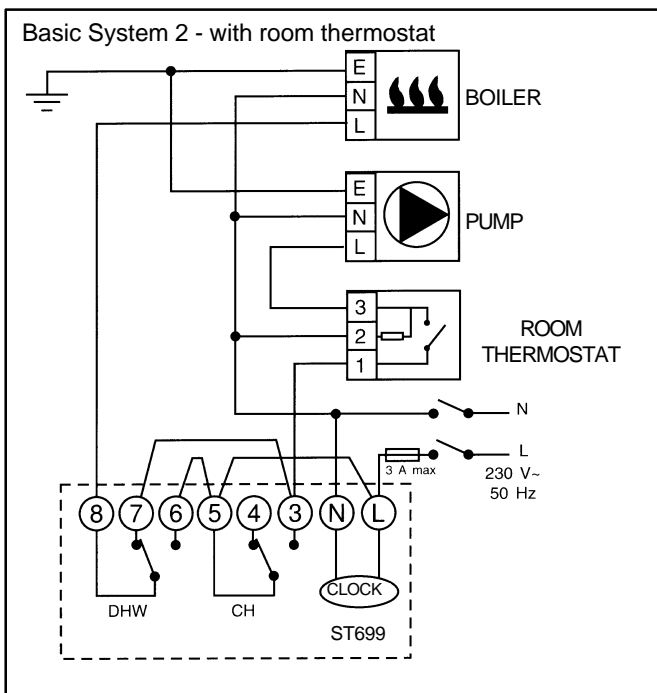
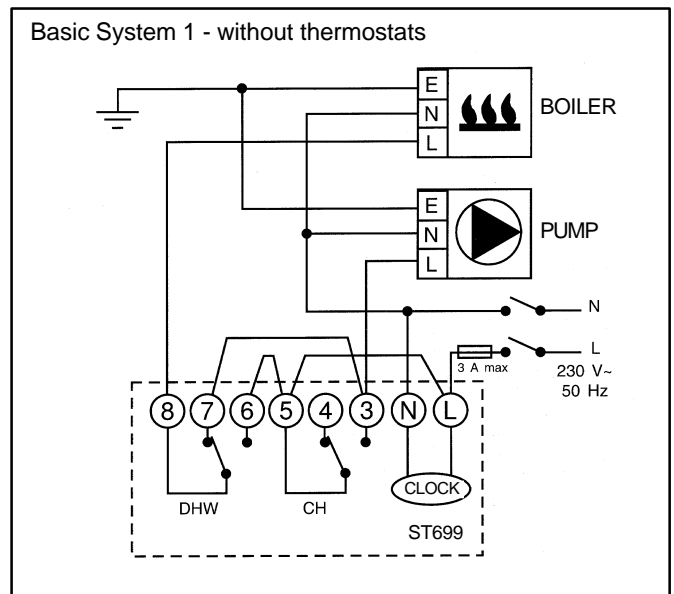

# SUNDIAL PLAN WIRING DIAGRAMS

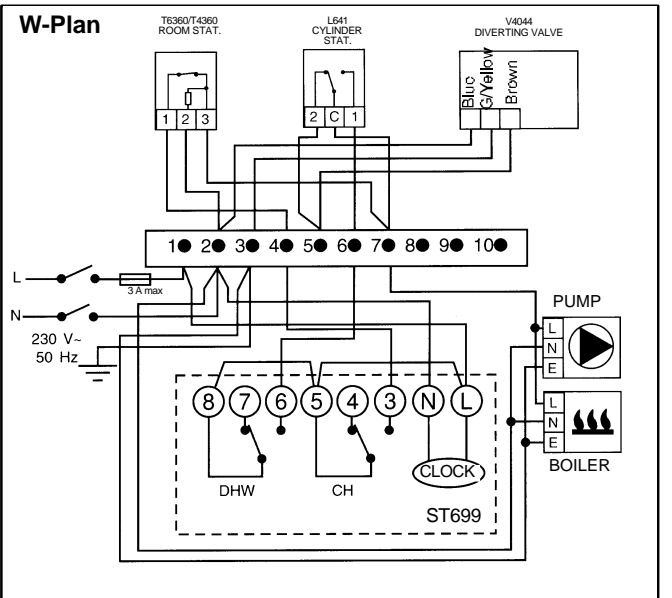
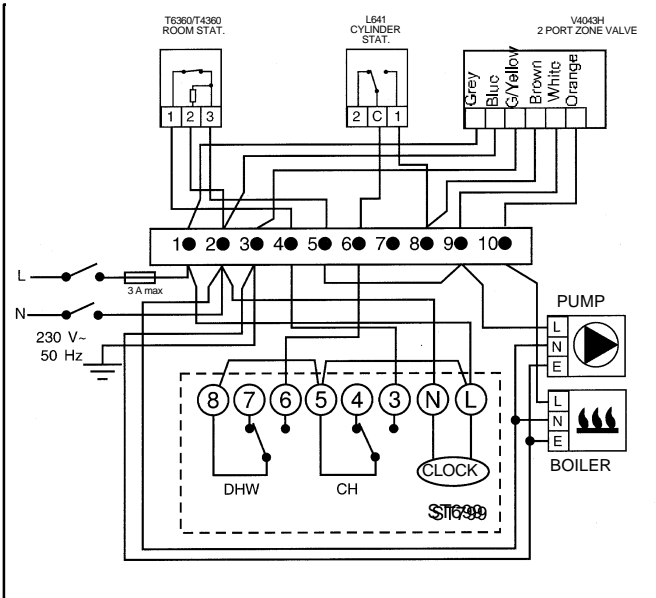
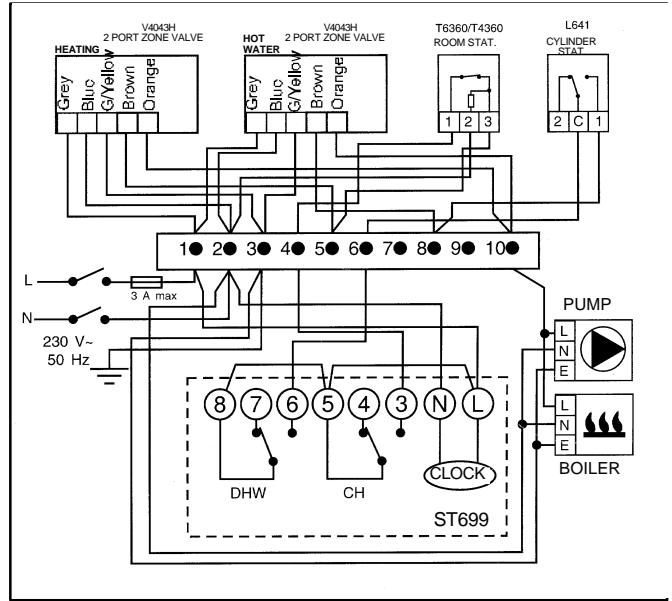
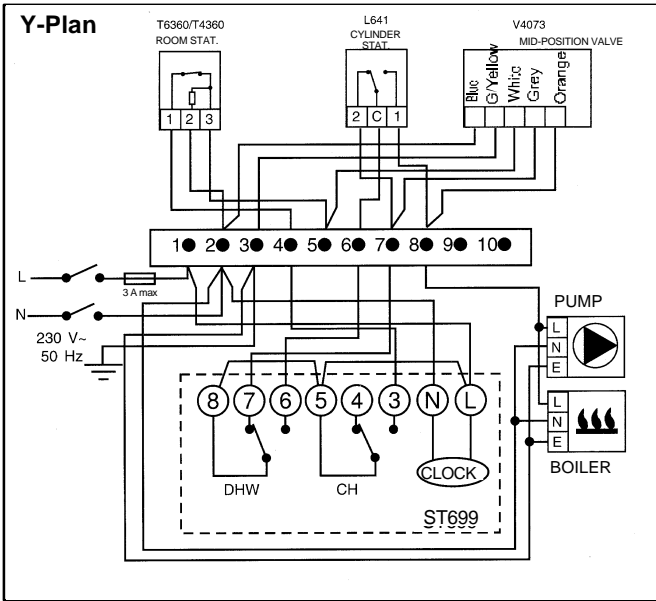

**NOTE:** In the Sundial S, W, and Y Plan wiring diagrams, connections are shown to basic boilers only. For wiring connections to pump overrun boilers refer to boiler manufacturers instructions or Honeywell for assistance.

## Final Assembly

When the wiring is completed, replace the terminal cover ensuring it is correctly installed with ends located under the tabs and the locking pin through the locating hole.

Replace the timer onto the wallplate, ensuring it is firmly secured by the three securing clips.

Switch on the power and refer to the user's guide for programming details.

**If the display remains blank, press the RESET button with a blunt object. (e.g. a pencil)**

**Honeywell**