

# SmartFan<sup>®</sup> Vortex

I2C Speed Control for 12 VDC Fans

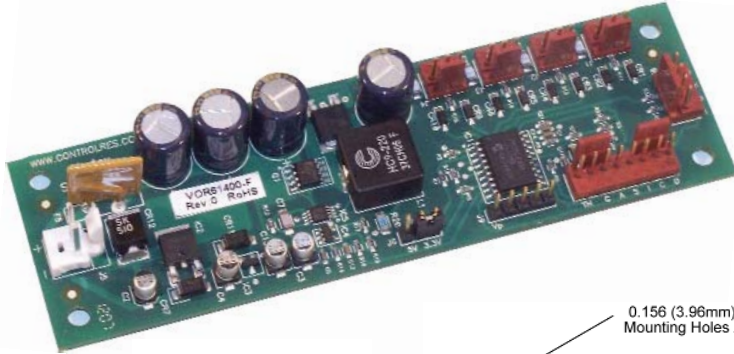

P/N VOR5I400-F

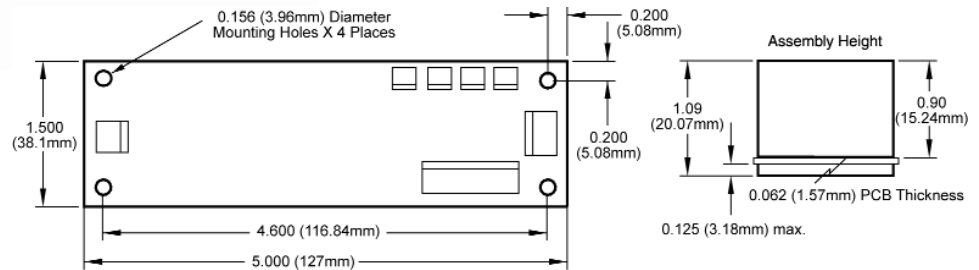

**SmartFan Vortex** is an I2C fan speed control and alarm designed for 12 VDC fans. Vortex can control and monitor tach pulses from up to four fans. The controller accepts fan speed commands (including on/off) and provides individual pass/fail fan status via an I2C interface. Fan speed can also be based on temperature. The I2C interface also provides temperature readings from an on-board thermistor and EEPROM storage. Voltage to the fans is varied using a current mode buck control circuit. Vortex is compatible with fans that provide open collector or voltage source tach pulses

## SPECIFICATIONS

- Power Source: 12 VDC (+/- 20%)
- Current Rating: 5 Amps @ 55°C or less
- Fans: up to four 12 VDC fans
- Fan speed based on:
  - I2C interface
  - Temperature at an on-board or remote thermistor
- I2C interface capability:
  - Set fan speed control to be based on temperature or I2C commands
  - Write fan speed commands (including on/off)
  - Read pass/fail status for each fan
  - Read temperature readings from an on-board thermistor
  - Allow access to EEPROM storage
- Temperature accuracy and hysteresis: 2°C

## FEATURES

- High power efficiency, typically greater than 90%
- Fan voltage adjustment is accomplished with a current mode buck control circuit. Fans can also be turned off.
- Monitors open collector or voltage source tach pulses from the fans and provides pass/fail status for each fan through the I2C interface
- Optional individual fan fusing
- Small size of 1.5" X 5.0" permits mounting in small spaces within fan trays, etc.
- RoHS compliant
- For mounting and connecting hardware order Hardware Pack P/N H122-F

# SmartFan Vortex Datasheet

## FEATURES

**Input Power:** The Vortex accepts a 12 VDC (+/-20%) power source and can supply up to 5.0 Amps to the fan load with natural convection at 12 VDC.

**Fan Speed Control:** The speed of all fans is varied by adjusting the fan voltage. Voltage adjustment is accomplished with a current mode buck-only control circuit. The fan voltage range is 0-12 VDC for 12 VDC fans.

**Input Power Fuse:** A 7.5 Amp re-settable input power fuse is provided to protect the Vortex from over-current conditions.

**Soft Start:** The voltage applied to the fans at start-up ramps from 0 to 12 VDC for 12 VDC fans. After this period, the fan voltage moves to the commanded voltage. This “soft start” feature limits the current spike common to DC fans at start-up.

**Number of Fans:** The Vortex can be configured to power and monitor 1 to 4 fans.

**Fan Control Methods:** Two methods of controlling the speed of the fans are settable via the I2C Bus: Temperature Sensor (thermistor) input or I2C Bus input. Following is a description of each control method:

**1) Temperature Based Fan Control:** The speed of all fans is proportional to the temperature sensor connected to header J7, or the temperature of the board mounted sensor. Chart 1.0 shows fan voltage as a function of sensed temperature. I2C Bus register 0xF8 is used to set the control temperature,  $T_c$  (The control temperature is the temperature at which full supply voltage is applied to the fans.). Temperature sensor status and temperature readings are available on the I2C Bus.

**2) I2C Bus Based Fan Control:** When an I2C speed command is given, the Vortex automatically switches to I2C control mode for fan control via the I2C Bus. The speed of all fans is mapped to the command sent through the I2C on header J7. See the Operation Section for a full definition of the I2C protocol.

**Number of Temperature Sensors:** When temperature sensor based fan control is specified, the user can choose to control based on the remotely mounted sensor or the board mounted sensor.

**Selectable Control Temperature and Slope:** When temperature sensor based fan control is specified, the user can set the control temperature and choose a 5°C or 10°C slope via the I2C Bus.

**Selectable Off Temperature:** When temperature sensor based fan control is specified, the user can select an off temperature which will set the fan voltage to 0 VDC when the temperature drops below the set point.

**Selectable Alarm Temperature:** When temperature sensor based fan control is specified, the user can set the alarm temperature. When the temperature exceeds the alarm temperature, an alarm is triggered and full supply voltage is applied to the fans.

**On Board Power Supply:** 3.3 or 5.0 VDC power to run the I2C Bus can be selected by the jumper setting on J6. The Vortex uses a common negative ground for all power and signal connections.

### Standard Configuration of the Vortex

The Vortex is intended to be configured via an I2C Bus. If no I2C Bus is connected the Vortex will default to temperature based speed control as follows.

- Temperature is monitored by the on-board/remote sensor
- Control (full speed) temperature is 40°C
- Temperature slope is 5°C
- Idle speed (temperature below 35°C) is ~13 VDC
- Fan alarm is set at 2000 PPM with 4 fans connected
- Over temperature alarm is disabled
- LED and MOS alarms are active for fan alarms and external sensor failure (open)

If your system does not utilize an I2C Bus and the temperature control parameters above do not meet your needs, the Vortex can be configured at the factory for special temperature control parameters. Contact Control Resources’ application engineering for assistance.

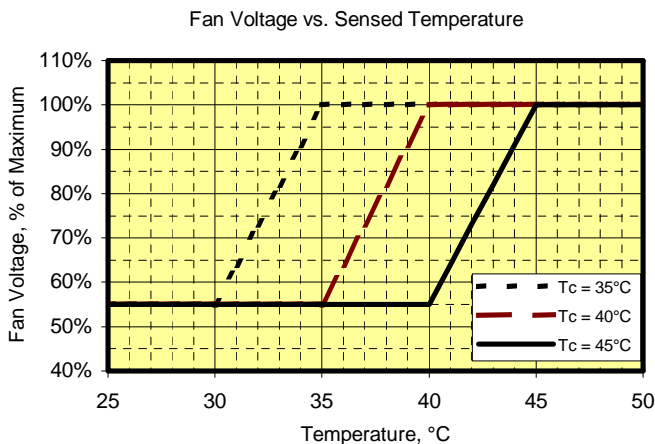

Chart 1.0: Fan voltage vs. sensor temperature examples (5deg slope).

# SmartFan Vortex Datasheet

## Specialized Configurations of the Vortex

The following parameters can be specialized through software modification:

- Relationship between sensed temperature and fan voltage
- Fan speed control based on differential temperature
- Fan speed alarm trigger point
- I2C Bus status register

## Customized Configuration of the Vortex

Contact Control Resources' application engineering with special or custom requirements.

## INSTALLATION

### Mounting

Using the PCB support hardware in hardware pack H122, or equivalent, mount the Vortex on a flat surface using all four mounting holes for maximum support.

## CONNECTIONS

### Connector Pin Assignments:

A description of the function of each connector pin and location is listed in Table 1.0. Depending on the configuration of the Vortex, some headers may not need to be populated.

Header	Label	Description
J1- J4	+	Fan, Positive Terminal
	A	Fan, Tachometer Signal
	-	Fan, Negative Terminal
J5	+	Power Supply, Positive Terminal
	-	Power Supply, Negative Terminal
J7	D	I2C SDA
	C	I2C SCL
	I	I2C Address Id
	S	Speed Override Input
	A	Alarm Output
	G	Signal Ground
	TH	Temperature Sensor
	TH	Temperature Sensor
J8	-	Green LED Cathode
	G	Green LED Anode
	R	Red LED Anode
	-	Red LED Cathode

## Suggested Connecting Hardware

Use CRI Hardware Pack H122 containing the following components shown in Table 2.0.

Header	Mfg. & P/N	H122 Hardware Pack		
		Qty	Description	Mfg. & Part No. <sup>1</sup>
J5	Molex No. 26-60-4020	1	Housing	Molex No. 09-50-8021
		2	Terminal (Tin)	Molex No. 08-50-0106
J1 - J4	Molex No. 22-29-2031	4	Housing	Molex No. 22-01-3037
		12	Terminal (gold)	Molex No. 08-55-0102
J7	Molex No. 22-29-2081	1	Housing	Molex No. 22-01-3087
		8	Terminal (gold)	Molex No. 08-55-0102
J8	Molex No. 22-29-2041	1	Housing	Molex No. 22-01-3047
		4	Terminal (gold)	Molex No. 08-55-0102

<sup>1</sup> Or equivalent

### Input Power Connection to Header J5

Refer to Figure 1.0 for input power wiring. One power supply in the range of 12 VDC +/- 20% should be connected at header J5. The Vortex can supply up to 5.0 Amps (still air) at 12 VDC to the fan load.

### Fan Connection to Headers J1-J4

**Four Fans:** The Vortex distributes power to and monitors the tachometer signals from four three-wire fans. Referring to Figure 1.0, connect the fans to headers J1 through J4. Fan wires are usually color coded with red for +, black or blue for - and white or yellow for tachometer signal. Fan current at each fan header must not exceed 4.0 Amps. Total current required by the fans connected to the Vortex must not exceed 5.0 Amps (still air) at 12 VDC.

**Less than Four Fans:** Through the I2C, each fan header may be disabled. When disabled, the alarm outputs associated with that fan header will always show no alarm.

# SmartFan Vortex Datasheet

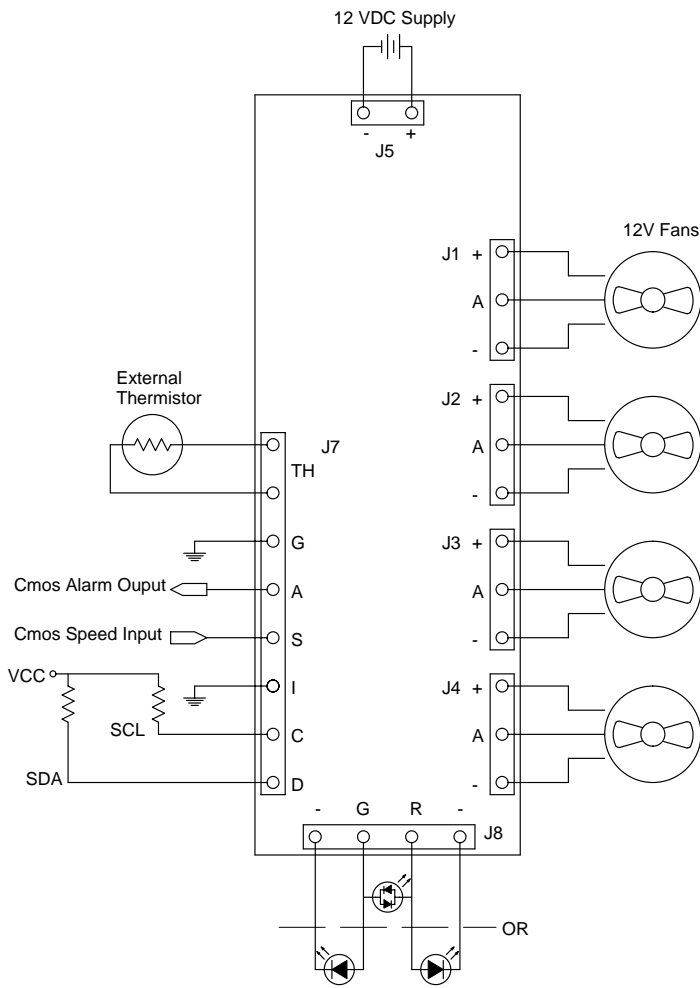

**FIGURE 1.0:** Connection diagram showing input power, fan, alarm, and temperature sensor connections for a Vortex Fan Control.

## Connection of Remote Temperature Sensor to header J7

**Temperature Sensor Connection when I2C Control is used:** When configured to operate with I2C based speed control, temperature readings from both sensors are available. These temperatures do not affect speed or alarms in this control mode.

**Temperature Sensor Control using Sensors:** The Vortex can be configured to operate with either an external sensor or the on-board sensor, which is used to provide temperature based fan speed control and alarming. Referring to Figure 1.0, connect the external sensor if used to header J7. There is no polarity consideration when connecting the sensor. Temperature accuracy and hysteresis is 2°C.

## Connection of I2C Bus to Header J7

**I2C Bus Speed Command Inputs when Temperature Sensor based Fan Control is used:** When configured for temperature sensor based fan control, header J7 will accept I2C commands. If a speed control command is given the Vortex will automatically switch to I2C based speed control mode. Temperature Sensor based fan control configurations support all I2C alarm status registers.

**Internal VCC:** The setting of a jumper at header J6 determines 3.3 or 5.0 VDC bus operation. The SCL (Pin C) and SDA (Pin D) are internally pulled to VCC with 10.0KΩ resistors. The total pull-up must be limited to 3mA and bus capacitance limited to 400 pf per the I2C specification. The Speed input (Pin S) and the ID input (Pin I) are internally pulled to VCC with 10.0KΩ resistors. The Alarm output (Pin A) is a push-pull CMOS output based on the VCC setting with a 562 Ohm limiting resistor.

**GND (Pin G):** Ground reference pin for the I2C Bus.

## Connection of LEDs to Header J8

Header J8 provides local indication of Alarm (R) and Normal (G) status. Referring to Figure 1.0, connect alarm LEDs to header J8. **All alarm circuits on header J8 are non-isolated from input power (J5).** Choose single color LEDs or two leaded, bi-color LEDs with a rated forward voltage ( $V_f$ ) between 1.6 and 2.4 VDC at a forward current ( $I_f$ ) of between 15 and 25 mA. Nominal current applied to the LEDs is 8 mA.

## Connection of Remote Alarm Circuits to Header J7

A signal logic level alarm output is provided on header J7 to provide remote indication of alarm status. Referring to Figure 1.0, connect logic circuits to header J7. **All alarm circuits on header J7 are non-isolated from input power (J5).**

## OPERATION

### Remote Sensor Selection (J7)

When configured to operate with a remote external temperature sensor, choose a compatible SmartFan Sensor shown in the SmartFan Catalog at [www.controlres.com/sensors.htm](http://www.controlres.com/sensors.htm). Control temperature is set through the I2C Bus.

### Board-Mounted Temperature Sensor

In this application, fan voltage is proportional to the temperature at the sensor that is soldered to the Vortex. Control temperature is set through the I2C Bus

# SmartFan Vortex Datasheet

## Fan Tachometer Setting

Since fan tachometer circuits are designed with one, two or even more pulse outputs per revolution, settings are listed in pulses per minute (PPM) rather than revolutions per minute (RPM). Given the fan's speed under load (W) and the number of pulses per revolution (N), use the following formula to select the trigger speed (W<sub>A</sub>):

$$W_A = W \times N \times 0.3$$

For example, a 3300-RPM fan with two pulses per revolution would have a trigger speed of

$$W_A = 3300 \text{ RPM} \times 2 \text{ PPR} \times 0.3 = 1980 \text{ PPM.}$$

Since the 2000 PPM trigger is closest, set tachometer speed to 2000 PPM.

The alarm trigger accuracy is +/- 20%.

The Vortex default factory setting is 2000 PPM.

## On-Board Isolated Power Setting (J6)

The Vortex provides 3.3 or 5.0 VDC power for the I2C Bus interface. Use header J6 to select the power required. Move the shunt to 3.3 if 3.3 VDC power is required. Move the shunt to 5.0 if 5.0 VDC power is required.

## Led Output Status Operation (J8)

Both normally on (green) and normally off (red) LED outputs are provided. Two leaded and three leaded (common Cathode) Bi-colored LEDs can also be used.

## Alarm Logic (J7 – Pin A)

A single Alarm output is provided on J7. The output is set to VCC when there is no alarm and Ground during any alarm condition. The output is current limited by a 600 Ohm drive impedance.

## Fan Voltage in any Alarm Condition

During the presence of any alarm condition, the full supply voltage is applied to the fans.

## Speed Override Input (J7 – Pin S)

A non-isolated input is located at J7 that allows the user to command the fans to full speed when a ground level is applied. If this input is set to VCC or open then the speed is set by its normal operating mode. Refer to Figure 1 for wiring details.

## **I2C BUS PROTOCOL**

The I2C Bus is configured as a slave device that can transmit and receive data. When the Vortex is configured for I2C based speed control, the user can write speed commands to the Vortex and read all alarm status bits. When configured for temperature

based control the user can read all alarm status bits from the Vortex. Writing an I2C speed command changes the control mode from temperature based to I2C based.

## Specifications

- The bus supports seven-bit addressing and only acts as a slave device.
- The address for the fan controller is 0x0C ('0001100') when the ID pin is pulled low. The address for the fan controller is 0x0D ('0001101') when the ID pin is pulled high or floating.
- General call support is not provided.
- The fan controller will stretch the clock further if needed. The I2C master must observe clock stretching.
- The hardware register will support Standard Mode I2C with speeds up to 100 KHz, however, lower clock speeds are recommended for increased noise immunity.
- If temperature control mode is disabled and I2C speed mode is used, then I2C communication must occur within ~2 minutes of the last communication, or there will be an I2C communication timeout error. When an I2C timeout occurs, full supply voltage will be applied to the fans, and fan speed must be reset with a new speed command. Performing any valid I2C operation on a bus will clear the timeout condition and restart the watchdog timer.
- Fan failure based on 2000 minimum PPM of fan in slow (default) mode or 4000 minimum PPM in fast mode. Fan failure is not updated when the output is set to 0 VDC.
- It is possible for noise to cause the I2C hardware to miss an address or data. In this case an Ack will not be generated. The production tester allows 3 errors to occur before marking the board as failing. Also during the EEPROM write cycle the I2C will not generate ACK signals as no more data can be accepted until the write cycle is complete. Typical write cycle is 8ms.

Table 3.0 defines the bits used in the serial bus protocol.

<b>Table 3.0: I2C Bus Definitions</b>	
ACK	Acknowledge
<del>ACK</del>	Not Acknowledge (End of Transmission)
A6 – A0	Address for Fan Controller, bits 6 – 0
D7 – D0	Data TO/FROM Fan Controller, bits 7 – 0
L7 – L0	Data location being accessed, bits 7-0
P	Stop bit
R	Read Bit (1)
S	Start Bit
W	Write Bit (0)

## SmartFan Vortex Datasheet

### Write sequence

S A6 A5 A4 A3 A2 A1 A0 W Ack L7 L6 L5 L4 L3 L2 L1 L0  
Ack D7 D6 D5 D4 D3 D2 D1 D0 Ack P

### Read sequence

S A6 A5 A4 A3 A2 A1 A0 W Ack L7 L6 L5 L4 L3 L2 L1 L0  
Ack P S A6 A5 A4 A3 A2 A1 A0 R Ack D7 D6 D5 D4 D3 D2  
D1 D0 Ack P

### Register Locations: L7-L0 Label (R/W) [initial condition]

Register 0x00 – 0xEF: Generic EEPROM storage (Read/Write)  
[undetermined]

Register 0xF0: Firmware Revision (Read only) [00:current rev]

Register 0xF1: Alarm Status (Read only) [0x00]

D0: Status of fan of 1 (0=no fault, 1= fault)  
D1: Status of fan of 2 (0=no fault, 1= fault)  
D2: Status of fan of 3 (0=no fault, 1= fault)  
D3: Status of fan of 4 (0=no fault, 1= fault)  
D4: Status of speed override (0=normal, 1=12VDC)  
D5: Status of on-board sensor (0=connected, 1= open)  
D6: Status of external sensor (0=connected, 1=open)  
D7: Status of controlling sensor (0=valid, 1=alarm)

Register 0xF2: Temperature (Read only) [1111 1111] on-board sensor

D0-7: Temperature from 0 - 70 in degrees C in 0.5 deg steps  
0xFF = temperature not read yet or open  
(Temperatures above 70 are reported as 254)

Register 0xF3: Temperature (Read only) [1111 1111] external sensor

D0-7: Temperature from 0 - 70 in degrees C in 0.5 deg steps  
0xFF = temperature not read yet or open  
(Temperatures above 70 are reported as 254)

Register 0xF4: Current Target Speed (Read only) [0000 1100]

D0-7: 0x0C = 12 VDC, 0x06 = 6VDC  
(Commanded speed with alarm status override included)  
(In temperature mode this register will read 0x12)

Register 0xF5: Current Speed (Read only) [0000 1100]

D0-7: 0x0C = 12 VDC, 0x06 = 6VDC  
(What the actual current voltage is)  
(In temperature mode this register will read 0x12)

Register 0xF6: Commanded Speed (Read/Write) [1111 1111]

D0-3: 0x0C = 12 VDC, 0x06 = 6VDC  
(0x00 = off, all others = approximate DC voltage applied)  
If set to 0xFF then temperature mode is enabled and I2C speed control disabled

Register 0xF7: Off Temperature (Read/Write) [1111 1111]

D0-7: Temperature from 0 - 70 in degrees C in 0.5 deg steps  
Temperature below which the controller turns off the fan output (0 VDC)  
If set to 0xFF then function disabled

Register 0xF8: Control Temperature (Read/Write) [0101 0000]

D0-7: Temperature from 0 - 70 in degrees C in 0.5 deg steps  
Full speed temperature, only used if Commanded Speed set to 0xFF.

Register 0xF9: Alarm Temperature (Read/Write) [1111 1111]

D0-7: Temperature from 0 - 70 in degrees C in 0.5 deg steps  
Temperature above which the controller alarms  
If set to 0xFF then function disabled

Register 0xFA: Config Register (Read/Write) [0000 1111]

D0-D3: 0=Mask, 1=Active for an Fan (J1-J4)  
D4: Set to 0, may be set to 1 to allow system to indicate a fan controller reset.  
D5: 0=5deg slope, 1=10 deg slope for temperature mode only  
D6: 0=2000PPM tach, 1=4000PPM tach fan alarm speed  
D7: 0=External, 1=On-board sensor selection for temperature mode only

Register 0xFB-0xFF: CRI Test Register (Reserved) [xxxx xxxx]

D0-7: Do not use

Note: If a fan failure occurs the Current Speed will be updated to 12V but the Commanded Speed will remain at its previous value. Once the failure clears the Current Speed will return to the Commanded Speed value. An I2C timeout changes BOTH the Current Speed and Commanded Speed to 12V. The Commanded Speed must be reset after a timeout. During the speed ramp the Current Speed will not match the Commanded Speed until the ramp completes.