

# Adaptable power control

## EPack-3PH compact SCR power controllers Three phase 3 leg control

Designed for fast integration and optimum efficiency



### Product at a glance

OEMs and system integrators need to be able to react quickly to customer needs while maximizing resources. Whether replacing an existing product or designing a new process, the design of the EPack™ power controller has been carefully considered for fast and easy panel installation, commissioning and integration into wider systems, lowering equipment costs, and manufacturing times for you and your customers.

End Users continually need to improve operational efficiency and productivity. EPack power controllers can deliver real savings, significantly reducing your energy costs. Get the best from your operations; quick and easy to install, integrate and commission. A compact size doesn't compromise powerful and versatile features that minimize costs and improve productivity and quality.

> See [EPack™ compact SCR power controllers brochure HA031554](#) to discover how EPack can add value to your business

EPack 3-PH is the ideal solution for the control of all kinds of loads. The control of each phase ensures accurate control, even if the loads are unbalanced). The currents and voltage measures also allow a high level of diagnostics, which can be used for alarm management as well as monitoring (impedance, energy counter, reactive power).

### Key features:

- Nominal load current from 1 amp to 125 amps
- Voltage up to 500V
- Compact DIN Rail and bulkhead mounting
- Configurable via front panel or Eurotherm software (iTools)
- Plug and play Ethernet communications with Zero configuration networking (zeroconf)
- $V^2$ ,  $I^2$  or True power control
- Controls comprehensive range of loads: resistive, infrared, transformer, silicon carbide, ...
- Energy usage measurement
- Advanced load diagnostics
- Integrated dual port Ethernet switch for “daisy chained” communications
- Modbus® TCP, Ethernet/IP or Profinet
- Defend OEM knowledge and IP (OEM Security)

# Specifications

General	
Directive	EMC directive 2014/30/EU Low Voltage Directive 2014/35/EU
Safety specification	EN60947-4-3:2014
EMC emissions specification	EN60947-4-3:2014 - Class A product
EMC immunity specification	EN60947-4-3:2014
Vibration tests	EN60947-1 annex Q category E
Shock tests	EN60947-1 annex Q category E
Approvals	
Europe	CE according to EN60947-4-3:2014 (identical to IEC60947-4-3:2014)
US & Canada	UL60947-4-1 CAN/CSA C22.2 NO.60947-4-1-14 SCCR at 100kA (with Eurotherm recommended fuse)
China	Product not listed in catalogue of products subject to China Compulsory Certification (CCC)
Russian & Baltic countries	EAC approval: CUTR and Pattern approval pending
Protection	CE: IP20 according to EN60529 UL: open type

Condition of use	
Atmosphere	Non-corrosive, non-explosive, non-conductive
Degree of pollution	Degree 2
Storage temperature	-25°C to 70°C (maximum)
Usage temperature	0 to 45°C at 1000m, 0 to 40°C at 2000m
Altitude	1000m maximum at 45°C, 2000m maximum at 40°C
Derating curves	<p>Altitude (meters)</p> <p>Operating temperature (°C)</p>

Mechanical details				
Unit	Height	Width	Depth	Weight
16 to 32A	6.53" (166 mm)	5.51" (140 mm)	7.28" (185 mm)	6.74 lb (3.06 kg)
40 to 63A	6.53" (166 mm)	5.51" (140 mm)	8.66" (220 mm)	7.73 lb (3.51 kg)
80 to 100A	9.37" (238 mm)	6.29" (160 mm)	9.17" (233 mm)	12.85 lb (5.83 kg)
125A	9.37" (238 mm)	9.44" (240 mm)	9.17" (233 mm)	17.50 lb (7.94 kg)

Current rating	Fuse without microswitch		Fuse with microswitch	
	Fuse holder size	Dimensions (H x W x D)	Fuse holder size	Dimensions (H x W x D)
≤25A	10x38	3.41"x2.07"x2.54"	14x51	4.36"x3.13"x3.01"
32A	14x51	4.36"x3.13"x3.01"	14x51	4.36"x3.13"x3.01"
40A	14x51	4.36"x3.13"x3.01"	14x51	4.36"x3.13"x3.01"
50A	22x58	5.03"x4.13"x3.01"	22x58	5.03"x4.13"x3.01"
63A	22x58	5.03"x4.13"x3.01"	22x58	5.03"x4.13"x3.01"
80A	27x60	5.88"x4.72"x3.68"	27x60	5.88"x4.72"x3.68"
100A	27x60	5.88"x4.72"x3.68"	27x60	5.88"x4.72"x3.68"
125A	27x60	5.88"x4.72"x3.68"	27x60	5.88"x4.72"x3.68"

Power	
Nominal current	1 to 125 amps
Nominal voltage	100V to 500V +10%/–15%
Accuracy	+2% of full scale - from 100 to 500V +10%/–15%
Frequency	47Hz to 63Hz
Protection	High speed fuses
Type of loads	
AC51	Resistive or slightly inductive load (cos phi>0.8)
AC-56a	Transformer Primary or MOSI2 (e.g. Molybdenum disilicide) Time temperature dependant loads (e.g.Silicon Carbide)

Control	
Auxiliary power supply	100V to 500V +10%/–15% or 24 ac/dc (±20%)
Control setpoint	Analogue or logic input or digital comms
Analogue input signal	
Voltage	Range: 0-5V, 1-5 V, 0-10V or 2-10V Impedance: 140 k Ohms typical (0-10V signal)
Current	Range: 0-20mA or 4-20mA Input resistance: 100 ohms to allow for three units wired in series to be driven from a single controller's analogue output
Resolution	11 bits
Linearity	±0.1% of Scale
Firing mode	Variable Modulation Burst firing (default 16 cycles), Fix modulation period (default 2 seconds, Logic mode)
Control mode	V <sup>2</sup> control, I <sup>2</sup> control, True Power control, Open loop with feed forward and Trim modes, Threshold limit or by transfer V <sup>2</sup> <-> I <sup>2</sup> or P <-> I <sup>2</sup>
Configurable digital inputs	Input 1: enable by default Input 2: setpoint, alarm acknowledgment, 10V supply, ...
Voltage inputs	Active level (high): 11V<Vin<30V with 6mA<lin<30mA Non-active level (low): -3V<Vin<5V with 2mA<lin<30mA or 5V<lin<11V with lin<2mA PLC compatible inputs, types 1 & 2 according to IEC 61131-2
Contact closure inputs	Source current: 10mA min; 15mA max Open contact (non active) resistance: 800 Ohms to ∞ Closed contact (active) resistance: 0 to 450 Ohms Absolute Maxima ±30V or ±25mA
Alarm Relay	Changeover relay 2A rms - 264V rms normally energised. (250V rms max for UL)  This relay will be de-energised in case of serious alarms: short circuit thyristor, open circuit, fuse blown, missing main, chop off

Communications	
Connection	Dual port Ethernet - RJ45 Integral switch
Protocols	Modbus® TCP, Ethernet/IP, Profinet
Baud rate	10/100 full or half duplex

Display	
Technology	TFT
Size	1.5"
Messages	Messages for configuration, monitoring and diagnostics

## Mechanical details

16A to 32A & 40A to 63A

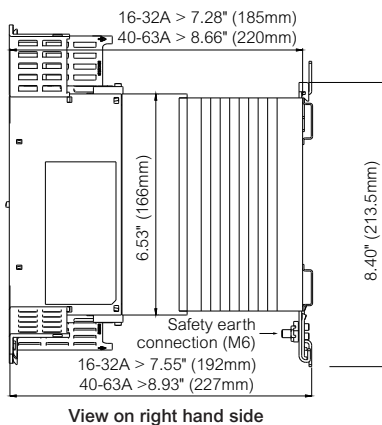
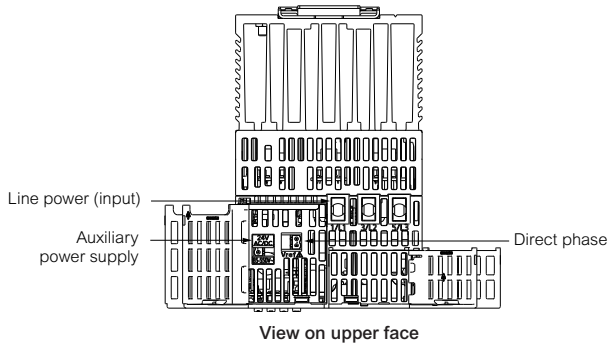
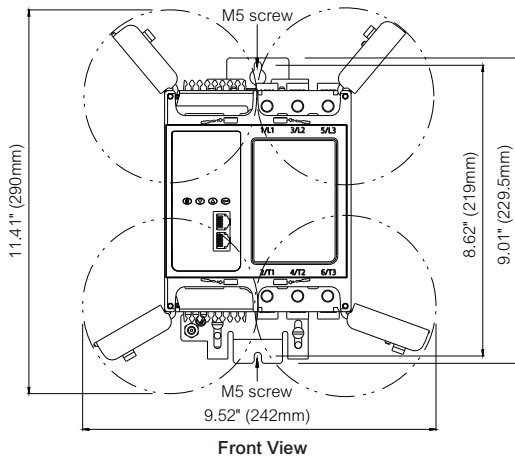
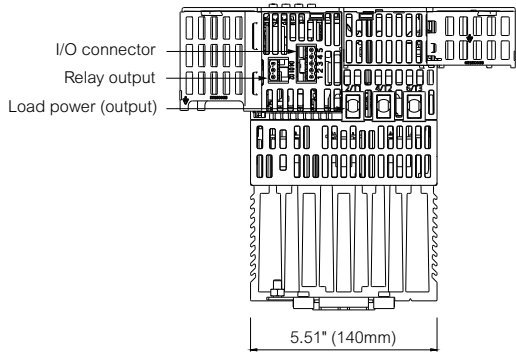

## Connector details (pinout)

I/O Details

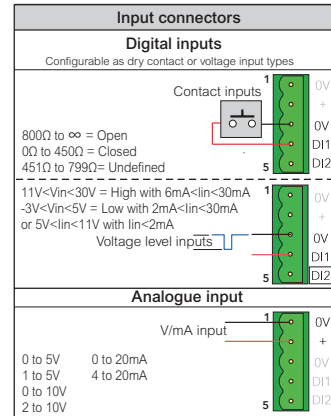

All connectors are keyed to prevent accidental crossing or reversal of connectors.

User configurable input 10.2V, with max. 10mA  
Configurable as +10V output for external potentiometer

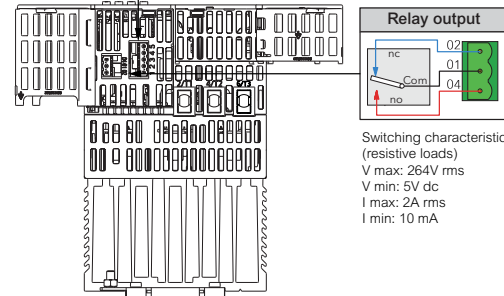

View on lower face

63A unit shown; 32A unit is similar

Power supply details  
16A to 63A

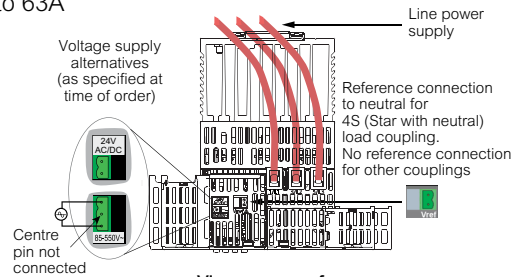

63 unit shown; 32A unit is similar

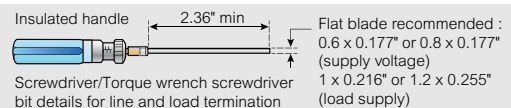
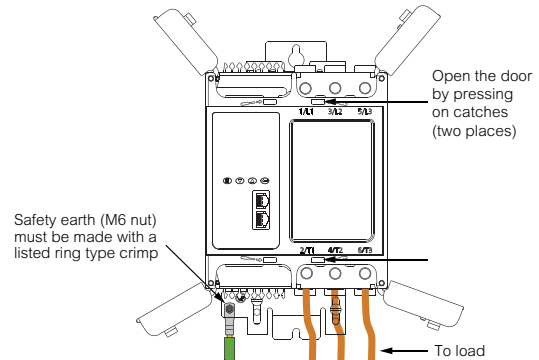

## Mechanical details

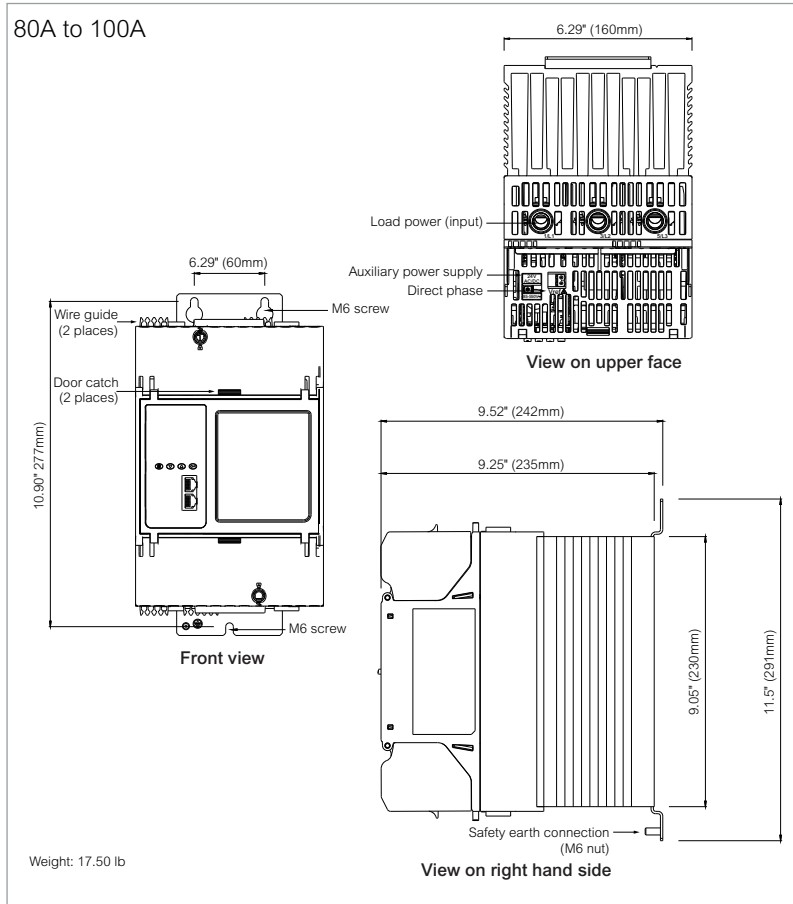

## Connector details (pinout)

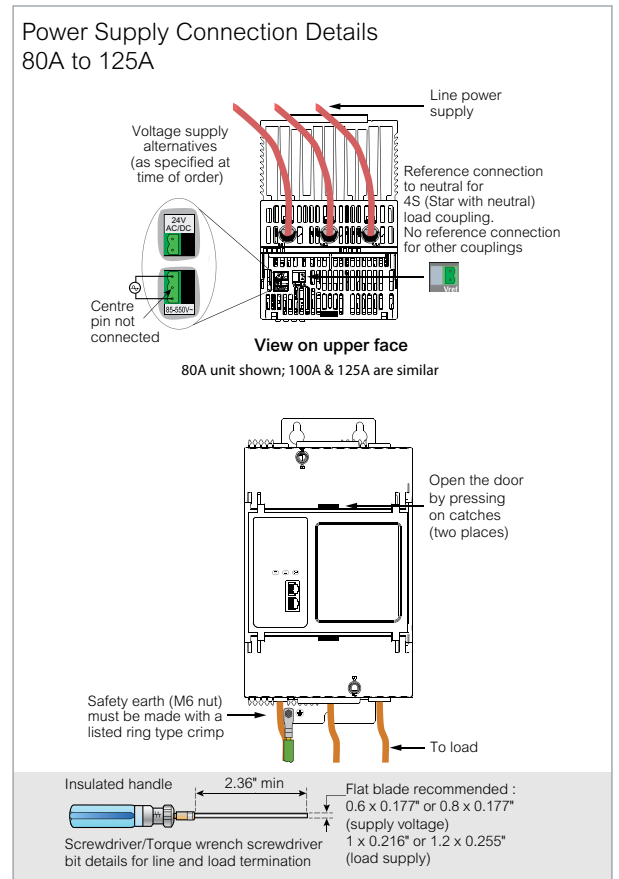
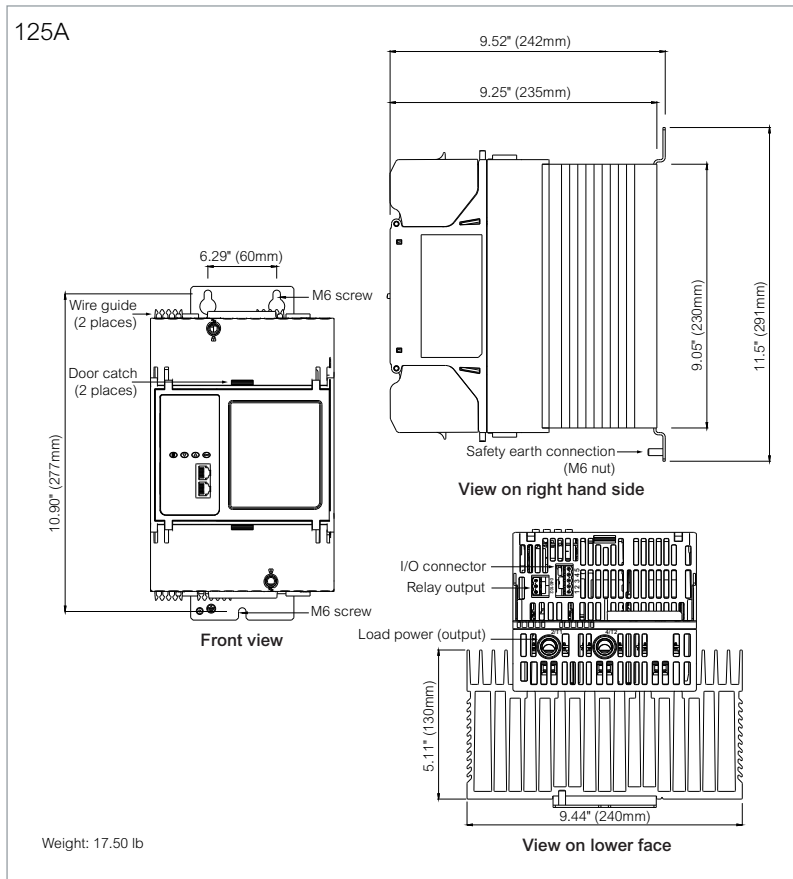
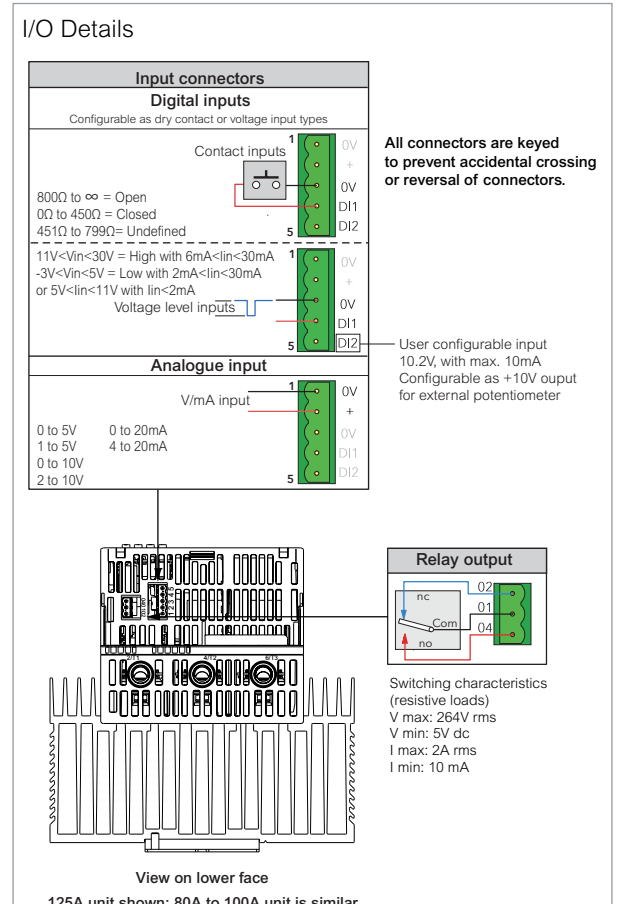

# Order Codes

The EPack power controller is ordered using a short code for hardware and chargeable software options and an optional extended code section configuration of commissioning options.

If the extended code is not used, the software configuration is completed using a quick start procedure or using Eurotherm iTools software.

EPack controllers may be upgraded with additional chargeable options at any time using a software key order code.

## Product coding

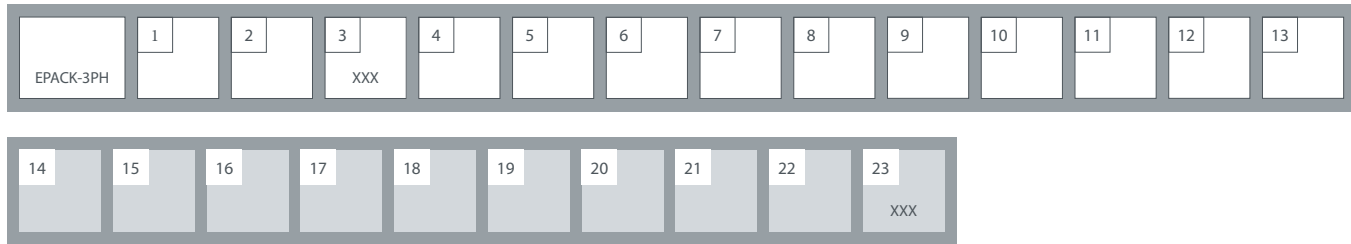

Model	
EPACK-3PH	Power Controller

1 Maximum current	
16A	16 amps
25A	25 amps
32A	32 amps
40A	40 amps
50A	50 amps
63A	63 amps
80A	80 amps
100A	100 amps
125A	125 amps

2 Auxiliary Power Supply	
500V	500V max
24V	24V ac/dc

3 Reserved	
XXX	Reserved

4 Control Option	
V2	V <sup>2</sup> control (standard)
I2	i <sup>2</sup> control
V2CL	V <sup>2</sup> control with current limitation by threshold
PWRCL	Power control with current limit

5 Transfer Option	
XXX	-
TFR	i <sup>2</sup> Transfer

6 Energy Option	
XXX	-
EMS	Energy measurement

7 Comms Option	
TCP	Modbus TCP (standard)
IP	Ethernet/IP
PN	Profinet (call factory)

8 OEM Security	
XXX	None
OEM	OEM Security

9 Warranty	
XXX	Standard Warranty
WL005	5 Year Warranty
USWL3	US Extended Warranty

10 Custom Labelling	
XXX	Standard (Eurotherm)
FXXXX	Special Label

11 Graphical wiring	
XXX	None
GWE	Graphical Wiring Editor

12 Fuse	
XXX	Without
HSP	High Speed fuse without microswitch
HSM	High Speed fuse with microswitch

13 Configuration	
XXXXX	Default
LC	Long code

## Optional configuration

14 Nominal load current	
___ A	1 - Value field 1

15 Nominal line voltage	
100V	100 volts
110V	110 volts
115V	115 volts
120V	120 volts
127V	127 volts
200V	200 volts
208V	208 volts
220V	220 volts
230V	230 volts
240V	240 volts
277V	277 volts
380V	380 volts
400V	400 volts
415V	415 volts
440V	440 volts
460V	460 volts
480V	480 volts
500V	500 volts

16 Load configuration	
3S	Star without neutral
3D	Delta
4S	Star with neutral
6D	Open delta

17 Load type	
XX	Resistive
TR	Transformer primary

18 Heater type	
XX	Resistive
MOSI	Molybdenum disilicide
CSI	Silicon Carbide
SWIR	Short Wave Infra-Red

19 Firing mode	
PA	Phase Angle
IHC	Intelligent Half cycle
BF	Variable Modulation Burst firing (default 16 cycles)
FX	Fix modulation period (default 2 seconds)
LGC	Logic mode

20 Analog Input Function	
XX	None
SP	Setpoint
HR	Setpoint limit
IL	Current limit
TS	Current transfer span

21 Analog input type	
0V	0-10 volts
1V	1-5 volts
2V	2-10 volts
5V	0-5 volts
0A	0-20 mA
4A	4-20mA

22 Digital Input 2 Function	
XX	None
LG	Setpoint for logic mode
AK	Alarm acknowledgement
RS	Remote Setpoint selection
FB	Fuse Blown
SU	10V supply

23 Reserved	
XXX	Reserved

## Software upgrade options

EPACKUPG-3PH	1	2	3	4	5	6	7	8
--------------	---	---	---	---	---	---	---	---

<b>1</b>	<b>Serial number instrument</b>
nnnn	Serial number

<b>2</b>	<b>Current ratings</b>
XXX	No change
16A-25A	Upgrade 16A to 25A
16A-32A	Upgrade 16A to 32A
25A-32A	Upgrade 25A to 32A
40A-50A	Upgrade 40A to 50A
40A-63A	Upgrade 40A to 63A
50A-63A	Upgrade 50A to 63A
80A-100A	Upgrade 80A to 100A

<b>3</b>	<b>Control option</b>
XXX	no change
V2-V2CL	Upgrade V <sup>2</sup> to V <sup>2</sup> CL
V2-I2	Upgrade V <sup>2</sup> to I <sup>2</sup>
V2-PWRCL	Upgrade V <sup>2</sup> to PWRCL
I2-V2CL	Upgrade I <sup>2</sup> to V <sup>2</sup> CL
V2CL-PWRCL	Upgrade V <sup>2</sup> CL to PWRCL
I2-PWRCL	Upgrade I <sup>2</sup> to PWRCL

<b>4</b>	<b>Transfer option</b>
XXX	No change
TFR	I <sup>2</sup> Transfer

<b>5</b>	<b>Energy option</b>
XXX	No change
TFR	Energy measurement

<b>6</b>	<b>Comms option</b>
XXX	No change
IP	Ethernet IP
PN	Profinet (call factory)

<b>7</b>	<b>Graphical wiring</b>
XXX	No change
GWE	Graphical wiring editor

<b>8</b>	<b>OEM security</b>
XXX	No change
OEM	OEM Security