

FEATURES

Triaxis digital gyroscope with digital range scaling
 $\pm 75^\circ/\text{sec}$, $\pm 150^\circ/\text{sec}$, $\pm 300^\circ/\text{sec}$ settings

Tight orthogonal alignment: $<0.05^\circ$

Triaxis digital accelerometer: $\pm 18 g$

Autonomous operation and data collection

No external configuration commands required

Start-up time: 180 ms

Sleep mode recovery time: 4 ms

Factory-calibrated sensitivity, bias, and axial alignment

Calibration temperature range

ADIS16360: $+25^\circ\text{C}$

ADIS16365: -40°C to $+85^\circ\text{C}$

SPI-compatible serial interface

Wide bandwidth: 330 Hz

Embedded temperature sensor

Programmable operation and control

Automatic and manual bias correction controls

Bartlett window FIR filter length, number of taps

Digital I/O: data ready, alarm indicator, general-purpose

Alarms for condition monitoring

Sleep mode for power management

DAC output voltage

Enable external sample clock input: up to 1.2 kHz

Single-command self-test

Single-supply operation: 4.75 V to 5.25 V

2000 g shock survivability

Operating temperature range: -40°C to $+105^\circ\text{C}$

APPLICATIONS

Medical instrumentation

Robotics

Platform control

Navigation

GENERAL DESCRIPTION

The ADIS16360/ADIS16365 *iSensor*® devices are complete inertial systems that include a triaxis gyroscope and triaxis accelerometer. Each sensor in the ADIS16360/ADIS16365 combines industry-leading *iMEMS*® technology with signal conditioning that optimizes dynamic performance. The factory calibration characterizes each sensor for sensitivity, bias, alignment, and linear acceleration (gyro bias). As a result, each sensor has its own dynamic compensation formulas that provide accurate sensor measurements.

The ADIS16360/ADIS16365 provide a simple, cost-effective method for integrating accurate, multi-axis inertial sensing into industrial systems, especially when compared with the complexity and investment associated with discrete designs. All necessary motion testing and calibration are part of the production process at the factory, greatly reducing system integration time. Tight orthogonal alignment simplifies inertial frame alignment in navigation systems. An improved SPI interface and register structure provide faster data collection and configuration control.

The ADIS16360/ADIS16365 use a compatible pinout and the same package as the ADIS1635x family. Therefore, systems that currently use the ADIS1635x family can upgrade their performance with minor firmware adjustments in their processor designs. These compact modules are approximately 23 mm × 23 mm × 23 mm and provide a flexible connector interface that enables multiple mounting orientation options.

FUNCTIONAL BLOCK DIAGRAM

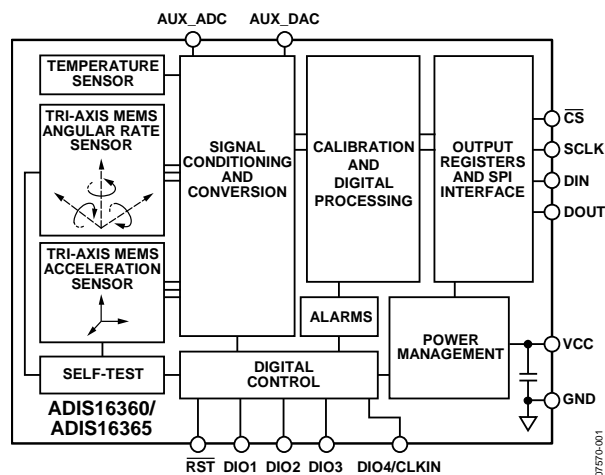

Figure 1.

Rev. B

Information furnished by Analog Devices is believed to be accurate and reliable. However, no responsibility is assumed by Analog Devices for its use, nor for any infringements of patents or other rights of third parties that may result from its use. Specifications subject to change without notice. No license is granted by implication or otherwise under any patent or patent rights of Analog Devices. Trademarks and registered trademarks are the property of their respective owners.

One Technology Way, P.O. Box 9106, Norwood, MA 02062-9106, U.S.A.

Tel: 781.329.4700

Fax: 781.461.3113

www.analog.com

©2009 Analog Devices, Inc. All rights reserved.

TABLE OF CONTENTS

Features	1	Memory Map	10
Applications.....	1	Burst Read Data Collection	11
General Description	1	Output Data Registers	11
Functional Block Diagram	1	Calibration.....	12
Revision History	2	Operational Control.....	12
Specifications.....	3	Input/Output Functions	14
Timing Specifications	5	Diagnostics.....	15
Timing Diagrams.....	5	Product Identification.....	16
Absolute Maximum Ratings.....	6	Applications Information	17
ESD Caution.....	6	Installation/Handling.....	17
Pin Configuration and Function Descriptions.....	7	Gyroscope Bias Optimization.....	17
Typical Performance Characteristics	8	Input ADC Channel.....	17
Theory of Operation	9	Interface Printed Circuit Board (PCB).....	17
Basic Operation	9	Outline Dimensions.....	18
Reading Sensor Data.....	9	Ordering Guide	18
Device Configuration	9		

REVISION HISTORY

12/09—Rev. A to Rev. B

Reorganized Layout.....	Universal
Changes to Features Section.....	1
Changes to Table 1.....	3
Changes to Table 2.....	5
Changes to Table 5.....	7
Changes to Table 7, Device Configuration Section	9
Changes to Table 8.....	10
Changes to Burst Read Data Collection Section, Output Data Registers Section, Table 9	11
Added Table 10, Table 11, Table 12, Table 13, and Table 14; Renumbered Tables Sequentially.....	11
Added Sensor Bandwidth Section and Figure 14; Renumbered Figures Sequentially.....	13
Changes to Digital Filtering Section	13
Changes to General-Purpose I/O Section.....	14
Changes to Table 26.....	15
Changes to Table 29 and Table 31	16
Added Product Identification Section	16
Added Applications Information Section, Figure 15, Figure 16, Figure 17; Renumbered Figures Sequentially.....	17

4/09—Rev. 0 to Rev. A

Changes to Features Section	1
Changes to Scale Factor, Table 1.....	3
Changes to Figure 5 and Figure 6.....	7
Changes to Figure 7 and Figure 8.....	8
Changes to Device Configuration Section.....	9
Changes to Figure 12.....	10
Changes to Operational Control Section	12

1/09—Revision 0: Initial Version

SPECIFICATIONS

$T_A = 25^\circ\text{C}$, $V_{CC} = 5.0\text{ V}$, angular rate = $0^\circ/\text{sec}$, dynamic range = $\pm 300^\circ/\text{sec} \pm 1\text{ g}$, unless otherwise noted.

Table 1.

Parameter	Test Conditions/Comments	Min	Typ	Max	Unit
GYROSCOPES					
Dynamic Range		± 300	± 350		$^\circ/\text{sec}$
Initial Sensitivity	Dynamic range = $\pm 300^\circ/\text{sec}$	0.0495	0.05	0.0505	$^\circ/\text{sec}/\text{LSB}$
	Dynamic range = $\pm 150^\circ/\text{sec}$		0.025		$^\circ/\text{sec}/\text{LSB}$
	Dynamic range = $\pm 75^\circ/\text{sec}$		0.0125		$^\circ/\text{sec}/\text{LSB}$
Sensitivity Temperature Coefficient	ADIS16360, $-40^\circ\text{C} \leq T_A \leq +85^\circ\text{C}$		± 350		ppm/ $^\circ\text{C}$
	ADIS16365, $-40^\circ\text{C} \leq T_A \leq +85^\circ\text{C}$		± 40		ppm/ $^\circ\text{C}$
Misalignment	Reference to z-axis accelerometer		± 0.05		Degrees
	Axis-to-frame (package)		± 0.5		Degrees
Nonlinearity	Best fit straight line		± 0.1		% of FS
Initial Bias Error	$\pm 1\sigma$		± 3		$^\circ/\text{sec}$
In-Run Bias Stability	1 σ , SMPL_PRD = 0x0001		0.007		$^\circ/\text{sec}$
Angular Random Walk	1 σ , SMPL_PRD = 0x0001		2.0		$^\circ/\sqrt{\text{hr}}$
Bias Temperature Coefficient	ADIS16360, $-40^\circ\text{C} \leq T_A \leq +85^\circ\text{C}$		± 0.025		$^\circ/\text{sec}/^\circ\text{C}$
	ADIS16365, $-40^\circ\text{C} \leq T_A \leq +85^\circ\text{C}$		± 0.01		$^\circ/\text{sec}/^\circ\text{C}$
Linear Acceleration Effect on Bias	Any axis, 1 σ (MSC_CTRL[7] = 1)		0.05		$^\circ/\text{sec}/\text{g}$
Bias Voltage Sensitivity	$V_{CC} = 4.75\text{ V}$ to 5.25 V		± 0.3		$^\circ/\text{sec}/\text{V}$
Output Noise	$\pm 300^\circ/\text{sec}$ range, no filtering		0.8		$^\circ/\text{sec rms}$
Rate Noise Density	$f = 25\text{ Hz}$, $\pm 300^\circ/\text{sec}$ range, no filtering		0.044		$^\circ/\text{sec}/\sqrt{\text{Hz rms}}$
3 dB Bandwidth			330		Hz
Sensor Resonant Frequency			14.5		kHz
Self-Test Change in Output Response	$\pm 300^\circ/\text{sec}$ range setting	± 696	± 1400	± 2449	LSB
ACCELEROMETERS					
Dynamic Range	Each axis	± 18			g
Initial Sensitivity		3.285	3.33	3.38	mg/LSB
Sensitivity Temperature Coefficient	ADIS16360, $-40^\circ\text{C} \leq T_A \leq +85^\circ\text{C}$		± 120		ppm/ $^\circ\text{C}$
	ADIS16365, $-40^\circ\text{C} \leq T_A \leq +85^\circ\text{C}$		± 50		ppm/ $^\circ\text{C}$
Misalignment	Axis-to-axis, $\Delta = 90^\circ$ ideal		0.2		Degrees
	Axis-to-frame (package)		± 0.5		Degrees
Nonlinearity	Best fit straight line		0.1		% of FS
Initial Bias Error	$\pm 1\sigma$		± 50		mg
In-Run Bias Stability	1 σ		0.2		mg
Velocity Random Walk	1 σ		0.2		m/sec/ $\sqrt{\text{hr}}$
Bias Temperature Coefficient	ADIS16360, $-40^\circ\text{C} \leq T_A \leq +85^\circ\text{C}$		± 4		mg/ $^\circ\text{C}$
	ADIS16365, $-40^\circ\text{C} \leq T_A \leq +85^\circ\text{C}$		± 0.3		mg/ $^\circ\text{C}$
Bias Voltage Sensitivity	$V_{CC} = 4.75\text{ V}$ to 5.25 V		2.5		mg/V
Output Noise	No filtering		9		mg rms
Noise Density	No filtering		0.5		mg/ $\sqrt{\text{Hz rms}}$
3 dB Bandwidth			330		Hz
Sensor Resonant Frequency			5.5		kHz
Self-Test Change in Output Response	X-axis and y-axis	59		151	LSB
TEMPERATURE SENSOR					
Scale Factor	Output = 0x0000 at 25°C ($\pm 5^\circ\text{C}$)		0.136		$^\circ\text{C}/\text{LSB}$
ADC INPUT					
Resolution			12		Bits
Integral Nonlinearity			± 2		LSB
Differential Nonlinearity			± 1		LSB
Offset Error			± 4		LSB

ADIS16360/ADIS16365

Parameter	Test Conditions/Comments	Min	Typ	Max	Unit
Gain Error			±2		LSB
Input Range		0		3.3	V
Input Capacitance	During acquisition		20		pF
DAC OUTPUT	5 kΩ/100 pF to GND				
Resolution			12		Bits
Relative Accuracy	101 LSB ≤ input code ≤ 4095 LSB		±4		LSB
Differential Nonlinearity			±1		LSB
Offset Error			±5		mV
Gain Error			±0.5		%
Output Range		0		3.3	V
Output Impedance			2		Ω
Output Settling Time			10		μs
LOGIC INPUTS ¹					
Input High Voltage, V _{IH}		2.0			V
Input Low Voltage, V _{IL}				0.8	V
$\overline{\text{CS}}$ Wake-Up Pulse Width	$\overline{\text{CS}}$ signal to wake up from sleep mode			0.55	V
Logic 1 Input Current, I _{IH}	V _{IH} = 3.3 V		±0.2	±10	μA
Logic 0 Input Current, I _{IL}	V _{IL} = 0 V				
All Pins Except $\overline{\text{RST}}$			40	60	μA
$\overline{\text{RST}}$ Pin			1		mA
Input Capacitance, C _{IN}			10		pF
DIGITAL OUTPUTS ¹					
Output High Voltage, V _{OH}	I _{SOURCE} = 1.6 mA	2.4			V
Output Low Voltage, V _{OL}	I _{SINK} = 1.6 mA			0.4	V
FLASH MEMORY					
Data Retention ³	Endurance ² T _J = 85°C	10,000 20			Cycles Years
FUNCTIONAL TIMES ⁴	Time until data is available				
Power-On Start-Up Time	Normal mode, SMPL_PRD ≤ 0x09 Low power mode, SMPL_PRD ≥ 0x0A		180 250		ms ms
Reset Recovery Time	Normal mode, SMPL_PRD ≤ 0x09 Low power mode, SMPL_PRD ≥ 0x0A		60 130		ms ms
Sleep Mode Recovery Time	Normal mode, SMPL_PRD ≤ 0x09 Low power mode, SMPL_PRD ≥ 0x0A		4 9		ms ms
Flash Memory Test Time	Normal mode, SMPL_PRD ≤ 0x09 Low power mode, SMPL_PRD ≥ 0x0A		17 90		ms ms
Automatic Self-Test Time	SMPL_PRD = 0x0001		12		ms
CONVERSION RATE	SMPL_PRD = 0x0001 to 0x00FF	0.413		819.2	SPS
Clock Accuracy				±3	%
Sync Input Clock		0.8 ⁵		1.2	kHz
POWER SUPPLY					
Power Supply Current	Operating voltage range, VCC Low power mode Normal mode Sleep mode	4.75	5.0 24 49 500	5.25	V mA mA μA

¹ The digital I/O signals are driven by an internal 3.3 V supply, and the inputs are 5 V tolerant.

² Endurance is qualified as per JEDEC Standard 22, Method A117, and measured at -40°C, +25°C, +85°C, and +125°C.

³ The data retention lifetime equivalent is at a junction temperature (T_J) of 85°C as per JEDEC Standard 22, Method A117. Data retention lifetime decreases with junction temperature.

⁴ These times do not include thermal settling and internal filter response times (330 Hz bandwidth), which may affect overall accuracy.

⁵ The sync input clock functions below the specified minimum value, at reduced performance levels.

TIMING SPECIFICATIONS

T_A = 25°C, VCC = 5 V, unless otherwise noted.

Table 2.

Parameter	Description	Normal Mode (SMPL_PRD ≤ 0x09)			Low Power Mode (SMPL_PRD ≥ 0x0A)			Burst Read			Unit
		Min ¹	Typ	Max	Min ¹	Typ	Max	Min ¹	Typ	Max	
f _{SCLK}	Serial clock	0.01		2.0	0.01		0.3	0.01		1.0	MHz
t _{STALL}	Stall period between data	9			75			1/f _{SCLK}			μs
t _{READRATE}	Read rate	40			100						μs
t _{CS}	Chip select to clock edge	48.8			48.8			48.8			ns
t _{DAV}	DOUT valid after SCLK edge			100			100			100	ns
t _{DSU}	DIN setup time before SCLK rising edge	24.4			24.4			24.4			ns
t _{DHD}	DIN hold time after SCLK rising edge	48.8			48.8			48.8			ns
t _{SCLKR} , t _{SCLKF}	SCLK rise/fall times		5	12.5		5	12.5		5	12.5	ns
t _{DR} , t _{DF}	DOUT rise/fall times		5	12.5		5	12.5		5	12.5	ns
t _{SFS}	\overline{CS} high after SCLK edge	5			5			5			ns
t ₁	Input sync positive pulse width	5						5			μs
t _x	Input sync low time	100						100			μs
t ₂	Input sync to data ready output		600						600		μs
t ₃	Input sync period	833						833			μs

¹ Guaranteed by design and characterization, but not tested in production.

TIMING DIAGRAMS

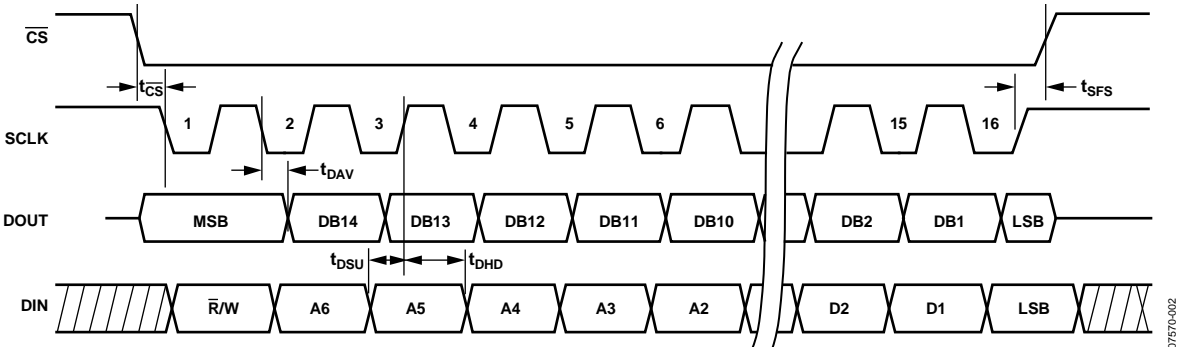

Figure 2. SPI Timing and Sequence

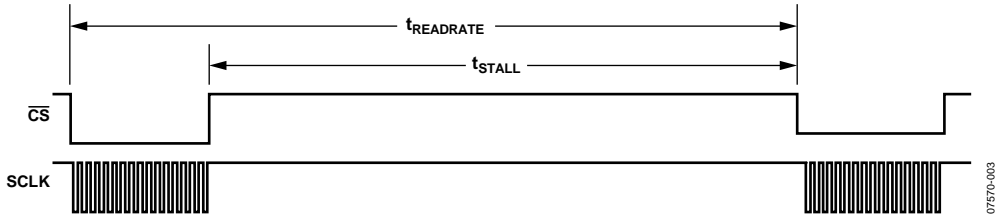

Figure 3. Stall Time and Data Rate

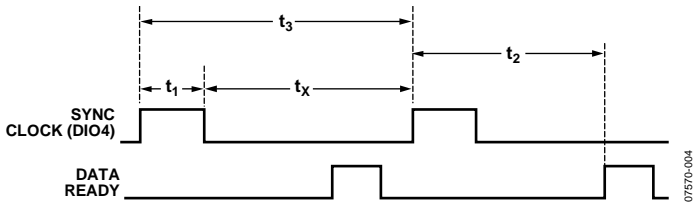

Figure 4. Input Clock Timing Diagram

ADIS16360/ADIS16365

ABSOLUTE MAXIMUM RATINGS

Table 3.

Parameter	Rating
Acceleration	
Any Axis, Unpowered	2000 g
Any Axis, Powered	2000 g
VCC to GND	-0.3 V to +6.0 V
Digital Input Voltage to GND	-0.3 V to +5.3 V
Digital Output Voltage to GND	-0.3 V to VCC + 0.3 V
Analog Input to GND	-0.3 V to +3.6 V
Operating Temperature Range	-40°C to +105°C
Storage Temperature Range	-65°C to +125°C ^{1,2}

¹ Extended exposure to temperatures outside the specified temperature range of -40°C to +105°C can adversely affect the accuracy of the factory calibration. For best accuracy, store the parts within the specified operating range of -40°C to +105°C.

² Although the device is capable of withstanding short-term exposure to 150°C, long-term exposure threatens internal mechanical integrity.

Stresses above those listed under Absolute Maximum Ratings may cause permanent damage to the device. This is a stress rating only; functional operation of the device at these or any other conditions above those indicated in the operational section of this specification is not implied. Exposure to absolute maximum rating conditions for extended periods may affect device reliability.

Table 4. Package Characteristics

Package Type	θ_{JA}	θ_{JC}	Device Weight
24-Lead Module (ML-24-2)	39.8°C/W	14.2°C/W	16 grams

ESD CAUTION



ESD (electrostatic discharge) sensitive device. Charged devices and circuit boards can discharge without detection. Although this product features patented or proprietary protection circuitry, damage may occur on devices subjected to high energy ESD. Therefore, proper ESD precautions should be taken to avoid performance degradation or loss of functionality.

PIN CONFIGURATION AND FUNCTION DESCRIPTIONS

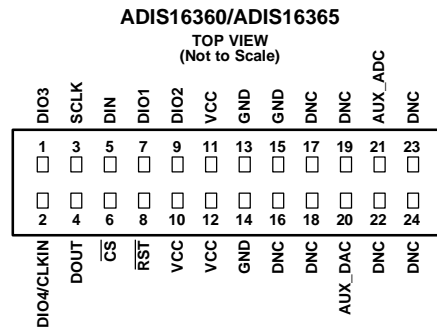

- NOTES**
1. THIS REPRESENTATION DISPLAYS THE TOP VIEW PINOUT FOR THE MATING SOCKET CONNECTOR.
 2. THE ACTUAL CONNECTOR PINS ARE NOT VISIBLE FROM THE TOP VIEW.
 3. MATING CONNECTOR: SAMTEC CLM-112-02 OR EQUIVALENT.
 4. DNC = DO NOT CONNECT.

Figure 5. Pin Configuration

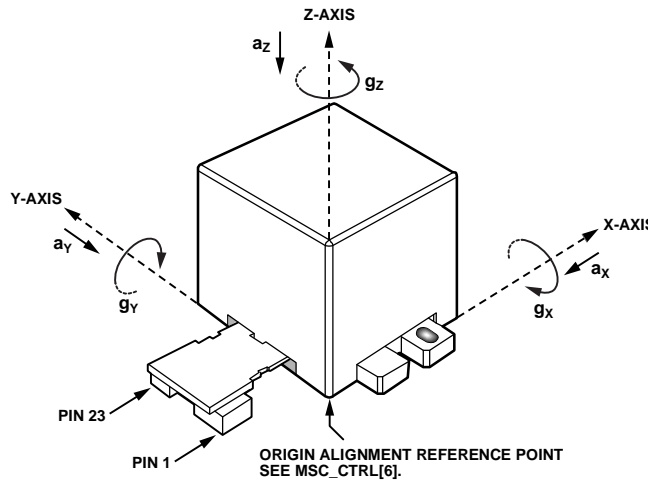

- NOTES**
1. ACCELERATION (a_x , a_y , a_z) AND ROTATIONAL (g_x , g_y , g_z) ARROWS INDICATE THE DIRECTION OF MOTION THAT PRODUCES A POSITIVE OUTPUT.

Figure 6. Axial Orientation

Table 5. Pin Function Descriptions

Pin No.	Mnemonic	Type ¹	Description
1	DIO3	I/O	Configurable Digital Input/Output.
2	DIO4/CLKIN	I/O	Configurable Digital Input/Output or Sync Clock Input.
3	SCLK	I	SPI Serial Clock.
4	DOUT	O	SPI Data Output. Clocks output on SCLK falling edge.
5	DIN	I	SPI Data Input. Clocks input on SCLK rising edge.
6	CS	I	SPI Chip Select.
7, 9	DIO1, DIO2	I/O	Configurable Digital Input/Output.
8	RST	I	Reset.
10, 11, 12	VCC	S	Power Supply.
13, 14, 15	GND	S	Power Ground.
16, 17, 18, 19, 22, 23, 24	DNC	N/A	Do Not Connect.
20	AUX_DAC	O	Auxiliary, 12-Bit DAC Output.
21	AUX_ADC	I	Auxiliary, 12-Bit ADC Input.

¹ I/O is input/output, I is input, O is output, S is supply, N/A is not applicable.

TYPICAL PERFORMANCE CHARACTERISTICS

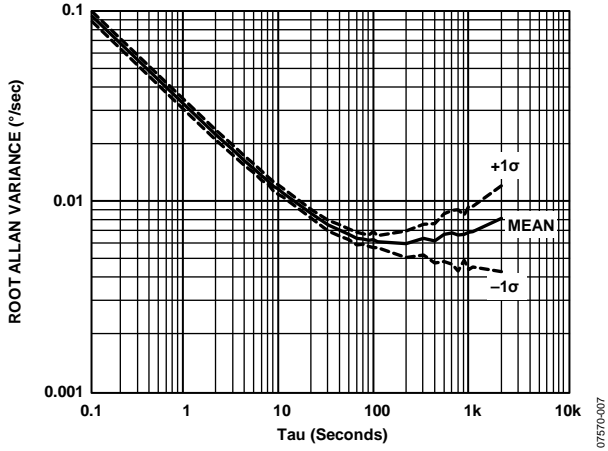

Figure 7. Gyroscope Allan Variance

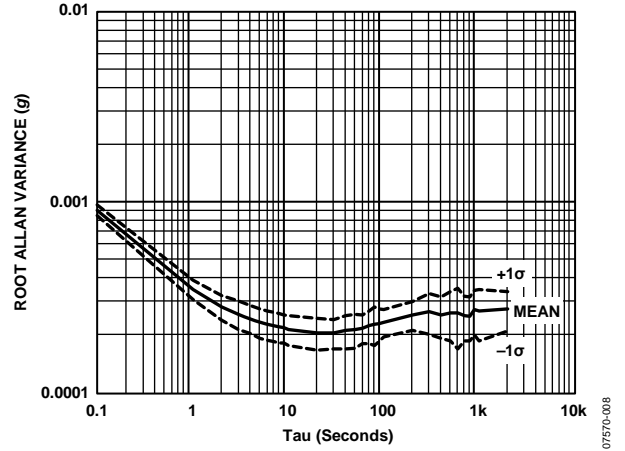

Figure 8. Accelerometer Allan Variance

THEORY OF OPERATION

BASIC OPERATION

The ADIS16360/ADIS16365 are autonomous sensor systems that start up after they have a valid power supply voltage and begin producing inertial measurement data at the factory default sample rate setting of 819.2 SPS. After each sample cycle, the sensor data is loaded into the output registers, and DIO1 pulses high, which provides a new data ready control signal for driving system-level interrupt service routines. In a typical system, a master processor accesses the output data registers through the SPI interface, using the connection diagram shown in Figure 9. Table 6 provides a generic functional description for each pin on the master processor. Table 7 describes the typical master processor settings that are normally found in a configuration register and used for communicating with the ADIS16360/ADIS16365.

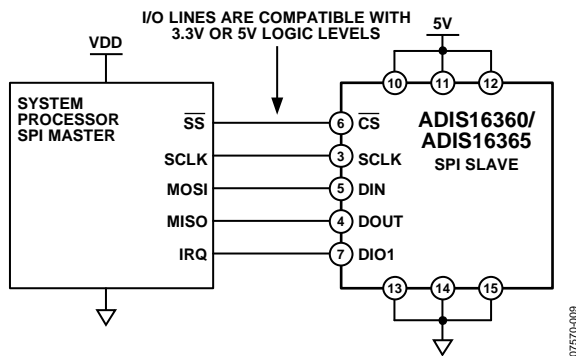

Figure 9. Electrical Connection Diagram

Table 6. Generic Master Processor Pin Names and Functions

Pin Name	Function
SS	Slave select
IRQ	Interrupt request
MOSI	Master output, slave input
MISO	Master input, slave output
SCLK	Serial clock

Table 7. Generic Master Processor SPI Settings

Processor Setting	Description
Master	The ADIS16360/ADIS16365 operate as slaves
SCLK Rate ≤ 2 MHz ¹	Normal mode, SMPL_PRD[7:0] $\leq 0x09$
SPI Mode 3	CPOL = 1 (polarity), CPHA = 1 (phase)
MSB First Mode	Bit sequence
16-Bit Mode	Shift register/data length

¹ For burst read, SCLK rate ≤ 1 MHz. For low power mode, SCLK rate ≤ 300 kHz.

The user registers provide addressing for all input/output operations on the SPI interface. Each 16-bit register has two 7-bit addresses: one for its upper byte and one for its lower byte. Table 8 lists the lower byte address for each register, and Figure 10 shows the generic bit assignments.

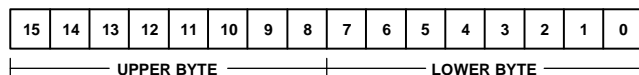

Figure 10. Generic Register Bit Assignments

READING SENSOR DATA

Although the ADIS16360/ADIS16365 produce data independently, they operate as SPI slave devices that communicate with system (master) processors using the 16-bit segments displayed in Figure 11. Individual register reads require two of these 16-bit sequences. The first 16-bit sequence contains the read command bit ($\bar{R}/W = 0$) and the target register address (A6 to A0); the last eight bits are “don't care” bits when requesting a read. The second 16-bit sequence transmits the register contents (D15 to D0) on the DOUT line. For example, if $DIN = 0x0A00$, the contents of XACCL_OUT are shifted out on the DOUT line during the next 16-bit sequence.

The SPI operates in full-duplex mode, which means that the master processor can read the output data from DOUT while using the same SCLK pulses to transmit the next target address on DIN.

DEVICE CONFIGURATION

The user register memory map (see Table 8) identifies configuration registers with either a W or R/W. Configuration commands also use the bit sequence shown in Figure 11. If the MSB = 1, the last eight bits (DC7 to DC0) in the DIN sequence are loaded into the memory address associated with the address bits (A6 to A0). For example, if $DIN = 0xA11F$, $0x1F$ is loaded into Address $0x21$ (XACCL_OFF, upper byte) at the conclusion of the data frame.

The master processor initiates the backup function by setting $GLOB_CMD[3] = 1$ ($DIN = 0xBE04$). This command copies the user registers into their assigned flash memory locations and requires the power supply to stay within its normal operating range for the entire 50 ms process. The FLASH_CNT register provides a running count of these events for monitoring the long-term reliability of the flash memory.

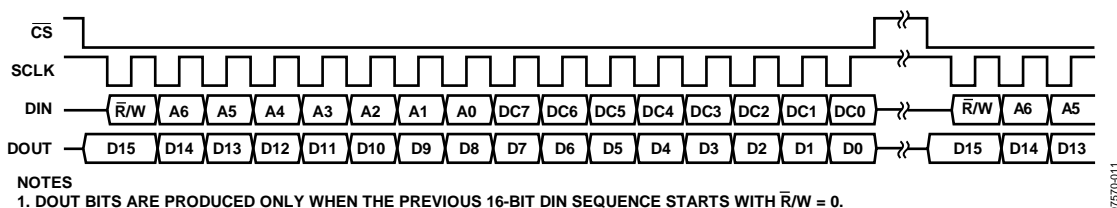

Figure 11. SPI Communication Bit Sequence

ADIS16360/ADIS16365

MEMORY MAP

Table 8. User Register Memory Map

Name	R/W	Flash Backup	Address ¹	Default	Register Description	Bit Function
FLASH_CNT	R	Yes	0x00	N/A	Flash memory write count	N/A
SUPPLY_OUT	R	No	0x02	N/A	Power supply measurement	See Table 9
XGYRO_OUT	R	No	0x04	N/A	X-axis gyroscope output	See Table 9
YGYRO_OUT	R	No	0x06	N/A	Y-axis gyroscope output	See Table 9
ZGYRO_OUT	R	No	0x08	N/A	Z-axis gyroscope output	See Table 9
XACCL_OUT	R	No	0x0A	N/A	X-axis accelerometer output	See Table 9
YACCL_OUT	R	No	0x0C	N/A	Y-axis accelerometer output	See Table 9
ZACCL_OUT	R	No	0x0E	N/A	Z-axis accelerometer output	See Table 9
XTEMP_OUT	R	No	0x10	N/A	X-axis gyroscope temperature measurement	See Table 9
YTEMP_OUT	R	No	0x12	N/A	Y-axis gyroscope temperature measurement	See Table 9
ZTEMP_OUT	R	No	0x14	N/A	Z-axis gyroscope temperature measurement	See Table 9
AUX_ADC	R	No	0x16	N/A	Auxiliary ADC output	See Table 9
Reserved	N/A	N/A	0x18	N/A	Reserved	N/A
XGYRO_OFF	R/W	Yes	0x1A	0x0000	X-axis gyroscope bias offset factor	See Table 15
YGYRO_OFF	R/W	Yes	0x1C	0x0000	Y-axis gyroscope bias offset factor	See Table 15
ZGYRO_OFF	R/W	Yes	0x1E	0x0000	Z-axis gyroscope bias offset factor	See Table 15
XACCL_OFF	R/W	Yes	0x20	0x0000	X-axis acceleration bias offset factor	See Table 16
YACCL_OFF	R/W	Yes	0x22	0x0000	Y-axis acceleration bias offset factor	See Table 16
ZACCL_OFF	R/W	Yes	0x24	0x0000	Z-axis acceleration bias offset factor	See Table 16
ALM_MAG1	R/W	Yes	0x26	0x0000	Alarm 1 amplitude threshold	See Table 27
ALM_MAG2	R/W	Yes	0x28	0x0000	Alarm 2 amplitude threshold	See Table 27
ALM_SMPL1	R/W	Yes	0x2A	0x0000	Alarm 1 sample size	See Table 28
ALM_SMPL2	R/W	Yes	0x2C	0x0000	Alarm 2 sample size	See Table 28
ALM_CTRL	R/W	Yes	0x2E	0x0000	Alarm control	See Table 29
AUX_DAC	R/W	No	0x30	0x0000	Auxiliary DAC data	See Table 23
GPIO_CTRL	R/W	No	0x32	0x0000	Auxiliary digital input/output control	See Table 21
MSC_CTRL	R/W	Yes	0x34	0x0006	Miscellaneous control: data ready, self-test	See Table 22
SMPL_PRD	R/W	Yes	0x36	0x0001	Internal sample period (rate) control	See Table 18
SENS_AVG	R/W	Yes	0x38	0x0402	Dynamic range and digital filter control	See Table 20
SLP_CNT	W	No	0x3A	0x0000	Sleep mode control	See Table 19
DIAG_STAT	R	No	0x3C	0x0000	System status	See Table 26
GLOB_CMD	W	No	0x3E	0x0000	System command	See Table 17
Reserved	N/A	N/A	0x40 to 0x51	N/A	Reserved	N/A
LOT_ID1	R	Yes	0x52	N/A	Lot Identification Code 1	See Table 32
LOT_ID2	R	Yes	0x54	N/A	Lot Identification Code 2	See Table 32
SERIAL_NUM	R	Yes	0x56	N/A	Serial number	See Table 32
PROD_ID	R	Yes	0x58	0x3FE8	Product identification, ADIS16360	See Table 32
PROD_ID	R	Yes	0x58	0x3FED	Product identification, ADIS16365	See Table 32

¹ Each register contains two bytes. The address of the lower byte is displayed. The address of the upper byte is equal to the address of the lower byte plus 1.

BURST READ DATA COLLECTION

Burst read data collection is a process-efficient method for collecting data from the ADIS16360/ADIS16365. In burst read, all output registers are clocked out on DOUT, 16 bits at a time, in sequential data cycles (each separated by one SCLK period). To start a burst read sequence, set DIN = 0x3E00. The contents of each output register are then shifted out on DOUT, starting with SUPPLY_OUT and ending with AUX_ADC (see Figure 13). The addressing sequence shown in Table 8 determines the order of the outputs in burst read.

OUTPUT DATA REGISTERS

Each output data register uses the format in Figure 12 and Table 9. Figure 6 shows the positive direction for each inertial sensor. The ND bit is equal to 1 when the register contains unread data. The EA bit is high when any error/alarm flag in the DIAG_STAT register is equal to 1.

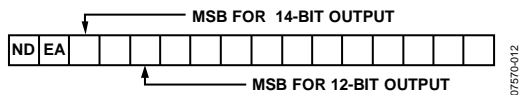

Figure 12. Output Register Bit Assignments

Table 9. Output Data Register Formats

Register	Bits	Scale	Reference
SUPPLY_OUT	12	2.418 mV	See Table 10
XGYRO_OUT ¹	14	0.05°/sec	See Table 11
YGYRO_OUT ¹	14	0.05°/sec	See Table 11
ZGYRO_OUT ¹	14	0.05°/sec	See Table 11
XACCL_OUT	14	3.333 mg	See Table 12
YACCL_OUT	14	3.333 mg	See Table 12
ZACCL_OUT	14	3.333 mg	See Table 12
XTEMP_OUT ²	12	0.136°C	See Table 13
YTEMP_OUT ²	12	0.136°C	See Table 13
ZTEMP_OUT ²	12	0.136°C	See Table 13
AUX_ADC	12	805.8 μV	See Table 14

¹ Assumes that the scaling is set to ±300°/sec. This factor scales with the range.

² 0x0000 = 25°C (±5°C).

Table 10. Power Supply, Offset Binary Format

Supply Voltage	Decimal	Hex	Binary
5.25 V	2171 LSB	0x87B	XXXX 1000 0111 1011
5.002418 V	2069 LSB	0x815	XXXX 1000 0001 0101
5 V	2068 LSB	0x814	XXXX 1000 0001 0100
4.997582 V	2067 LSB	0x813	XXXX 1000 0001 0011
4.75 V	1964 LSB	0x7AC	XXXX 0111 1010 1100

Table 11. Rotation Rate, Twos Complement Format

Rotation Rate	Decimal	Hex	Binary
+300°/sec	+6000 LSB	0x1770	XX01 0111 0111 0000
+0.1°/sec	+2 LSB	0x0002	XX00 0000 0000 0010
+0.05°/sec	+1 LSB	0x0001	XX00 0000 0000 0001
0°/sec	0 LSB	0x0000	XX00 0000 0000 0000
-0.05°/sec	-1 LSB	0x3FFF	XX11 1111 1111 1111
-0.1°/sec	-2 LSB	0x3FFE	XX11 1111 1111 1110
-300°/sec	-6000 LSB	0x2890	XX10 1000 1001 0000

Table 12. Acceleration, Twos Complement Format

Acceleration	Decimal	Hex	Binary
+18 g	+5401 LSB	0x1519	XX01 0101 0001 1001
+6.667 mg	+2 LSB	0x0002	XX00 0000 0000 0010
+3.333 mg	+1 LSB	0x0001	XX00 0000 0000 0001
0 g	0 LSB	0x0000	XX00 0000 0000 0000
-3.333 mg	-1 LSB	0x3FFF	XX11 1111 1111 1111
-6.667 mg	-2 LSB	0x3FFE	XX11 1111 1111 1110
-18 g	-5401 LSB	0x2AE7	XX10 1010 1110 0111

Table 13. Temperature, Twos Complement Format

Temperature	Decimal	Hex	Binary
+105°C	+588 LSB	0x24C	XXXX 0010 0100 1100
+85°C	+441 LSB	0x1B9	XXXX 0001 1011 1001
+25.272°C	+2 LSB	0x002	XXXX 0000 0000 0010
+25.136°C	+1 LSB	0x001	XXXX 0000 0000 0001
+25°C	0 LSB	0x0000	XXXX 0000 0000 0000
+24.864°C	-1 LSB	0xFFF	XXXX 1111 1111 1111
+24.728°C	-2 LSB	0xFFE	XXXX 1111 1111 1110
-40°C	-478 LSB	0xE22	XXXX 1110 0010 0010

Table 14. Analog Input, Offset Binary Format

Input Voltage	Decimal	Hex	Binary
3.3 V	4095 LSB	0xFFFF	XXXX 1111 1111 1111
1 V	1241 LSB	0x4D9	XXXX 0100 1101 1001
1.6116 mV	2 LSB	0x002	XXXX 0000 0000 0010
805.8 μV	1 LSB	0x001	XXXX 0000 0000 0001
0 V	0 LSB	0x000	XXXX 0000 0000 0000

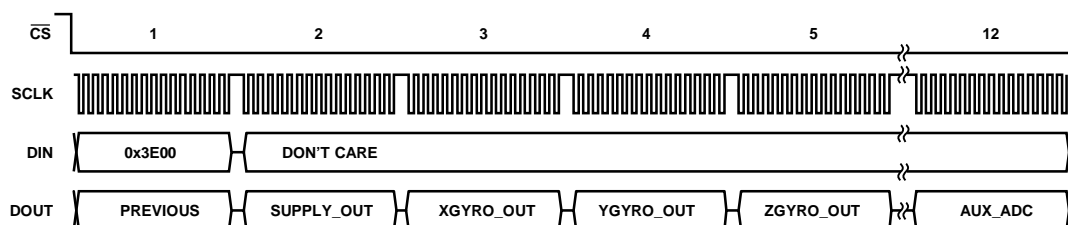

NOTES

1. THE DOUT LINE HAS BEEN SIMPLIFIED FOR SPACE CONSTRAINTS BUT, IDEALLY, SHOULD INCLUDE ALL REGISTERS FROM SUPPLY_OUT THROUGH AUX_ADC.

Figure 13. Burst Read Sequence

ADIS16360/ADIS16365

CALIBRATION

Manual Bias Calibration

The bias offset registers in Table 15 and Table 16 provide a manual adjustment function for the output of each sensor. For example, if XGYRO_OFF = 0x1FF6 (DIN = 0x9B1F, 0x9AF6), the XGYRO_OUT offset shifts by -10 LSBs, or -0.125°/sec.

Table 15. XGYRO_OFF, YGYRO_OFF, ZGYRO_OFF

Bit Descriptions

Bits	Description (Default = 0x0000)
[15:13]	Not used.
[12:0]	Data bits. Twos complement, 0.0125°/sec per LSB. Typical adjustment range = ±50°/sec.

Table 16. XACCL_OFF, YACCL_OFF, ZACCL_OFF

Bit Descriptions

Bits	Description (Default = 0x0000)
[15:12]	Not used.
[11:0]	Data bits. Twos complement, 3.333 mg/LSB. Typical adjustment range = ±6.7 g.

Gyroscope Automatic Bias Null Calibration

Set GLOB_CMD[0] = 1 (DIN = 0xBE01) to execute the automatic bias null calibration function. This function measures all three gyroscope output registers and then loads each gyroscope offset register with the opposite value to provide a quick bias calibration. All sensor data is then reset to 0, and the flash memory is updated automatically within 50 ms (see Table 17).

Gyroscope Precision Automatic Bias Null Calibration

Set GLOB_CMD[4] = 1 (DIN = 0xBE10) to execute the precision automatic bias null calibration function. This function takes the sensor offline for 30 sec while it collects a set of data and calculates more accurate bias correction factors for each gyroscope. After this function is executed, the newly calculated correction factor is loaded into the gyroscope offset registers, all sensor data is reset to 0, and the flash memory is updated automatically within 50 ms (see Table 17).

Restoring Factory Calibration

Set GLOB_CMD[1] = 1 (DIN = 0xBE02) to execute the factory calibration restore function. This function resets each user calibration register to 0x0000 (see Table 15 and Table 16), resets all sensor data to 0, and automatically updates the flash memory within 50 ms (see Table 17).

Linear Acceleration Bias Compensation (Gyroscope)

Set MSC_CTRL[7] = 1 (DIN = 0xB486) to enable correction for low frequency acceleration influences on gyroscope bias. Note that the DIN sequence also preserves the factory default condition for the data ready function (see Table 22).

OPERATIONAL CONTROL

Global Commands

The GLOB_CMD register provides trigger bits for several useful functions. Setting the assigned bit to 1 starts each operation, which returns the bit to 0 after completion. For example, set GLOB_CMD[7] = 1 (DIN = 0xBE80) to execute a software reset, which stops the sensor operation and runs the device through its start-up sequence. This sequence includes loading the control registers with the data in their respective flash memory locations prior to producing new data. Reading the GLOB_CMD register (DIN = 0x3E00) starts the burst read sequence.

Table 17. GLOB_CMD Bit Descriptions

Bits	Description (Default = 0x0000)
[15:8]	Not used.
[7]	Software reset command.
[6:5]	Not used.
[4]	Precision autonull command.
[3]	Flash update command.
[2]	Auxiliary DAC data latch.
[1]	Factory calibration restore command.
[0]	Autonull command.

Internal Sample Rate

The SMPL_PRD register provides discrete sample period settings using the bit assignments in Table 18 and the following equation:

$$t_s = t_B \times (N_s + 1)$$

For example, when SMPL_PRD[7:0] = 0x0A, the sample rate is 149 SPS.

Table 18. SMPL_PRD Bit Descriptions

Bits	Description (Default = 0x0001)
[15:8]	Not used
[7]	Time base (t_B) 0 = 0.61035 ms, 1 = 18.921 ms
[6:0]	Increment setting (N_s) Internal sample period = $t_s = t_B \times (N_s + 1)$

The default sample rate setting of 819.2 SPS preserves the sensor bandwidth and provides optimal performance. For systems that value slower sample rates, keep the internal sample rate at 819.2 SPS. Use the programmable filter (SENS_AVG) to reduce the bandwidth, which helps to prevent aliasing. The data ready function (MSC_CTRL) can drive an interrupt routine that uses a counter to help ensure data coherence at the reduced rates.

Power Management

Setting $SMPL_PRD \geq 0x0A$ also sets the sensor to low power mode. For systems that require lower power dissipation, in-system characterization helps users to quantify the associated performance trade-offs. In addition to sensor performance, this mode affects SPI data rates (see Table 2). Set $SLP_CNT[8] = 1$ ($DIN = 0xBB01$) to start the indefinite sleep mode, which requires a \overline{CS} assertion (high to low), reset, or power cycle to wake up. Use $SLP_CNT[7:0]$ to put the device into sleep mode for a specified period. For example, $SLP_CNT[7:0] = 0x64$ ($DIN = 0xBA64$) puts the ADIS16360/ADIS16365 to sleep for 50 sec.

Table 19. SLP_CNT Bit Descriptions

Bits	Description (Default = 0x0000)
[15:9]	Not used
[8]	Indefinite sleep mode; set to 1
[7:0]	Programmable sleep time bits, 0.5 sec/LSB

Sensor Bandwidth

The signal chain for each MEMS sensor has several filter stages, which shape their frequency response. Figure 14 provides a block diagram for both gyroscope and accelerometer signal paths. Table 20 provides additional information for digital filter configuration.

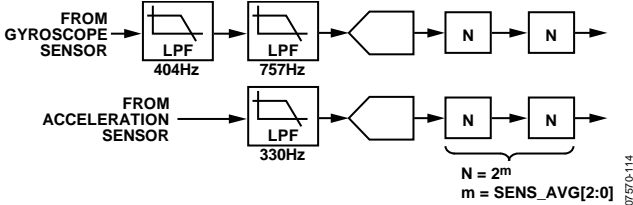

Figure 14. MEMS Analog and Digital Filters

Digital Filtering

The N blocks in Figure 14 are part of the programmable low-pass filter, which provides additional noise reduction on the inertial sensor outputs. This filter contains two cascaded averaging filters that provide a Bartlett window, FIR filter response (see Figure 15). For example, set $SENS_AVG[2:0] = 100$ ($DIN = 0xB804$) to set each stage to 16 taps. When used with the default sample rate of 819.2 SPS, this value reduces the sensor bandwidth to approximately 16 Hz.

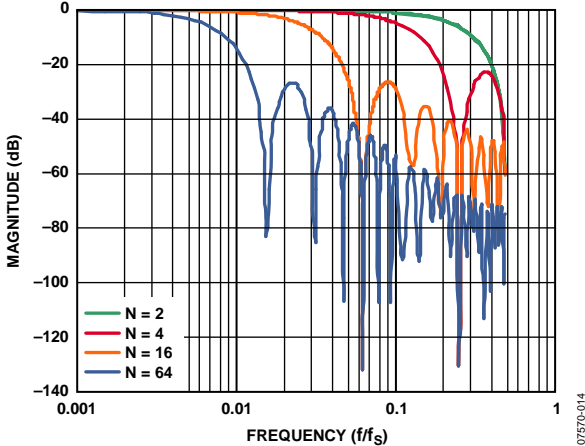

Figure 15. Bartlett Window, FIR Filter Frequency Response (Phase Delay = N Samples)

Dynamic Range

The $SENS_AVG[10:8]$ bits provide three dynamic range settings for this gyroscope. The lower dynamic range settings ($\pm 75^\circ/sec$ and $\pm 150^\circ/sec$) limit the minimum filter tap sizes to maintain resolution. For example, set $SENS_AVG[10:8] = 010$ ($DIN = 0xB902$) for a measurement range of $\pm 150^\circ/sec$. Because this setting can influence the filter settings, program $SENS_AVG[10:8]$ and then $SENS_AVG[2:0]$ if more filtering is required.

Table 20. SENS_AVG Bit Descriptions

Bits	Description (Default = 0x0402)
[15:11]	Not used
[10:8]	Measurement range (sensitivity) selection 100 = $\pm 300^\circ/sec$ (default condition) 010 = $\pm 150^\circ/sec$, filter taps ≥ 4 ($Bits[2:0] \geq 0x02$) 001 = $\pm 75^\circ/sec$, filter taps ≥ 16 ($Bits[2:0] \geq 0x04$)
[7:3]	Not used
[2:0]	Number of taps in each stage; value of m in $N = 2^m$

ADIS16360/ADIS16365

INPUT/OUTPUT FUNCTIONS

General-Purpose I/O

DIO1, DIO2, DIO3, and DIO4 are configurable, general-purpose I/O lines that serve multiple purposes according to the following control register priority: MSC_CTRL, ALM_CTRL, and GPIO_CTRL. For example, set GPIO_CTRL = 0x080C (DIN = 0xB308, and then 0xB20C) to configure DIO1 and DIO2 as inputs and DIO3 and DIO4 as outputs, with DIO3 set low and DIO4 set high.

In this configuration, read GPIO_CTRL (DIN = 0x3200). The digital state of DIO1 and DIO2 is in GPIO_CTRL[9:8].

Table 21. GPIO_CTRL Bit Descriptions

Bits	Description (Default = 0x0000)
[15:12]	Not used
[11]	General-Purpose I/O Line 4 (DIO4) data level
[10]	General-Purpose I/O Line 3 (DIO3) data level
[9]	General-Purpose I/O Line 2 (DIO2) data level
[8]	General-Purpose I/O Line 1 (DIO1) data level
[7:4]	Not used
[3]	General-Purpose I/O Line 4 (DIO4) direction control (1 = output, 0 = input)
[2]	General-Purpose I/O Line 3 (DIO3) direction control (1 = output, 0 = input)
[1]	General-Purpose I/O Line 2 (DIO2) direction control (1 = output, 0 = input)
[0]	General-Purpose I/O Line 1 (DIO1) direction control (1 = output, 0 = input)

Input Clock Configuration

The input clock configuration function allows for external control of sampling in the ADIS16360/ADIS16365. Set GPIO_CTRL[3] = 0 (DIN = 0x0B200) and SMPL_PRD[7:0] = 0x00 (DIN = 0xB600) to enable this function. See Table 2 and Figure 4 for timing information.

Data Ready I/O Indicator

The factory default sets DIO1 as a positive data ready indicator signal. The MSC_CTRL[2:0] bits provide configuration options for changing the default. For example, set MSC_CTRL[2:0] = 100 (DIN = 0xB404) to change the polarity of the data ready signal on DIO1 for interrupt inputs that require negative logic inputs for activation. The pulse width is between 100 μ s and 200 μ s over all conditions.

Table 22. MSC_CTRL Bit Descriptions

Bits	Description (Default = 0x0006)
[15:12]	Not used
[11]	Memory test (cleared upon completion) (1 = enabled, 0 = disabled)
[10]	Internal self-test enable (cleared upon completion) (1 = enabled, 0 = disabled)
[9]	Manual self-test, negative stimulus (1 = enabled, 0 = disabled)
[8]	Manual self-test, positive stimulus (1 = enabled, 0 = disabled)
[7]	Linear acceleration bias compensation for gyroscopes (1 = enabled, 0 = disabled)
[6]	Linear accelerometer origin alignment (1 = enabled, 0 = disabled)
[5:3]	Not used
[2]	Data ready enable (1 = enabled, 0 = disabled)
[1]	Data ready polarity (1 = active high, 0 = active low)
[0]	Data ready line select (1 = DIO2, 0 = DIO1)

Auxiliary DAC

The 12-bit AUX_DAC line can drive its output to within 5 mV of the ground reference when it is not sinking current. As the output approaches 0 V, the linearity begins to degrade (~100 LSB starting point). As the sink current increases, the nonlinear range increases. The DAC latch command moves the values of the AUX_DAC register into the DAC input register, enabling both bytes to take effect at the same time.

Table 23. AUX_DAC Bit Descriptions

Bits	Description (Default = 0x0000)
[15:12]	Not used
[11:0]	Data bits, scale factor = 0.8059 mV/LSB Offset binary format, 0 V = 0 LSB

Table 24. Setting AUX_DAC = 1 V

DIN	Description
0xB0D9	AUX_DAC[7:0] = 0xD9 (217 LSB).
0xB104	AUX_DAC[15:8] = 0x04 (1024 LSB).
0xBE04	GLOB_CMD[2] = 1. Move values into the DAC input register, resulting in a 1 V output level.

DIAGNOSTICS

Self-Test

The self-test function allows the user to verify the mechanical integrity of each MEMS sensor. It applies an electrostatic force to each sensor element, which results in mechanical displacement that simulates a response to actual motion. Table 1 lists the expected response for each sensor, which provides pass/fail criteria.

Set MSC_CTRL[10] = 1 (DIN = 0xB504) to run the internal self-test routine, which exercises all inertial sensors, measures each response, makes pass/fail decisions, and reports them to error flags in the DIAG_STAT register. MSC_CTRL[10] resets itself to 0 after completing the routine. The MSC_CTRL[9:8] bits provide manual control over the self-test function for investigation of potential failures. Table 25 outlines an example test flow for using this option to verify the x-axis gyroscope function.

Table 25. Manual Self-Test Example Sequence

DIN	Description
0xB601	SMPL_PRD[7:0] = 0x01, sample rate = 819.2 SPS.
0xB904	SENS_AVG[15:8] = 0x04, gyro range = ±300°/sec.
0xB802	SENS_AVG[7:0] = 0x02, four-tap averaging filter. Delay = 50 ms.
0x0400	Read XGYRO_OUT.
0xB502	MSC_CTRL[9:8] = 10, gyroscope negative self-test. Delay = 50 ms.
0x0400	Read XGYRO_OUT. Determine whether the bias in the gyroscope output changed according to the self-test response specified in Table 1.
0xB501	MSC_CTRL[9:8] = 01, gyroscope/accelerometer positive self-test. Delay = 50 ms.
0x0400	Read XGYRO_OUT. Determine whether the bias in the gyroscope output changed according to the self-test response specified in Table 1.
0xB500	MSC_CTRL[15:8] = 0x00.

Zero motion provides results that are more reliable. The settings in Table 25 are flexible and allow for optimization around speed and noise influence. For example, using fewer filtering taps decreases delay times but increases the possibility of noise influence.

Memory Test

Setting MSC_CTRL[11] = 1 (DIN = 0xB508) performs a checksum verification of the flash memory locations. The pass/fail result is loaded into DIAG_STAT[6].

Status

The error flags provide indicator functions for common system level issues. All of the flags are cleared (set to 0) after each DIAG_STAT register read cycle. If an error condition remains, the error flag returns to 1 during the next sample cycle. The DIAG_STAT[1:0] bits do not require a read of this register to return to 0. If the power supply voltage goes back into range, these two flags are cleared automatically.

Table 26. DIAG_STAT Bit Descriptions

Bits	Description (Default = 0x0000)
[15]	Z-axis accelerometer self-test failure (1 = fail, 0 = pass)
[14]	Y-axis accelerometer self-test failure (1 = fail, 0 = pass)
[13]	X-axis accelerometer self-test failure (1 = fail, 0 = pass)
[12]	Z-axis gyroscope self-test failure (1 = fail, 0 = pass)
[11]	Y-axis gyroscope self-test failure (1 = fail, 0 = pass)
[10]	X-axis gyroscope self-test failure (1 = fail, 0 = pass)
[9]	Alarm 2 status (1 = active, 0 = inactive)
[8]	Alarm 1 status (1 = active, 0 = inactive)
[7]	Not used
[6]	Flash test, checksum flag (1 = fail, 0 = pass)
[5]	Self-test diagnostic error flag (1 = fail, 0 = pass)
[4]	Sensor overrange (1 = fail, 0 = pass)
[3]	SPI communication failure (1 = fail, 0 = pass)
[2]	Flash update failure (1 = fail, 0 = pass)
[1]	Power supply > 5.25 V 1 = power supply > 5.25 V, 0 = power supply ≤ 5.25 V
[0]	Power supply < 4.75 V 1 = power supply < 4.75 V, 0 = power supply ≥ 4.75 V

Alarm Registers

The alarm function provides monitoring for two independent conditions. The ALM_CTRL register provides control inputs for data source, data filtering (prior to comparison), static comparison, dynamic rate-of-change comparison, and output indicator configurations. The ALM_MAGx registers establish the trigger threshold and polarity configurations. Table 30 gives an example of how to configure a static alarm. The ALM_SMPLx registers provide the numbers of samples to use in the dynamic rate-of-change configuration. The period equals the number in the ALM_SMPLx register multiplied by the sample period time, which is established by the SMPL_PRD register. See Table 31 for an example of how to configure the sensor for this type of function.

ADIS16360/ADIS16365

Table 27. ALM_MAG1, ALM_MAG2 Bit Descriptions

Bits	Description (Default = 0x0000)
[15]	Comparison polarity (1 = greater than, 0 = less than)
[14]	Not used
[13:0]	Data bits that match the format of the trigger source selection

Table 28. ALM_SMPL1, ALM_SMPL2 Bit Descriptions

Bits	Description (Default = 0x0000)
[15:8]	Not used
[7:0]	Data bits: number of samples (both 0x00 and 0x01 = 1)

Table 29. ALM_CTRL Bit Descriptions

Bits	Description (Default = 0x0000)
[15:12]	Alarm 2 source selection 0000 = disable 0001 = power supply output 0010 = x-axis gyroscope output 0011 = y-axis gyroscope output 0100 = z-axis gyroscope output 0101 = x-axis accelerometer output 0110 = y-axis accelerometer output 0111 = z-axis accelerometer output 1000 = x-axis gyroscope temperature output 1001 = y-axis gyroscope temperature output 1010 = z-axis gyroscope temperature output 1011 = auxiliary ADC input
[11:8]	Alarm 1 source selection (same as Alarm 2)
[7]	Rate-of-change enable for Alarm 2 (1 = rate of change, 0 = static level)
[6]	Rate-of-change enable for Alarm 1 (1 = rate of change, 0 = static level)
[5]	Not used
[4]	Comparison data filter setting (1 = filtered data, 0 = unfiltered data)
[3]	Not used
[2]	Alarm output enable (1 = enabled, 0 = disabled)
[1]	Alarm output polarity (1 = active high, 0 = active low)
[0]	Alarm output line select (1 = DIO2, 0 = DIO1)

Table 30. Alarm Configuration Example 1

DIN	Description
0xAF55, 0xAE17	ALM_CTRL = 0x5517. Alarm 1 input = XACCL_OUT. Alarm 2 input = XACCL_OUT. Static level comparison, filtered data. DIO2 output indicator, positive polarity.
0xA783, 0xA641	ALM_MAG1 = 0x8341. Alarm 1 is true if XACCL_OUT > +0.5 g.
0xA93C, 0xA8BF	ALM_MAG2 = 0x3CBF. Alarm 2 is true if XACCL_OUT < -0.5 g.

Table 31. Alarm Configuration Example 2

DIN	Description
0xAF76, 0xAEC7	ALM_CTRL = 0x76C7. Alarm 1 input = YACCL_OUT. Alarm 2 input = ZACCL_OUT. Rate-of-change comparison, unfiltered data. DIO2 output indicator, positive polarity.
0xB601	SMPL_PRD = 0x0001. Sample rate = 819.2 SPS.
0xAB08	ALM_SMPL1 = 0x0008. Alarm 1 rate-of-change period = 9.77 ms.
0xAC50	ALM_SMPL2 = 0x0050. Alarm 2 rate-of-change period = 97.7 ms.
0xA783, 0xA641	ALM_MAG1 = 0x8341. Alarm 1 is true if YACCL_OUT increases by more than 0.5 g in 9.77 ms.
0xA93C, 0xA8BE	ALM_MAG2 = 0x3CBE. Alarm 2 is true if ZACCL_OUT decreases by more than 0.5 g in 97.7 ms.

PRODUCT IDENTIFICATION

Table 32 provides a summary of the registers that identify the product: PROD_ID, which identifies the product type; LOT_ID1 and LOT_ID2, the 32-bit lot identification code; and SERIAL_NUM, which displays the 16-bit serial number. All four registers are two bytes in length.

Table 32. Identification Registers

Register Name	Address	Description
LOT_ID1	0x52	Lot Identification Code 1
LOT_ID2	0x54	Lot Identification Code 2
SERIAL_NUM	0x56	Serial number
PROD_ID	0x58	Product identification: 0x3FE8 (16,360) 0x3FED (16,365)

APPLICATIONS INFORMATION

INSTALLATION/HANDLING

For ADIS16360/ADIS16365 installation, use the following two-step process:

1. Secure the baseplate using machine screws.
2. Press the connector into its mate.

For removal,

1. Gently pry the connector from its mate using a small slot screwdriver.
2. Remove the screws and lift the part up.

Never attempt to unplug the connector by pulling on the plastic case or baseplate. Although the flexible connector is very reliable in normal operation, it can break when subjected to unreasonable handling. When broken, the flexible connector cannot be repaired. The AN-1041 Application Note provides more information about developing an appropriate mechanical interface design (see www.analog.com).

GYROSCOPE BIAS OPTIMIZATION

The factory calibration addresses initial bias errors along with temperature-dependent bias behaviors. Installation and certain environmental conditions can introduce modest bias errors. The precision autonull command (GLOB_CMD[4]) provides a simple predeployment method for correcting these errors to an accuracy of approximately 0.008°/sec, using an average of 30 sec. Averaging the sensor output data for 100 sec can provide incremental performance gains, as well. Controlling device rotation, power supply, and temperature during these averaging times helps to ensure optimal accuracy during this process. Refer to the AN-1041 Application Note for more information about optimizing performance.

INPUT ADC CHANNEL

The AUX_ADC register provides access to the auxiliary ADC input channel. The ADC is a 12-bit successive approximation converter that has an input circuit equivalent to the one shown in Figure 16. The maximum input is 3.3 V. The ESD protection diodes can handle 10 mA without causing irreversible damage. The on resistance (R1) of the switch has a typical value of 100 Ω. The sampling capacitor, C2, has a typical value of 16 pF.

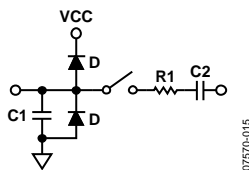
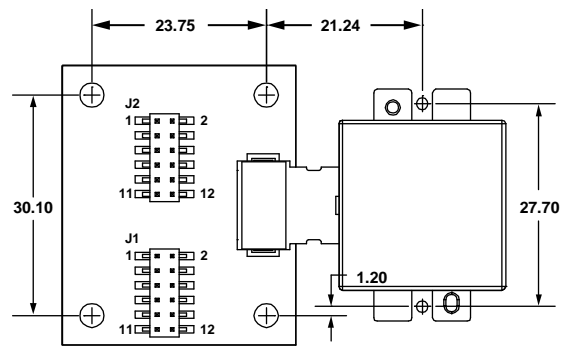

Figure 16. Equivalent Analog Input Circuit
(Conversion Phase: Switch Open,
Track Phase: Switch Closed)

INTERFACE PRINTED CIRCUIT BOARD (PCB)

The ADIS16360/PCBZ includes one ADIS16360BMLZ and one interface PCB. The ADIS16365/PCBZ includes one ADIS16365BMLZ and one interface PCB. The interface PCB simplifies the process of integrating these products into an existing processor system.

J1 and J2 are dual-row, 2 mm (pitch) connectors that work with a number of ribbon cable systems, including 3M Part Number 152212-0100-GB (ribbon crimp connector) and 3M Part Number 3625/12 (ribbon cable). Figure 17 provides a hole pattern design for installing the ADIS16360BMLZ/ADIS16365BMLZ and the interface PCB onto the same surface. Figure 18 provides the pin assignments for each connector. The pin descriptions match those listed in Table 5. The ADIS16360/ADIS16365 do not require external capacitors for normal operation, so the interface PCB does not use the C1/C2 pads (not shown in Figure 17).



NOTES
1. DIMENSIONS IN MILLIMETERS.

Figure 17. Physical Diagram for the ADIS16360/PCBZ and ADIS16365/PCBZ

J1				J2			
RST	1	2	SCLK	AUX_ADC	1	2	GND
CS	3	4	DOUT	AUX_DAC	3	4	DIO3
DNC	5	6	DIN	GND	5	6	DIO4
GND	7	8	GND	DNC	7	8	DNC
GND	9	10	VCC	DNC	9	10	DNC
VCC	11	12	VCC	DIO2	11	12	DIO1

Figure 18. J1/J2 Pin Assignments

ADIS16360/ADIS16365

OUTLINE DIMENSIONS

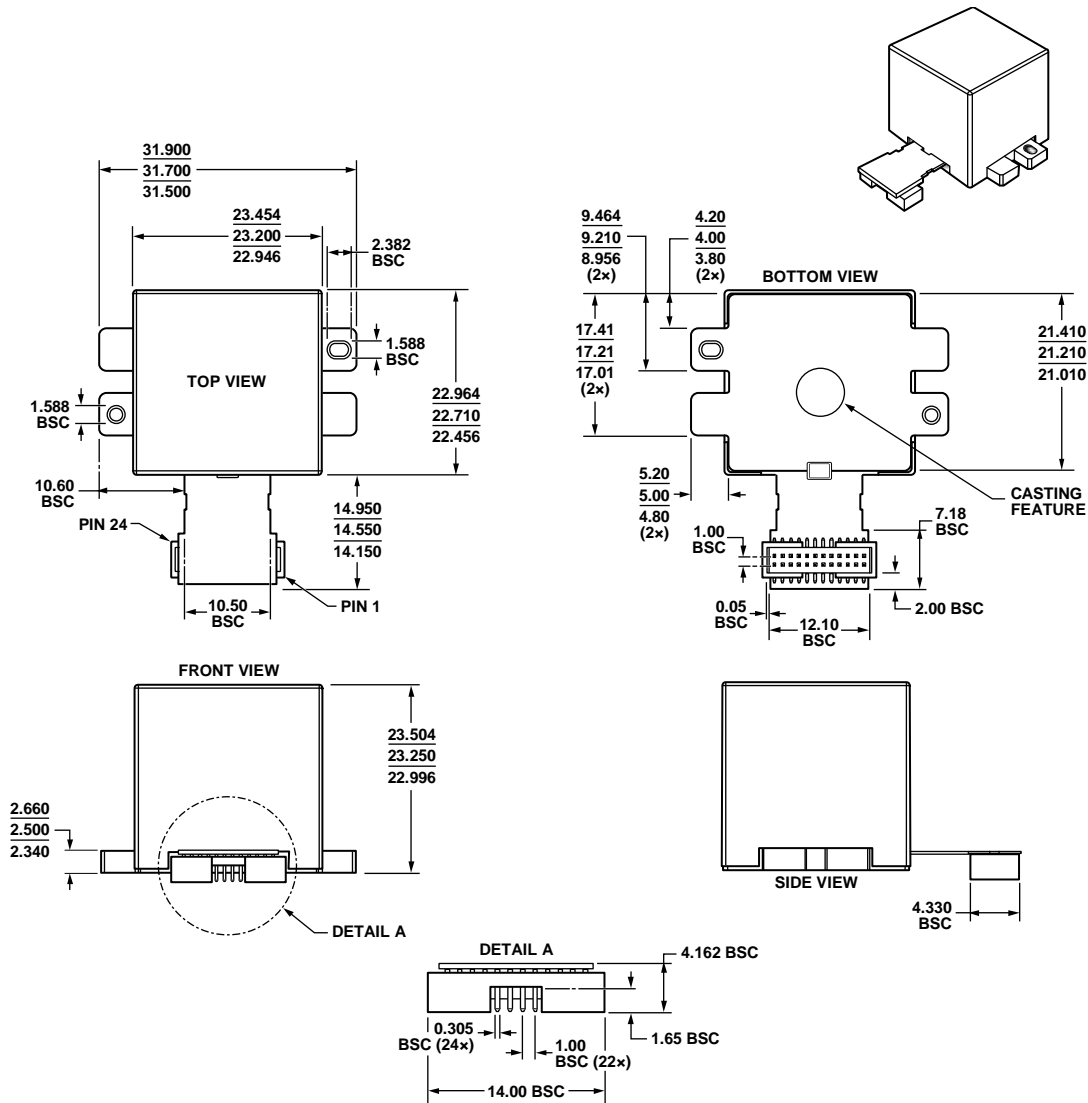

Figure 19. 24-Lead Module with Connector Interface (ML-24-2)
Dimensions shown in millimeters

122206-C

ORDERING GUIDE

Model ¹	Temperature Range	Package Description	Package Option
ADIS16360BMLZ	-40°C to +105°C	24-Lead Module with Connector Interface	ML-24-2
ADIS16360/PCBZ		Interface Board	
ADIS16365BMLZ	-40°C to +105°C	24-Lead Module with Connector Interface	ML-24-2
ADIS16365/PCBZ		Interface Board	

¹ Z = RoHS Compliant Part.

NOTES

NOTES