

PI33/PI34/PI35xx Series

Cool-Power® ZVS Switching Regulators: Buck

48, 24 and 12V to PoL Buck Regulator Applications, Computing, Communications, Industrial, Automotive Equipment. Constant current applications: LED Lighting and Battery Charging.

Description

PI33/PI34/PI35xx Cool-Power® ZVS Buck Regulators offer board-level designers maximum power density and flexibility for high-efficiency point-of-load DC-DC regulation. The integration of a high performance Zero-Voltage Switching (ZVS) topology increases point-of-load performance, providing best-in-class power efficiency up to 98%. Cool-Power ZVS Regulators are highly integrated with control circuitry, power semiconductors and support components in a high density LGA System in Package (SiP).

Power delivery can be further increased by inter-leaving multiple buck regulators using single wire current sharing. The ZVS topology enables high-frequency operation maximizing efficiency by minimizing the significant switching losses associated with conventional hard switching buck regulators. The high switching frequency of the Cool-Power ZVS Regulators reduces the size of the external filtering components, improving power density while enabling fast line and load dynamic response. These regulators maintain high switching frequency all the way up to the rated input voltage without sacrificing efficiency and, with its 20ns minimum on-time, supports step down conversion for input voltages up to 60V. The Cool-Power ZVS series offers buck regulators for 12V_{IN}, 24V_{IN}, and 48V_{IN} nominal systems. Packaging of the bucks is either in a 10 x 10 x 2.5mm or 10 x 14 x 2.5mm LGA package. All devices within their respective series share the same footprint.



Example Power Chain

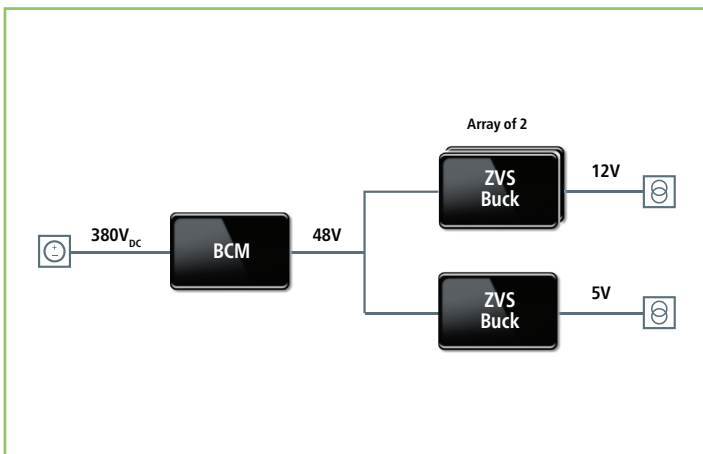

Features & Benefits

- Wide Input Operating Ranges
 - 12V_{IN} nominal (8 to 18V_{IN})
 - 24V_{IN} nominal (8 to 36V_{IN})
 - 48V_{IN} nominal (30 to 60V_{IN})
 - -40°C to 125°C temperature operating range
- Simple to Use; Fast Development Time
 - Internal compensation - few external components
 - No additional design or additional settings required
- High Efficiency
 - >96% peak 48V_{IN} to 12V_{OUT}
 - >96% peak 24V_{IN} to 12V_{OUT}
 - >95% peak 12V_{IN} to 5V_{OUT}
 - Light load and full load high efficiency performance
- Flexible and Rich Feature Set
 - Paralleling and single wire current sharing
 - Frequency synchronization
 - User adjustable soft-start & tracking
 - PI33xx optional I²C™ telemetry & functionality
 - V_{OUT} margining
 - Fault reporting
 - Enable and SYNC1 pin polarity
 - Phase delay (for interleaving multiple regulators)
- High Density Packaging Platform
 - 10 x 14 x 2.5mm SiP LGA
 - 10 x 10 x 2.5mm SiP LGA

Total Area (With Required Components)

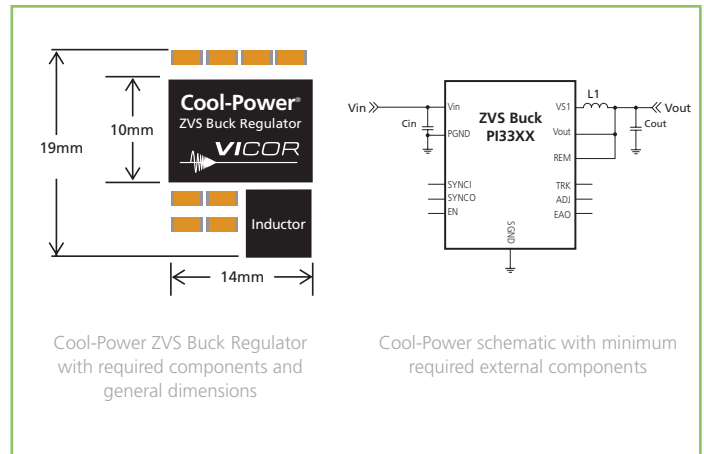

PI34xx Efficiency (5V_{OUT})

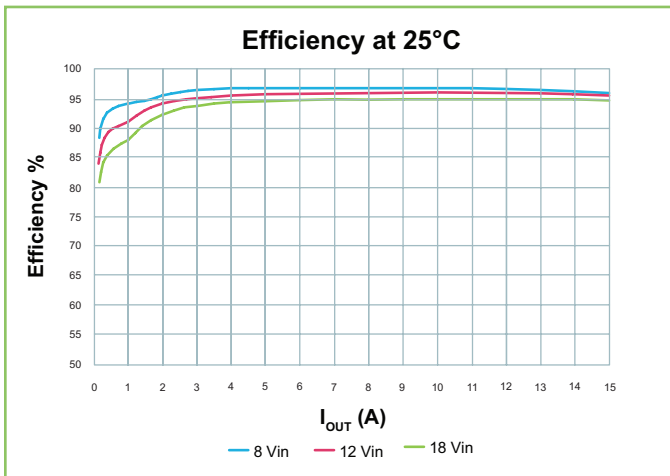

PI33xx Efficiency (12V_{OUT})

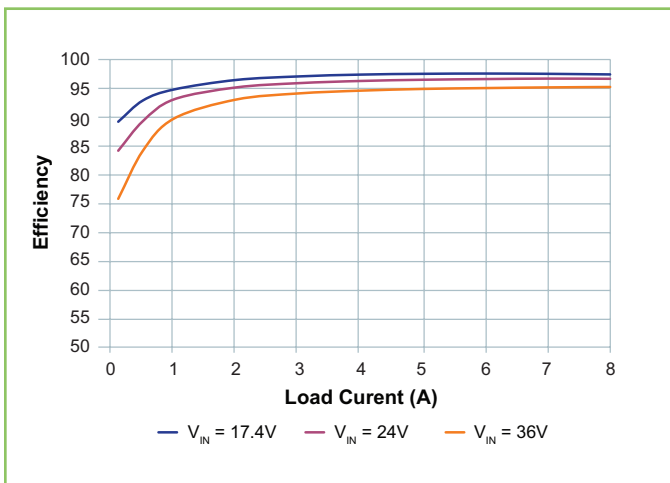

PI35xx Efficiency (12V_{OUT})

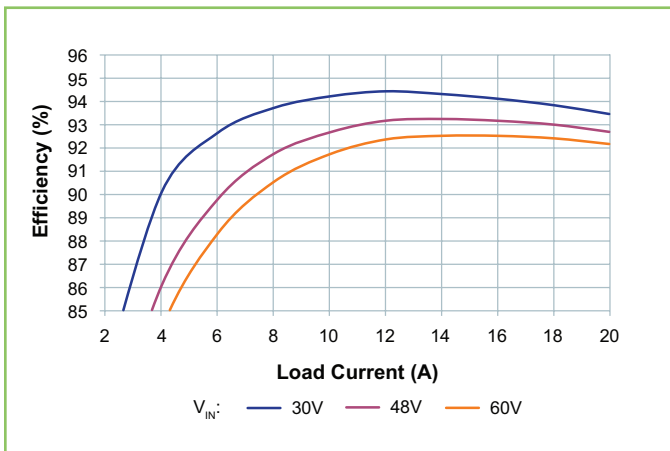

Part Numbers

	Output Range		Rating
	Set	Range	
12V (8 – 18V_{IN})			
PI3420-00-LGIZ	1.0V	1.0 – 1.4V	15A
PI3421-00-LGIZ	1.8V	1.4 – 2.0V	15A
PI3422-00-LGIZ	2.5V	2.0 – 3.1V	15A
PI3423-00-LGIZ	3.3V	2.3 – 4.1V	15A
PI3424-00-LGIZ	5.0V	3.3 – 6.5V	15A
24V (8 – 36V_{IN})			
PI3311-00-LGIZ	1.0V	1.0 – 1.4V	10A
PI3311-01-LGIZ	1.0V	1.0 – 1.4V	15A
PI3318-00-LGIZ	1.8V	1.4 – 2.0V	10A
PI3318-01-LGIZ	1.8V	1.4 – 2.0V	15A
PI3312-00-LGIZ	2.5V	2.0 – 3.1V	10A
PI3312-01-LGIZ	2.5V	2.0 – 3.1V	15A
PI3301-00-LGIZ	3.3V	2.3 – 4.1V	10A
PI3301-01-LGIZ	3.3V	2.3 – 4.1V	15A
PI3302-00-LGIZ	5.0V	3.3 – 6.5V	10A
PI3302-03-LGIZ ^[a]	5V	3.3 – 6.5V	15A
PI3303-00-LGIZ	12V	6.5 – 13.0V	8A
PI3305-00-LGIZ	15V	10.0 – 16.0V	8A
24 V_{IN} (8 – 36V_{IN}) I²C™^[b] Functionality			
PI3311-20-LGIZ	1.0V	1.0 – 1.4V	10A
PI3311-21-LGIZ	1.0V	1.0 – 1.4V	15A
PI3318-20-LGIZ	1.8V	1.4 – 2.0V	10A
PI3318-21-LGIZ	1.8V	1.4 – 2.0V	15A
PI3312-20-LGIZ	2.5V	2.0 – 3.1V	10A
PI3312-21-LGIZ	2.5V	2.0 – 3.1V	15A
PI3301-20-LGIZ	3.3V	2.3 – 4.1V	10A
PI3301-21-LGIZ	3.3V	2.3 – 4.1V	15A
PI3302-20-LGIZ	5.0V	3.3 – 6.5V	10A
PI3302-21-LGIZ	5.0V	3.3 – 6.5V	15A
PI3303-20-LGIZ	12V	6.5 – 13.0V	8A
PI3305-20-LGIZ	15V	10.0 – 16.0V	8A
48V (30 – 60V_{IN})			
PI3525-00-LGIZ	5.0V	4.0 – 6.5V	20A
PI3526-00-LGIZ	12.0V	6.5 – 14V	18A
48V (36 – 60V_{IN})			
PI3542-00-LGIZ	2.5V	2.2 – 3.0V	10A
PI3543-00-LGIZ	3.3V	2.6 – 3.6V	10A
PI3545-00-LGIZ	5.0V	4.0 – 5.5V	10A
PI3546-00-LGIZ	12.0V	6.5 – 14.0V	9A

^[a] Input operating range is limited to 11V to 36V

^[b] I²C is a trademark of NXP Semiconductors