

Controller - PLC-V8C/SC-24DC/BM - 2903094

Please be informed that the data shown in this PDF Document is generated from our Online Catalog. Please find the complete data in the user's documentation. Our General Terms of Use for Downloads are valid (<http://phoenixcontact.com/download>)



PLC logic basic logic module, generation 1, with 16 I/Os, can be plugged onto 8 digital PLC-INTERFACE terminal blocks, can be extended to 48 I/Os, realtime clock, accommodates memory module and Bluetooth adapter (firmware update required, see downloads), screw connection

RoHS

Key Commercial Data

Packing unit	1 STK
GTIN	
GTIN	4046356712842

Technical data

Note

Utilization restriction	EMC: class A product, see manufacturer's declaration in the download area
-------------------------	---

Power supply

Supply voltage	24 V DC
Supply voltage range	19.2 V DC ... 26.4 V DC
Maximum input current at U_N	120 mA
Protective circuit	Reverse polarity protection
	Surge protection
Status display	Green LED

Input data (digital)

Number of inputs	8 (2 configurable as analog)
Description of the input	EN 61131-2, type 3
Input voltage	24 V DC
Signal level "0" signal	< 5 V
Signal level "1" signal	> 11 V
Input current "0" signal	< 1 mA
Input current "1" signal	typ. 2.5 mA

Controller - PLC-V8C/SC-24DC/BM - 2903094

Technical data

Input data (digital)

Status display	Yellow LED
----------------	------------

Input data (analog)

Number of inputs	2 (IN6 and IN7 are configurable as analog)
Input voltage range	0 V ... 10 V
Input resistance	> 3.5 kΩ

Input data (PLC-INTERFACE)

Number of inputs	≤ 8
Description of the input	technical data depends on the PLC used
Input voltage	19 V DC
Typical current consumption	4 mA
Input resistance	< 100 mΩ

Output data

Number of outputs	≤ 8
Nominal output voltage	24 V DC
Nominal current	9 mA

General

Realtime clock accuracy	±2 s/d
Realtime clock buffer time	24 h (Capacitor)
Color	green
Mounting position	any
Assembly instructions	Can be plugged onto 8 x PLC-INTERFACE
Operating mode	100% operating factor
Degree of protection	IP20

Connection data (supply and digital inputs)

Connection method	Screw connection
Stripping length	7 mm
Screw thread	M2
Conductor cross section solid	0.14 mm ² ... 1.5 mm ²
Conductor cross section flexible	0.14 mm ² ... 1.5 mm ²
	0.25 mm ² ... 0.5 mm ² (Ferrule with plastic sleeve)
	0.25 mm ² ... 1.5 mm ² (Ferrules without plastic sleeve)
Conductor cross section AWG	28 ... 16
Number of connections	1
Number of positions	10
Note	Device supply and 8 x inputs

Connection data (programming interface)

Connection method	Micro USB type B
Number of connections	1

Controller - PLC-V8C/SC-24DC/BM - 2903094

Technical data

Connection data (INTERFACE system)

Connection method	Spring-cage connection
Stripping length	6 mm
Conductor cross section solid	0.14 mm ² ... 0.5 mm ²
Conductor cross section flexible	0.2 mm ² ... 0.5 mm ²
Conductor cross section AWG	26 ... 20
Number of connections	1
Number of positions	3

Connection data (PLC V8C bus)

Connection method	Insulation displacement connection
Number of connections	1
Number of positions	4

Connection data (memory)

Connection method	S-PORT (socket)
Number of connections	1
Number of positions	12
Note	For connecting the memory module

Ambient conditions

Ambient temperature (operation)	-20 °C ... 45 °C
Ambient temperature (storage/transport)	-20 °C ... 70 °C
Max. permissible relative humidity (operation)	95 %

Dimensions

Width	50 mm
Height	106 mm
Depth	87 mm

Standards and Regulations

Designation	Air clearances and creepage distances between the power circuits
Standards/regulations	DIN EN 50178
Rated insulation voltage	50 V
Rated surge voltage	0.8 kV
Insulation	Basic insulation
Degree of pollution	2
Overvoltage category	III
Conformance	CE-compliant

Environmental Product Compliance

China RoHS	Environmentally Friendly Use Period = 50
	For details about hazardous substances go to tab "Downloads", Category "Manufacturer's declaration"

Controller - PLC-V8C/SC-24DC/BM - 2903094

Drawings

Dimensional drawing

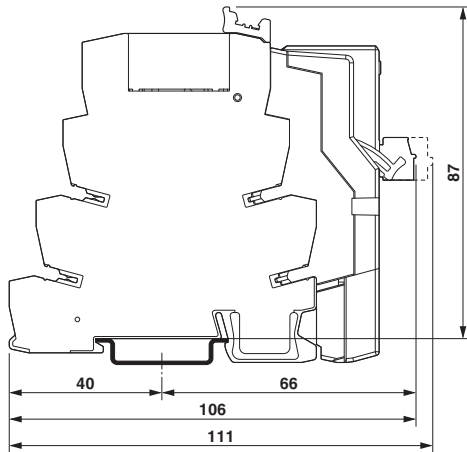

Circuit diagram

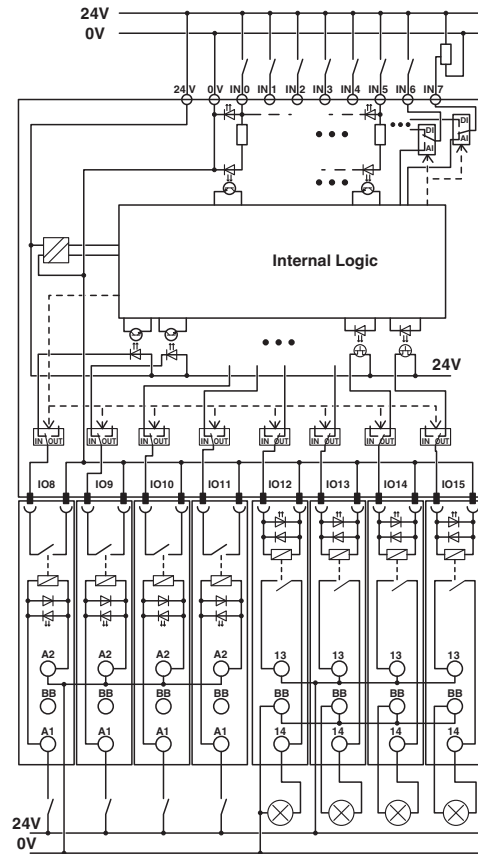

Circuit diagram

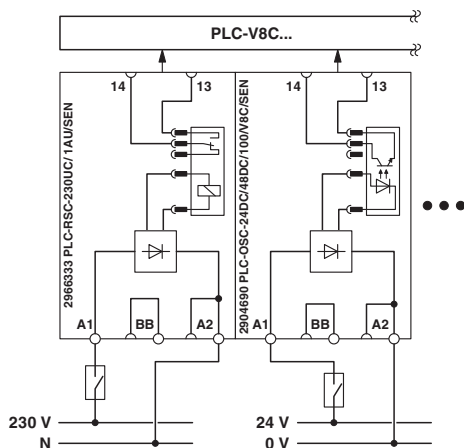

Circuit diagram

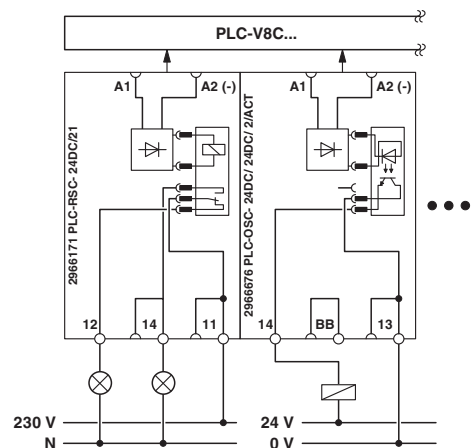

Basic circuit diagram: inputs via PLC-INTERFACE with the example of one input terminal block with relay (230 V AC) and one input terminal block with solid-state relay (24 V DC).

Basic circuit diagram: outputs via PLC-INTERFACE with the example of an output terminal block with relay, 1 PDT, and an output terminal block with solid-state relay.

Controller - PLC-V8C/SC-24DC/BM - 2903094

Connection diagram

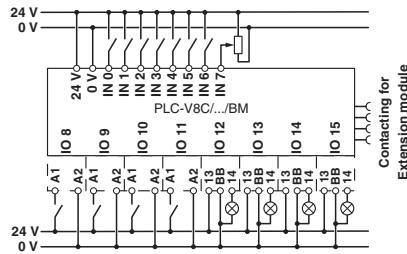

Circuit diagram

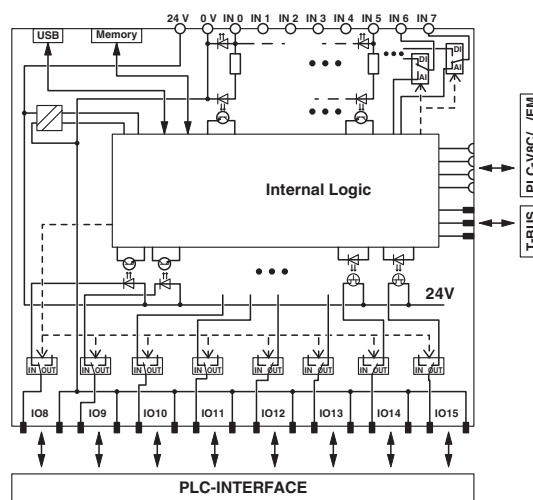

Approvals

Approvals

Approvals

UL Listed / cUL Listed / cULus Listed

Ex Approvals

Approval details

UL Listed



<http://database.ul.com/cgi-bin/XYV/template/LISEXT/1FRAME/index.htm>

FILE E 172140

Controller - PLC-V8C/SC-24DC/BM - 2903094

Approvals

cUL Listed



<http://database.ul.com/cgi-bin/XYV/template/LISEXT/1FRAME/index.htm> FILE E 172140

cULus Listed



Phoenix Contact 2017 © - all rights reserved
<http://www.phoenixcontact.com>

PHOENIX CONTACT GmbH & Co. KG
Flachsmarktstr. 8
32825 Blomberg
Germany
Tel. +49 5235 300
Fax +49 5235 3 41200
<http://www.phoenixcontact.com>