

# NHD-4.3-480272EF-ASXN#-CTP

## TFT (Thin-Film-Transistor) Color Liquid Crystal Display Module

NHD-	Newhaven Display
4.3-	4.3" Diagonal
480272-	480xRGBx272 Pixels
EF-	Model
A-	Built-in Driver / No Controller
S-	Sunlight Readable
X-	TFT
N-	TN, Wide Temperature
#-	<b>RoHS Compliant</b>
CTP-	Capacitive Touch Panel with Controller

**Newhaven Display International, Inc.**

2661 Galvin Ct.

Elgin IL, 60124

Ph: 847-844-8795

Fax: 847-844-8796

[www.newhavendisplay.com](http://www.newhavendisplay.com)

[nhtech@newhavendisplay.com](mailto:nhtech@newhavendisplay.com)

[nhsales@newhavendisplay.com](mailto:nhsales@newhavendisplay.com)

## Document Revision History

Revision	Date	Description	Changed by
0	10/6/15	Initial Release	SB
1	1/10/17	Mechanical Drawing, Electrical & Optical Char. Updated	SB
2	3/11/17	Driver IC Updated	SB

## Functions and Features

- 480xRGBx272 resolution, up to 16.7M colors
- 16-LED backlight
- 24 bit RGB interface
- Sunlight Readable
- Capacitive touch panel with controller
  - 5 point multi-touch input
  - Gesture input
    - Zoom In/Out
    - Swipe Up/Down/Left/Right

# Mechanical Drawing

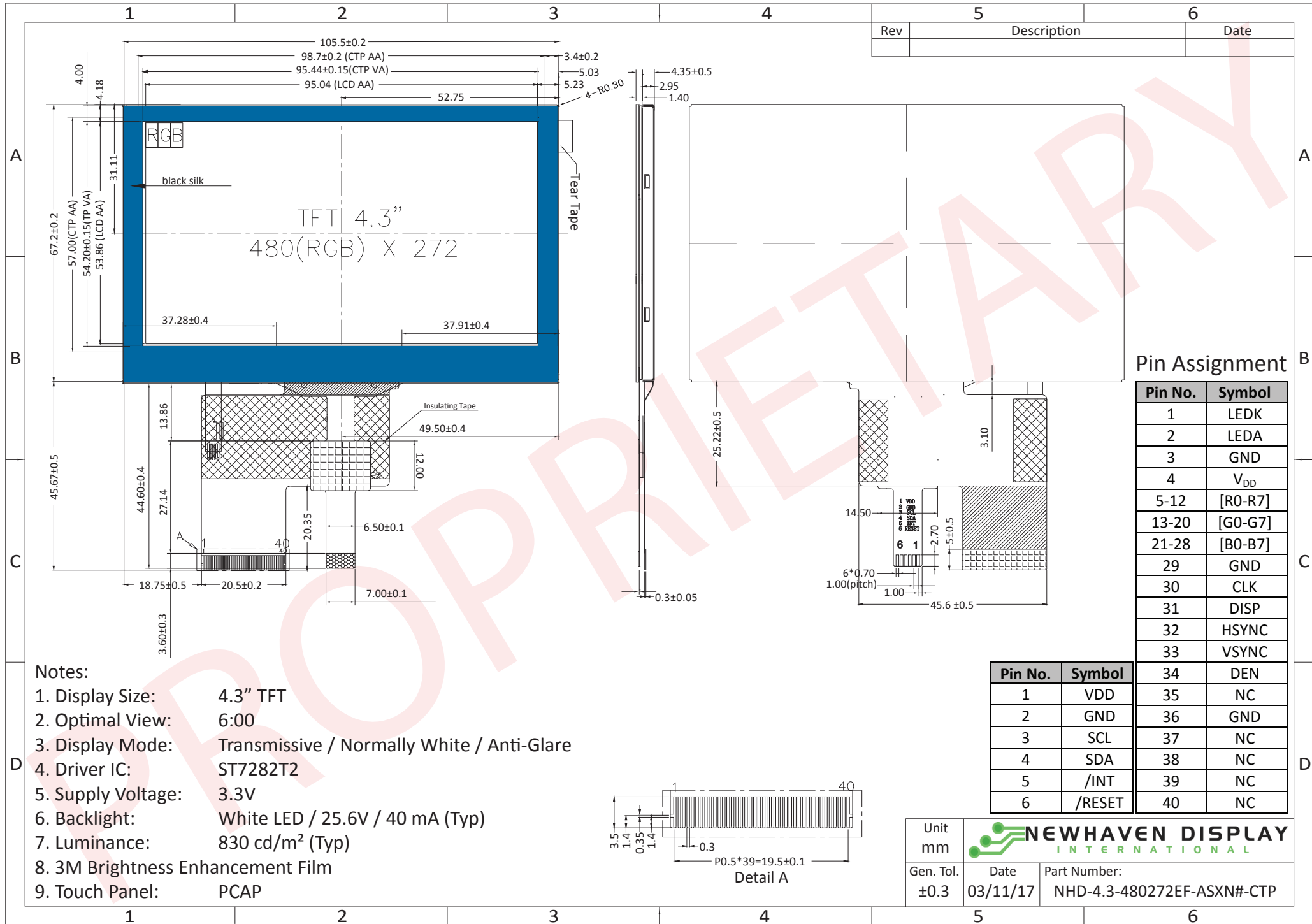

The information contained herein is the exclusive property of Newhaven Display International, Inc. and shall not be copied, reproduced, and/or disclosed in any format without permission.

## Pin Description

### TFT:

Pin No.	Symbol	External Connection	Function Description
1	LED-	Power Supply	Backlight Cathode (Ground)
2	LED+	Power Supply	Backlight Anode (40mA @ 25.6V)
3	GND	Power Supply	Ground
4	VDD	Power Supply	Supply Voltage for LCD and logic (3.3V)
5-12	[R0-R7]	MPU	Red Data signals
13-20	[G0-G7]	MPU	Green Data signals
21-28	[B0-B7]	MPU	Blue Data signals
29	GND	Power Supply	Ground
30	CLK	MPU	Data sample Clock signal
31	DISP	MPU	Display ON/OFF signal
32	HSYNC	MPU	Line synchronization signal
33	VSYNC	MPU	Frame synchronization signal
34	DE	MPU	Data Enable signal
35	NC	-	No Connect
36	GND	Power Supply	Ground
37	NC	-	No Connect
38	NC	-	No Connect
39	NC	-	No Connect
40	NC	-	No Connect

**Recommended LCD connector:** 0.5mm pitch 40-Conductor FFC. Molex p/n: 54104-4033

**Backlight connector:** on LCD connector

**Mates with:** ---

### Capacitive Touch Panel:

Pin No.	Symbol	External Connection	Function Description
1	VDD	Power Supply	Power supply for logic (3.3V)
2	GND	Power Supply	Ground
3	SCL	MPU	Serial I2C Clock (Requires pull-up resistor)
4	SDA	MPU	Serial I2C Data (Requires pull-up resistor)
5	/INT	MPU	Interrupt signal from T.P. module to host (Requires pull-up resistor)
6	/RESET	MPU	Active LOW Reset signal

**Recommended connector:** 1.0mm pitch 6-Conductor FFC. Molex p/n: 52271-0679

## Electrical Characteristics

### TFT:

Item	Symbol	Condition	Min.	Typ.	Max.	Unit
Operating Temperature Range	T <sub>OP</sub>	Absolute Max	-20	-	+70	°C
Storage Temperature Range	T <sub>ST</sub>	Absolute Max	-30	-	+80	°C
Supply Voltage	V <sub>DD</sub>	-	3.0	3.3	3.6	V
Supply Current	I <sub>DD</sub>	V <sub>DD</sub> = 3.3V	12	25	50	mA
"H" level input	V <sub>IH</sub>	-	0.8 * V <sub>DD</sub>	-	V <sub>DD</sub>	V
"L" level input	V <sub>IL</sub>	-	GND	-	0.3 * V <sub>DD</sub>	V
"H" level output	V <sub>OH</sub>	-	0.9 * V <sub>DD</sub>	-	V <sub>DD</sub>	V
"L" level output	V <sub>OL</sub>	-	GND	-	0.1 * V <sub>DD</sub>	V
Backlight Supply Current	I <sub>LED</sub>	-	-	40	50	mA
Backlight Supply Voltage	V <sub>LED</sub>	I <sub>LED</sub> = 40 mA	22.4	25.6	2	V
Backlight Lifetime*	-	I <sub>LED</sub> = 40mA T <sub>OP</sub> = 25°C	20,000	50,000	-	Hrs.

\*Backlight lifetime is rated as Hours until **half-brightness**, under normal operating conditions. The LED of the backlight is driven by current drain; drive voltage is for reference only. Drive voltage must be selected to ensure backlight current drain is below MAX level stated.

### Capacitive Touch Panel:

Item	Symbol	Condition	Min.	Typ.	Max.	Unit
Operating Temperature Range	T <sub>OP</sub>	Absolute Max	-20	-	+70	°C
Storage Temperature Range	T <sub>ST</sub>	Absolute Max	-30	-	+80	°C
Supply Voltage	V <sub>DD</sub>	-	3.0	3.3	3.6	V
Supply Current (Operating)	I <sub>DD</sub>	V <sub>DD</sub> = 3.3V	-	6.0	-	mA
Supply Current (Hibernate)	I <sub>DD</sub>	T <sub>OP</sub> = 25°C	-	1.0	-	µA
"H" level input	V <sub>IH</sub>	-	0.7 * V <sub>DD</sub>	-	V <sub>DD</sub>	V
"L" level input	V <sub>IL</sub>	-	GND	-	0.3 * V <sub>DD</sub>	V
"H" level output	V <sub>OH</sub>	-	0.7 * V <sub>DD</sub>	-	V <sub>DD</sub>	V
"L" level output	V <sub>OL</sub>	-	GND	-	0.3 * V <sub>DD</sub>	V

## Optical Characteristics

Item	Symbol	Condition	Min.	Typ.	Max.	Unit	
Optimal Viewing Angles	Top	Cr ≥ 10	-	55	-	°	
	Bottom		-	75	-	°	
	Left		-	75	-	°	
	Right		-	75	-	°	
Contrast Ratio	CR	-	400	500	-	-	
Luminance	L <sub>V</sub>	-	660	830	-	cd/m <sup>2</sup>	
Response Time	Rise + Fall	T <sub>R</sub> + T <sub>F</sub>	T <sub>OP</sub> = 25°C	-	25	30	ms
Chromaticity	Red	X <sub>R</sub>	-	0.531	0.581	0.631	-
		Y <sub>R</sub>	-	0.300	0.350	0.400	-
	Green	X <sub>G</sub>	-	0.263	0.313	0.363	-
		Y <sub>G</sub>	-	0.568	0.618	0.668	-
	Blue	X <sub>B</sub>	-	0.093	0.143	0.193	-
		Y <sub>B</sub>	-	0.050	0.100	0.150	-
White	X <sub>W</sub>	-	0.233	0.283	0.333	-	
	Y <sub>W</sub>	-	0.286	0.336	0.386	-	

## Capacitive Touch Panel Material Characteristics

Property	Requirement	Unit
IC	FT5306DE4	-
ITO Glass Thickness	0.55	mm
Surface Hardness	≥6	H
Transparency	83% ± 5%	-
Operating Humidity	20~90	RH
Storage Humidity	20~90	RH

## Driver/Controller Information

### TFT:

Built-in Sitronix ST7282T2 Driver.

Please download specification at <http://www.newhavendisplay.com/appnotes/datasheets/LCDs/ST7282T2.pdf>

### Capacitive Touch Panel:

Built-in FocalTech FT5306

Please download specification at [http://www.newhavendisplay.com/app\\_notes/FT5x06.pdf](http://www.newhavendisplay.com/app_notes/FT5x06.pdf)

# Capacitive Touch Panel Registers

Address	Name	B7	B6	B5	B4	B3	B2	B1	B0	Access		
00h	DEVICE_MODE	Device Mode [2..0]									R/W	
01h	GEST_ID	Gesture ID [7..0]								R		
02h	TD_STATUS						Touch Points [3..0]					R
03h	TOUCH1_XH	Event Flag			1st Touch X Position MSB [11..8]					R		
04h	TOUCH1_XL	1st Touch X Position LSB [7..0]								R		
05h	TOUCH1_YH	Touch ID [3..0]			1st Touch Y Position MSB [11..8]					R		
06h	TOUCH1_YL	1st Touch Y Position LSB [7..0]								R		
07h										R		
08h										R		
09h	TOUCH2_XH	Event Flag			2nd Touch X Position MSB [11..8]					R		
0Ah	TOUCH2_XL	2nd Touch X Position LSB [7..0]								R		
0Bh	TOUCH2_YH	Touch ID [3..0]			2nd Touch Y Position MSB [11..8]					R		
0Ch	TOUCH2_YL	2nd Touch Y Position LSB [7..0]								R		
0Dh										R		
0Eh										R		
0Fh	TOUCH3_XH	Event Flag			3rd Touch X Position MSB [11..8]					R		
10h	TOUCH3_XL	3rd Touch X Position LSB [7..0]								R		
11h	TOUCH3_YH	Touch ID [3..0]			3rd Touch Y Position MSB [11..8]					R		
12h	TOUCH3_YL	3rd Touch Y Position LSB [7..0]								R		
13h										R		
14h										R		
15h	TOUCH4_XH	Event Flag			4th Touch X Position MSB [11..8]					R		
16h	TOUCH4_XL	4th Touch X Position LSB [7..0]								R		
17h	TOUCH4_YH	Touch ID [3..0]			4th Touch Y Position MSB [11..8]					R		
18h	TOUCH4_YL	4th Touch Y Position LSB [7..0]								R		
19h										R		
1Ah										R		
1Bh	TOUCH5_XH	Event Flag			5th Touch X Position MSB [11..8]					R		
1Ch	TOUCH5_XL	5th Touch X Position LSB [7..0]								R		
1Dh	TOUCH5_YH	Touch ID [3..0]			5th Touch Y Position MSB [11..8]					R		
1Eh	TOUCH5_YL	5th Touch Y Position LSB [7..0]								R		
1Fh										R		

Address	Name	B7	B6	B5	B4	B3	B2	B1	B0	Access	
80h	ID_G_THGROUP	valid touching detect threshold								R/W	
81h	ID_G_THPEAK	valid touching peak detect threshold								R/W	
82h	ID_G_THCAL	the threshold when calculating the focus of touching								R/W	
83h	ID_G_THWATER	the threshold when there is surface water								R/W	
84h	ID_G_TEMP	the threshold of temperature compensation								R/W	
85h	ID_G_THDIFF	the threshold whether the coordinate is different from original								R/W	
86h	ID_G_CTRL						Power Control Mode [1..0]				R/W
87h	ID_G_TIME_ENTER_MONITOR	the timer for entering monitor status								R/W	
88h	ID_G_PERIODACTIVE						Period Active [3..0]				R/W
89h	ID_G_PERIODMONITOR	the timer of entering idle when in monitor status								R/W	
A0h	ID_G_AUTO_CLB_MODE	auto calibration mode								R/W	
A1h	ID_G_LIB_VERSION_H	Firmware Library Version H byte								R	
A2h	ID_G_LIB_VERSION_L	Firmware Library Version L byte								R	
A3h	ID_G_CIPHER	Chip vendor ID								R	
A4h	ID_G_MODE	the interrupt status to host								R	
A5h	ID_G_PMODE	Power Consume Mode									
A6h	ID_G_FIRMID	Firmware ID								R	
A7h	ID_G_STATE	Running State									
A8h	ID_G_FT5201ID	CTPM Vendor ID								R	
A9h	ID_G_ERR	Error Code								R	
AAh	ID_G_CLB	Configure TP module during calibration in Test Mode								R/W	
FEh	LOG_MSG_CNT	The log MSG count								R	
FFh	LOG_CUR_CHA	Current character of log message								R	

NOTE: Registers 80h – AFh have been configured for optimum settings and do not need to be modified.



Register No	Register Name	Bits	Value	Description
00h	Device Mode	[2:0]	000b 100b 001b	Normal Operating Mode Test Mode - read raw data (reserved) System Information Mode (reserved)
01h	Gesture ID	[7:0]	48h 49h 00h	Zoom In Zoom Out No Gesture
02h	Touch Points	[3:0]	000b 001b 010b 011b 100b 101b	0 touch points detected 1 touch point detected 2 touch points detected 3 touch points detected 4 touch points detected 5 touch points detected
03h	Touch 1 Event Flag	[7:6]	00b 01b 10b 11b	Put Down Put Up Contact Reserved
03h	TOUCH1_XH	[3:0]	0h - 1h	Upper 4 bits of X touch coordinate
04h	TOUCH1_XL	[7:0]	00h - FFh	Lower 8 bits of X touch coordinate
05h	TOUCH1_YH	[3:0]	0h - 1h	Upper 4 bits of Y touch coordinate
06h	TOUCH1_YL	[7:0]	00h - FFh	Lower 8 bits of Y touch coordinate
09h	Touch 2 Event Flag	[7:6]	00b 01b 10b 11b	Put Down Put Up Contact Reserved
09h	TOUCH2_XH	[3:0]	0h - 1h	Upper 4 bits of X touch coordinate
0Ah	TOUCH2_XL	[7:0]	00h - FFh	Lower 8 bits of X touch coordinate
0Bh	TOUCH2_YH	[3:0]	0h - 1h	Upper 4 bits of Y touch coordinate
0Ch	TOUCH2_YL	[7:0]	00h - FFh	Lower 8 bits of Y touch coordinate
0Fh	Touch 3 Event Flag	[7:6]	00b 01b 10b 11b	Put Down Put Up Contact Reserved
0Fh	TOUCH3_XH	[3:0]	0h - 1h	Upper 4 bits of X touch coordinate
10h	TOUCH3_XL	[7:0]	00h - FFh	Lower 8 bits of X touch coordinate
11h	TOUCH3_YH	[3:0]	0h - 1h	Upper 4 bits of Y touch coordinate
12h	TOUCH3_YL	[7:0]	00h - FFh	Lower 8 bits of Y touch coordinate
15h	Touch 4 Event Flag	[7:6]	00b 01b 10b 11b	Put Down Put Up Contact Reserved
15h	TOUCH4_XH	[3:0]	0h - 1h	Upper 4 bits of X touch coordinate
16h	TOUCH4_XL	[7:0]	00h - FFh	Lower 8 bits of X touch coordinate
17h	TOUCH4_YH	[3:0]	0h - 1h	Upper 4 bits of Y touch coordinate
18h	TOUCH4_YL	[7:0]	00h - FFh	Lower 8 bits of Y touch coordinate

Register No	Register Name	Bits	Value	Description
1Bh	Touch 5 Event Flag	[7:6]	00b 01b 10b 11b	Put Down Put Up Contact Reserved
1Bh	TOUCH5_XH	[3:0]	0h - 1h	Upper 4 bits of X touch coordinate
1Ch	TOUCH5_XL	[7:0]	00h - FFh	Lower 8 bits of X touch coordinate
1Dh	TOUCH5_YH	[3:0]	0h - 1h	Upper 4 bits of Y touch coordinate
1Eh	TOUCH5_YL	[7:0]	00h - FFh	Lower 8 bits of Y touch coordinate
80h	ID_G_THGROUP	[7:0]	00h - FFh	Valid touching detect threshold Actual value will be 4 times register's value Recommended: 46h
81h	ID_G_THPEAK	[7:0]	00h - FFh	valid touching peak detect threshold Recommended: 3Ch
82h	ID_G_THCAL	[7:0]	00h - FFh	Touch focus threshold Recommended: 1Dh
83h	ID_G_THWATER	[7:0]	00h - FFh	threshold when there is surface water Recommended: D3h
84h	ID_G_THTEMP	[7:0]	00h - FFh	threshold of temperature compensation Recommended: EBh
85h	ID_G_THDIFF	[7:0]	00h - FFh	Touch difference threshold Actual value is 32 times the register's value Recommended: A0h
86h	ID_G_CTRL	[1:0]	00h 01h	Power Control Mode: Not Auto Jump Power Control Mode: Auto Jump
87h	ID_G_TIME_ENTER_MONITOR	[7:0]	00h-FFh	Delay to enter 'Monitor' status (s) Recommended: C8h
88h	ID_G_PERIODACTIVE	[3:0]	3h-Eh	Period of 'Active' status (ms) Recommended: 6h
89h	ID_G_PERIODMONITOR	[7:0]	1Eh-FFh	Timer to enter 'idle' when in 'Monitor' (ms) Recommended: 28h
A0h	ID_G_AUTO_CLB_MODE	[7:0]	00h FFh	Auto calibration mode: Enable auto calibration Auto calibration mode: Disable auto calibration
A1h	ID_G_LIB_VERSION_H	[7:0]	30h	Firmware Library Version H byte
A2h	ID_G_LIB_VERSION_L	[7:0]	01h	Firmware Library Version L byte
A3h	ID_G_CIPHER	[7:0]	55h	Chip vendor ID
A4h	ID_G_MODE	[0:0]	00h 01h	Interrupt status: Enable interrupt to host Interrupt status: Disable interrupt to host
A5h	ID_G_PMODE	[1:0]	00h 01h 03h	'Active' Mode 'Monitor' Mode 'Hibernate' Mode
A6h	ID_G_FIRMID	[7:0]	08h	Firmware ID
A7h	ID_G_STATE	[7:0]	00h 01h 02h 03h 04h	Running State: Configure Running State: Work Running State: Calibration Running State: Factory Running State: Auto-calibration
A8h	ID_G_FT5201ID	[7:0]	79h	CTPM Vendor's Chip ID
A9h	ID_G_ERR	[7:0]	00h 03h 05h 1Ah	Error Code: OK Error Code: Chip register writing inconsistent with reading Error Code: Chip start fail Error Code: Calibration match fail

# Timing Characteristics – TFT Display

## Timing Characteristics

### Parallel RGB input timing requirement

Item		Symbol	Min.	Typ.	Max.	Unit	Remark
DCLK Frequency		FCLK	9	12	15	MHz	
DCLK Period		TCLK	10	50	-	μS	R=10KΩ, 1μF
HSYNC	Period Time	Th	485	525	532	DCLK	
	Display Period	Thdisp	-	480	-	DCLK	
	Back Porch	Thbp	3	43	50	DCLK	By H_Blanking Setting
	Front Porch	Thfp	2	2	2	DCLK	
	Pulse Width	Thw	1	1	1	DCLK	
VSYNC	Period Time	Tv	275	285	303	H	
	Display Period	Tvdisp	-	272	-	H	
	Back Porch	Tvbp	2	12	30	H	By V_Blanking Setting
	Front Porch	Tvfp	1	1	1	H	
	Pulse Width	Tvw	1	1	1	H	

- SYNC Mode Timing

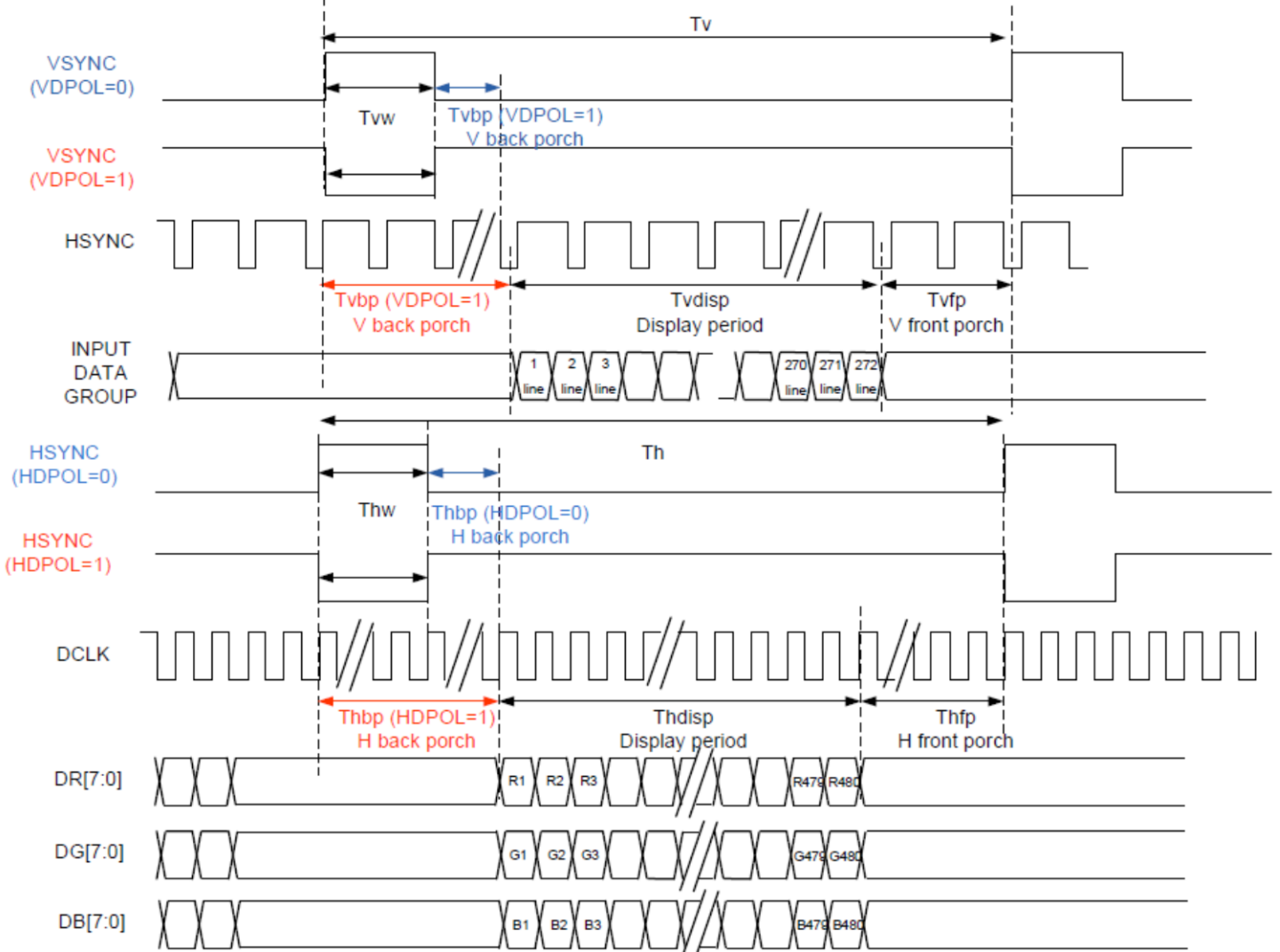

- SYNC-DE Mode Timing

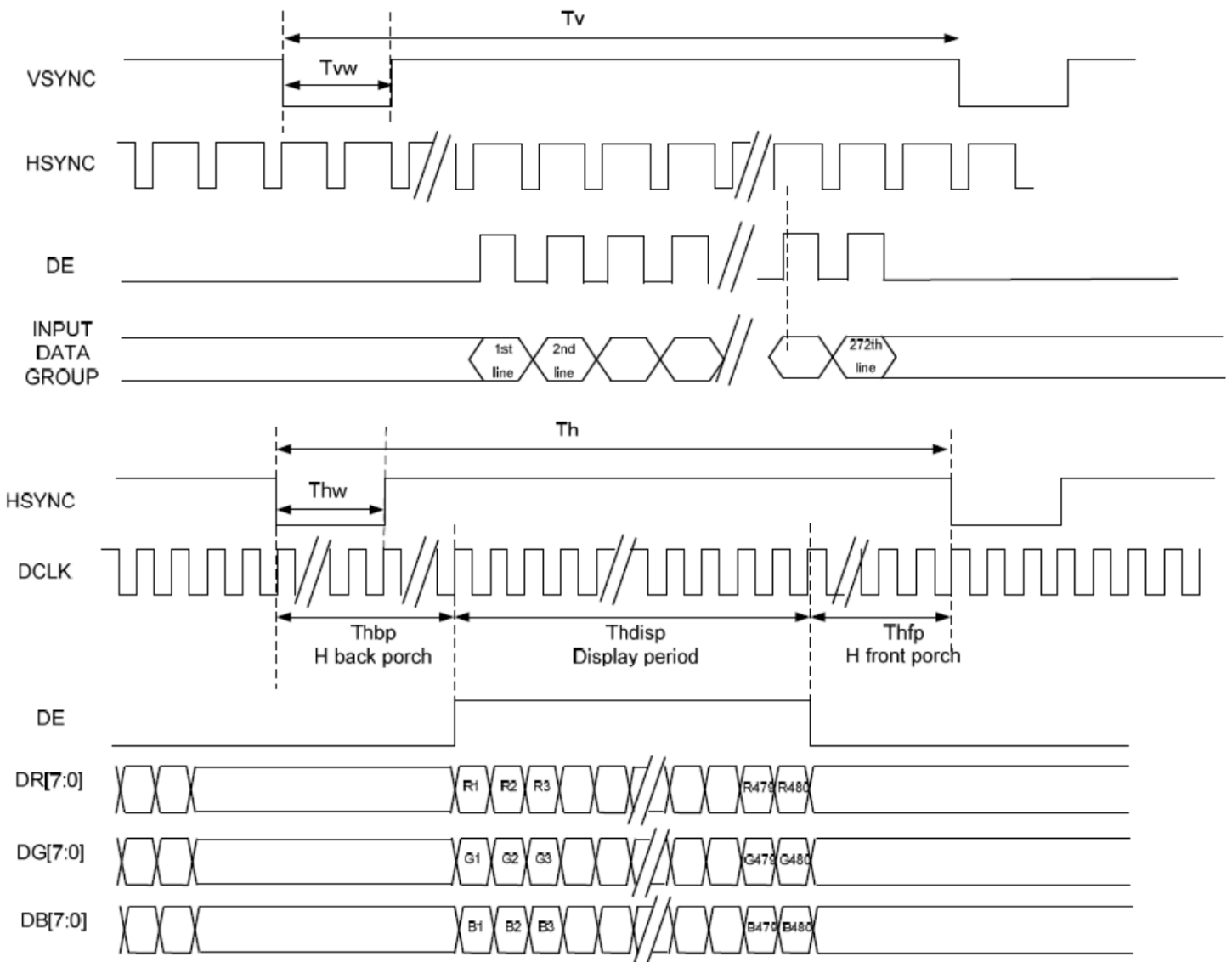

## Input setup timing requirement

Item	Symbol	Min.	Typ.	Max.	Unit	Conditions
System Operation Timing						
V <sub>DD</sub> Power Source Slew Time	TPOR	-	-	20	ms	From 0V to 99% V <sub>DD</sub>
GRB Pulse Width	tRSTW	10	50	-	μS	R=10KΩ, 1μF
Input / Output Timing						
CLK pulse Duty	TCW	40	50	60	%	
Hsync Width	Thw	1	-	-	DCLK	
Hsync Period	Th	50	60	65	μS	
Vsync setup time	Tvst	12	-	-	ns	
Vsync hold time	Tvhd	12	-	-	ns	
Hsync setup time	Thst	12	-	-	ns	
Hsync hold time	Thhd	12	-	-	ns	
Data setup time	Tdsu	12	-	-	ns	
Data hold time	Tdhd	12	-	-	ns	
SD output stable time	Tst	-	-	12	μS	Output settled within +20mV Loading = 6.8k+28.2pF
GD output rise and fall time	Tgst	-	-	6	μS	Output settled (5%~95%) Loading = 4.7k+29.8pF

### - Clock And Data Input Timing Diagram

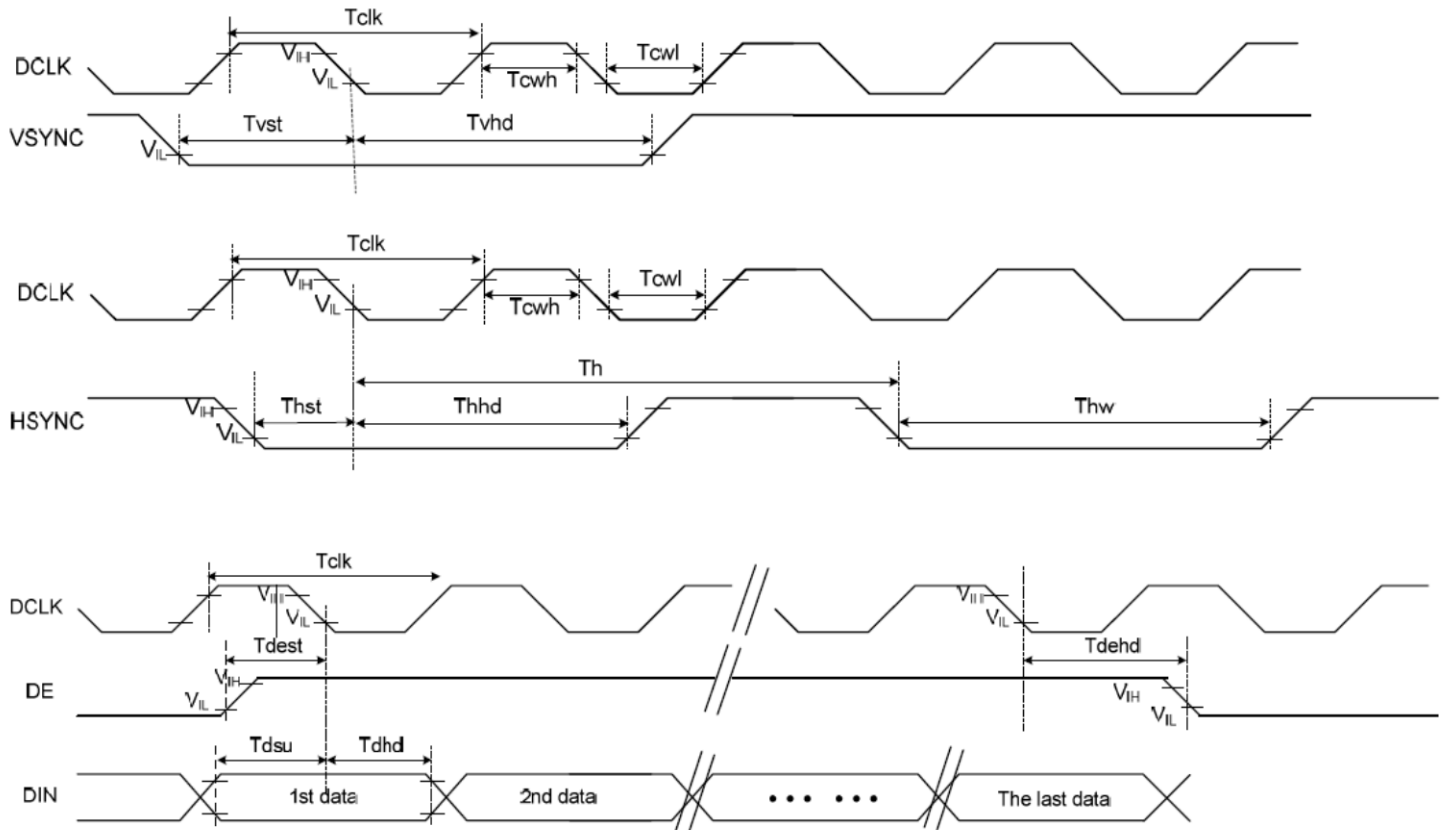

# Power On/Off Sequence

## - Power On Sequence

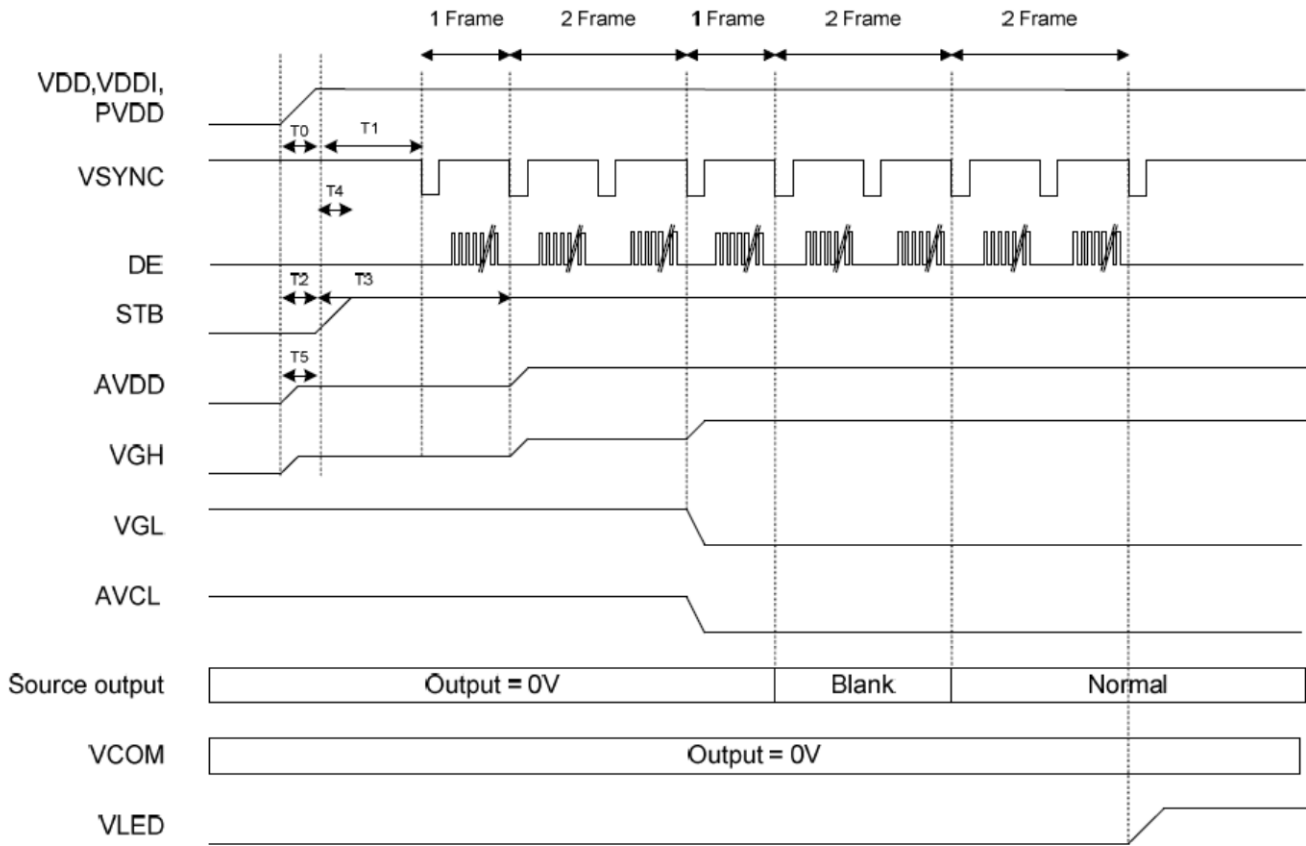

	Description	Min. Time
T0	Determined by the external power	
T1	Time from stable VDD, VDDI, PVDD set-up to the first VSYNC	T1=0
T2	Time from AVDD=0V to AVDD=3.3V	T2=T0
T3	Time from AVDD=3.3V to AVDD=6.0V	T3=T1+ (1*Frame)
T4	Time from stable VDD, VDDI, PVDD set-up to DISP asserted	T4=0
T5	Time from VGH=0V to VGH=3.3V	T5=T0

- **Power Off Sequence**

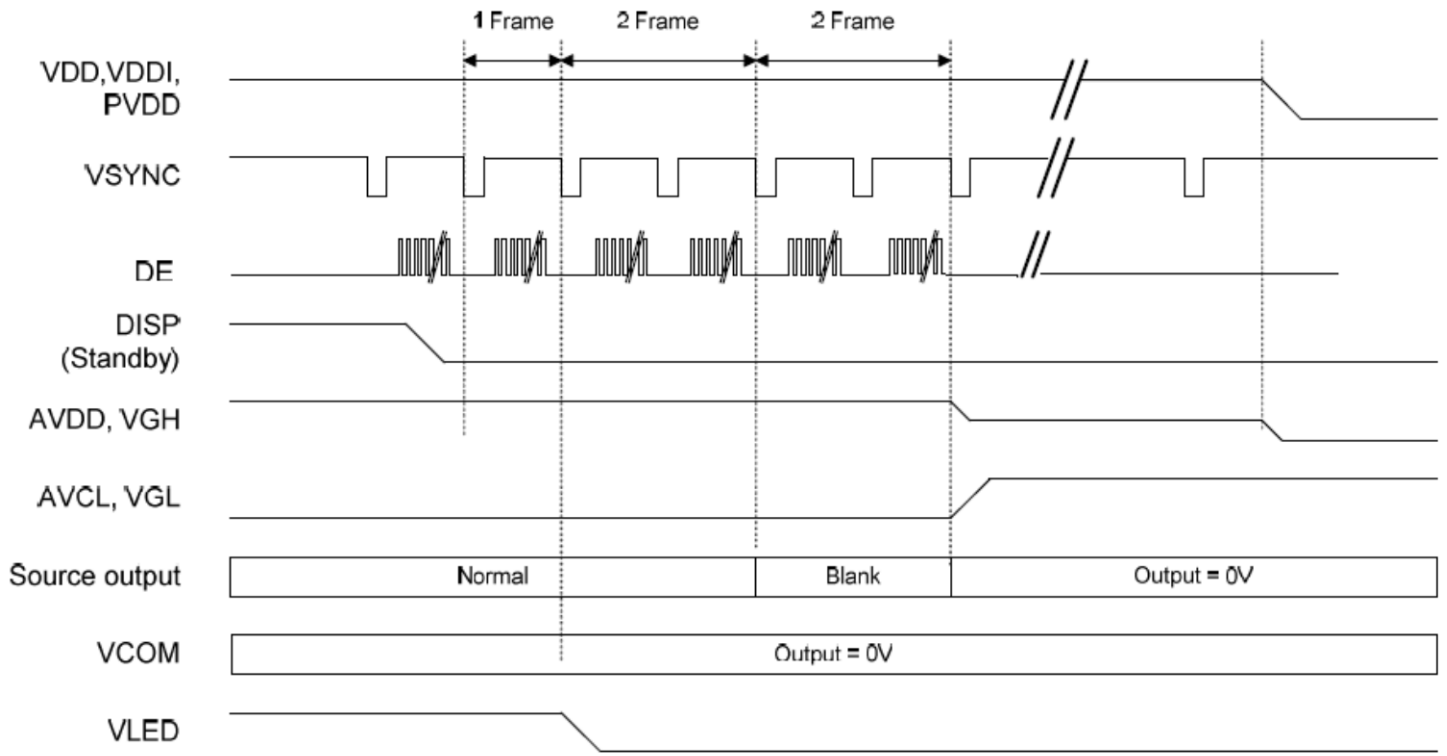



# Timing Characteristics – Capacitive Touch Panel

## Data Transfer Format

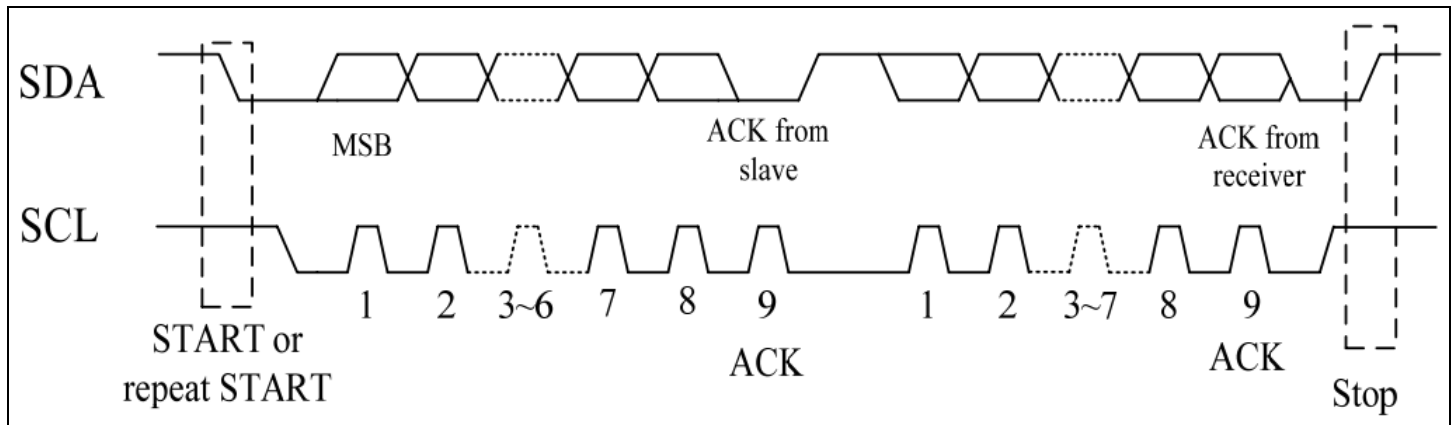

Parameter	Unit	Min	Max
SCL frequency	KHz	0	400
Bus free time between a STOP and START condition	us	4.7	\
Hold time (repeated) START condition	us	4.0	\
Data setup time	ns	250	\
Setup time for a repeated START condition	us	4.7	\
Setup Time for STOP condition	us	4.0	\

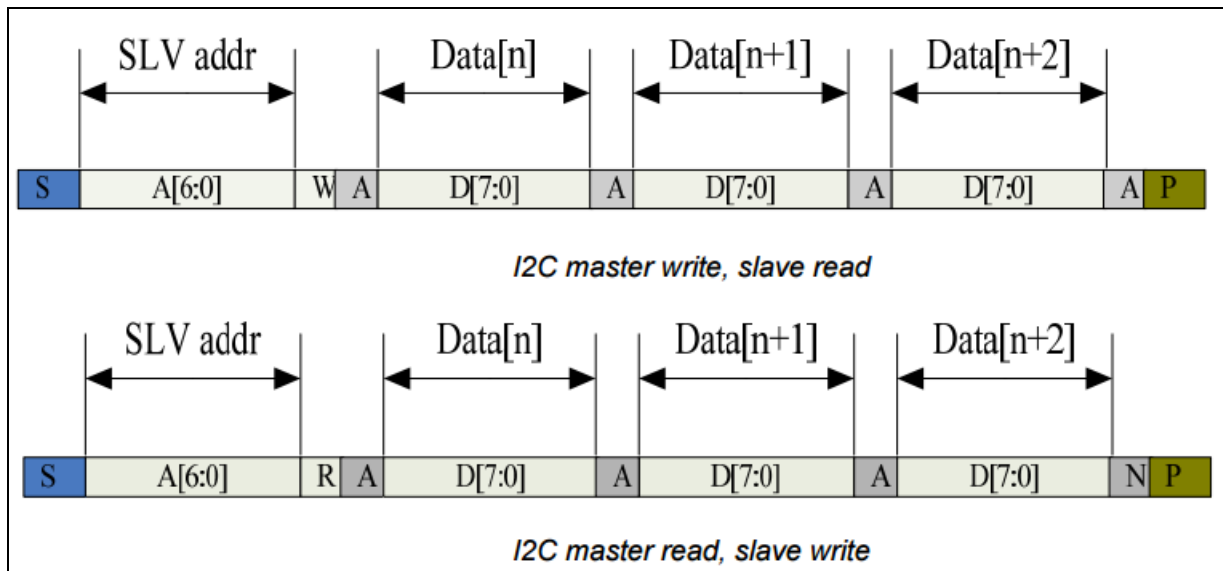

### Power ON Sequence

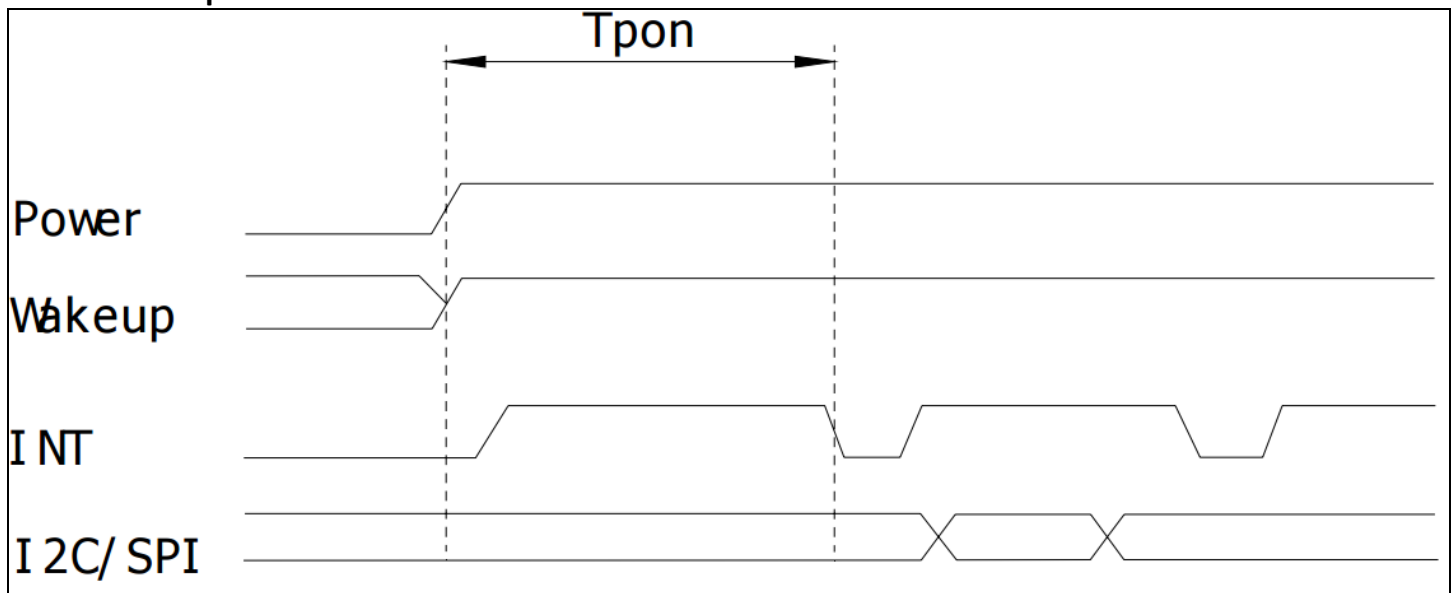

### Reset Sequence

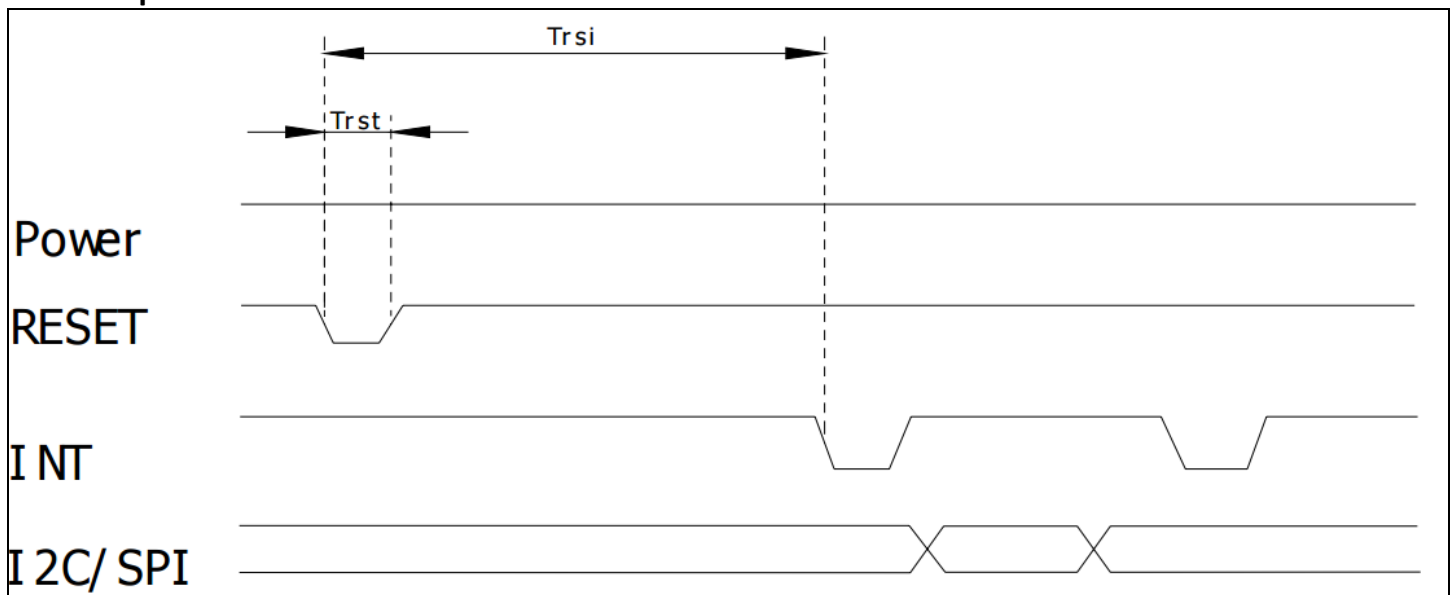

Parameter	Description	Min	Max	Units
$T_{ris}$	Rise time from 0.1VDD to 0.9VDD	--	10	ms
$T_{pon}$	Time of starting to report point after powering on	300	--	ms
$T_{rsi}$	Time of starting to report point after resetting	300	--	ms
$T_{rst}$	Reset time	5	--	ms
$T_{wai}$	Time of starting to report point after waking	300	--	ms
$T_{wak}$	Wake up time	5	--	ms

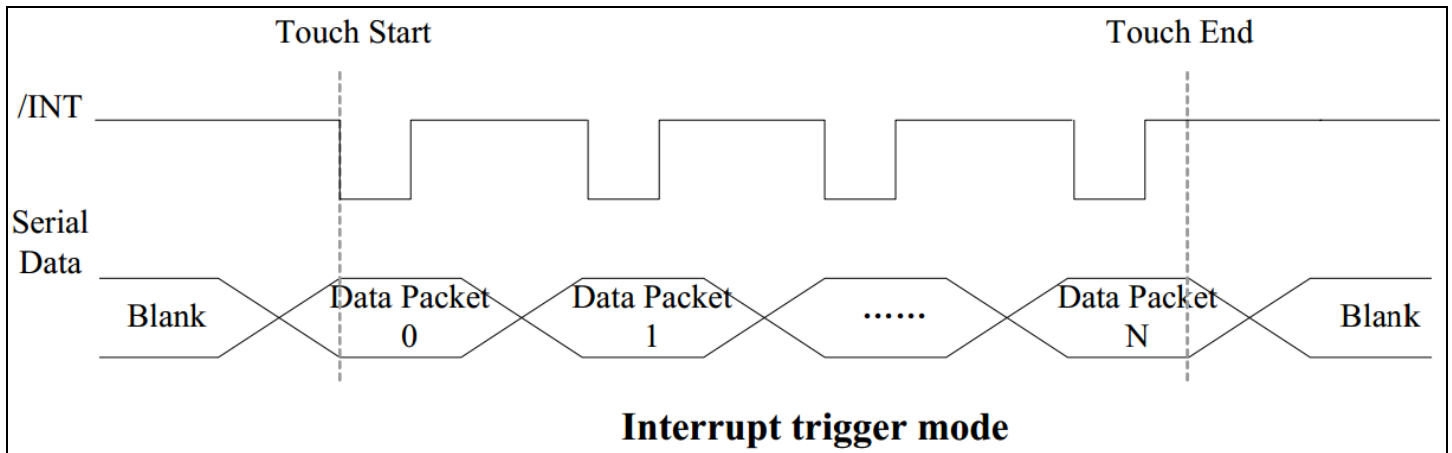

### Sample code to read touch data:

```

i2c_start();
i2c_tx(0x70);           //Slave Address (Write)
i2c_tx(0x00);          //Start reading address
i2c_stop();

i2c_start();
i2c_tx(0x71);           //Slave Address (Read)
for(i=0x00;i<0x1F;i++)
{touchdata_buffer[i] = i2c_rx(1);}
i2c_stop();

```

### Sample code to overwrite default register values:

```

i2c_start();
i2c_tx(0x70);           //Slave Address (Write)
i2c_tx(0xA4);           //ID_G_Mode
i2c_tx(0x01);           //Disable interrupt status to host
i2c_stop();

```

## Quality Information

Test Item	Content of Test	Test Condition	Note
High Temperature storage	Endurance test applying the high storage temperature for a long time.	+80°C , 96 Hrs.	2
Low Temperature storage	Endurance test applying the low storage temperature for a long time.	-30°C , 96 Hrs.	1,2
High Temperature Operation	Endurance test applying the electric stress (voltage & current) and the high thermal stress for a long time.	+70°C , 96 Hrs.	2
Low Temperature Operation	Endurance test applying the electric stress (voltage & current) and the low thermal stress for a long time.	-20°C , 96 Hrs.	1,2
High Temperature / Humidity Operation	Endurance test applying the electric stress (voltage & current) and the high thermal with high humidity stress for a long time.	+50°C , 90% RH , 96 Hrs.	1,2
Thermal Shock resistance	Endurance test applying the electric stress (voltage & current) during a cycle of low and high thermal stress.	-20°C,60min -> 25°C,5min ->70°C,60min = 1 cycle 20 cycles	
Vibration test	Endurance test applying vibration to simulate transportation and use.	10-50Hz , 15mm amplitude. 30 Min. Each Direction X,Y,Z	3
Static electricity test	Endurance test applying electric static discharge.	Air: V <sub>S</sub> =±8KV, Contact: V <sub>S</sub> =±4KV R <sub>S</sub> =330Ω C <sub>S</sub> =150pF 5 Times	

**Note 1:** No condensation to be observed.

**Note 2:** Conducted after 4 hours of storage at 25°C, 0%RH.

**Note 3:** Test performed on product itself, not inside a container.

## Precautions for using LCDs/LCMs

See Precautions at [www.newhavendisplay.com/specs/precautions.pdf](http://www.newhavendisplay.com/specs/precautions.pdf)

## Warranty Information

See Terms & Conditions at [http://www.newhavendisplay.com/index.php?main\\_page=terms](http://www.newhavendisplay.com/index.php?main_page=terms)