

LED09W-LT Series

Line Voltage Dimmable



Electrical Specifications

Input Voltage Range:	120V model: 108-132V Min/Max 230V model: 208-300V Min/Max
Frequency:	50/60 Hz Nom. (47-63 Hz Min/Max)
Power Factor:	≥0.90 @ full load (no dimmer)
Inrush Current:	<10.0 Amps @ 120Vac, cold start 25°C, max load
Input Current (Max):	0.10 Amps @ 120Vac, 60Hz, max load 0.06 Amps @ 230Vac, 60Hz, max load
Maximum Power:	9W
Line Regulation:	± 3%
Load Regulation:	± 5%
THD:	≤20% @ full load (no dimmer)
Output Protection:	Over-Voltage, Over-Current, and Short Circuit Protection with Auto Recovery
Start-up Time:	0.7 sec

Environmental Specifications

Maximum Case Temp.	90°C
Minimum Starting Temp:	-30°C
Storage Temperature:	-40°C to +85°C
Humidity:	5% to 95%
Cooling:	Convection
Vibration Frequency:	5 to 55 Hz/2g, 30 minutes
Sound Rating:	Class A
Impact Resistance:	1g/s
Lifetime:	50,000 hrs @ Tc=68°C (see graph for details)
MTBF:	402,000 Hours @ full load, 40°C ambient conditions per MIL-217F Notice 2
EMC:	FCC 47CFR Part 15 Class B compliant
Weight:	4.5 oz. (128 g)

- Total Power: 9 Watts
- Input Voltage: 120Vac or 230-277Vac Phase Dimming Ranges
- UL Dry & Damp Location Rated
- UL Type HL Rated for Hazardous Locations
- IP66 & NEMA4
- Compatible with Triac (leading edge) and ELV (electronic low voltage; trailing edge) dimmer controls
- Use a dimmer that closely matches the load, just slightly larger. (EX: For best performance, use a 150W rated dimmer for 100W total LED load instead of 600W dimmer.) larger. (EX: For best performance, use a 150W rated dimmer for 100W total LED load instead of 600W dimmer.)



Constant Current LED Drivers

CCR Dimming: <10%-100%, ELV & Triac dimmable drivers

Black Magic Thermal Advantage™ Plastic Housing

230-277Vac Input - ELV & Triac Dimming Models

Model	Output Current (mA ±5%)	Output Voltage Range (Vdc)	Max. Output Power (W)	Typical Efficiency
LED09W230-036-C0250-LT	250	22-36	9	85%
LED09W230-030-C0300-LT	300	18-30	9	85%
LED09W230-028-C0350-LT	350	17-28	9	84%
LED09W230-020-C0450-LT	450	12-20	9	84%
LED09W230-014-C0700-LT	700	8-14	9	83%
LED09W230-012-C0750-LT	750	7-12	9	83%

120Vac Input - ELV & Triac Dimming Models

Model	Output Current (mA ±5%)	Output Voltage Range (Vdc)	Max. Output Power (W)	Typical Efficiency
LED09W120-036-C0250-LT	250	22-36	9	85%
LED09W120-030-C0300-LT	300	18-30	9	85%
LED09W120-028-C0350-LT	350	17-28	9	84%
LED09W120-020-C0450-LT	450	12-20	9	84%
LED09W120-014-C0700-LT	700	8-14	9	83%
LED09W120-012-C0750-LT	750	7-12	9	83%

Class 2: US/Canada

Safety Certification Standard

UL/CUL	UL8750, UL1310 for UL Class 2 & CAN/CSA C22.2 No. 250.13, UL Type HL
CE	EN 61347-1, EN61347-2-13

EMC Standard Notes

EN 55015	Conducted emission
EN 61000-3-2	RFE Field Susceptibility test
EN 61000-3-3	Electrical Fast Transient
EN 61000-4-5	Surge Immunity Test, 2 kV; L-N
Energy Star	ANSI/IEEE C62.41.1-2002 and ANSI/IEEE C62.41.2-2002
FCC, 47 CFR Part 15	Class B



Dimensions

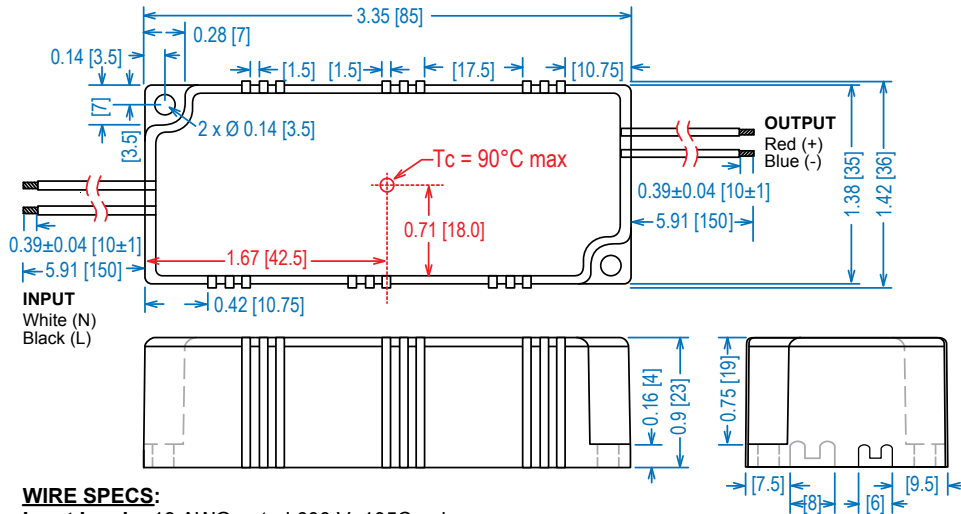

WIRE SPECS:
Input Leads: 18 AWG, rated 600 V, 105C, min.
Output Leads: 18 AWG, rated 300 V, 105C, min.
 All wires are stranded with solder dipped ends.

Power Characteristics

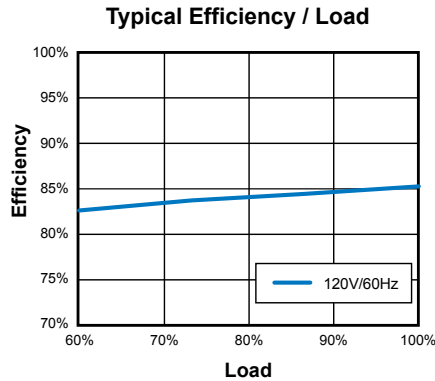
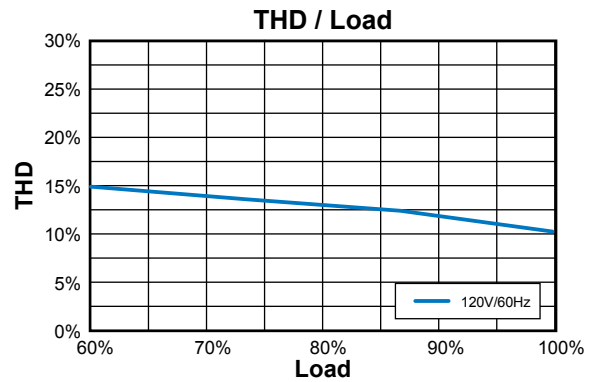
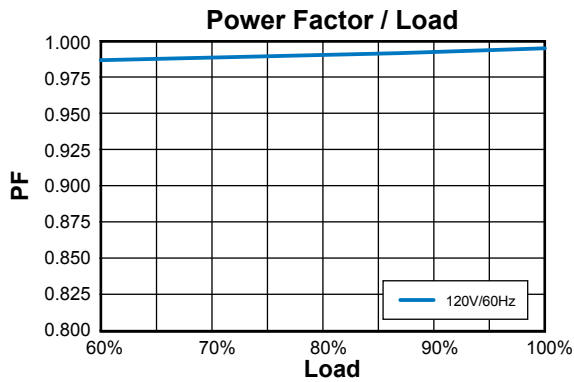

Note: The area under the life-temperature curve represents where the driver has highly reliable operation within specification. Driver performance may drift out of published specifications as the hours of operation exceed the curve at a given temperature. Higher operating temperatures increase the chances of a failure to function. Other electrical, mechanical and environmental factors affect driver lifetime but are not represented in this calculation.