

◆SNAP-IN TYPE PART NUMBER

Rated Voltage		Series		Capacitance		Capacitance Tolerance	Option	Terminal Code		Case Size
Rated Voltage(Vdc)	Code	Cap.(μ F)	Code	Tolerance	Code	Option	Code	Terminal type	Code	D×L
50	50	22	22	$\pm 20\%$	M	PET Sleeve without plate	EFC	Standard terminal	SN	20×25
100	100	560	560	$\pm 10\%$	K	PVC Sleeve without plate	OOE	Keying terminal	EN	22×30
450	450	1000	1000			PVC Sleeve with plate	Blank	Vibration proof terminal	LN	25×35
										30×40
										35×45

Please indicate the above information, when ordering.

Example	200	MXG	820	M	EFC	SN	25×35
	450	USG	330	M	EFC	SN	30×35

◆SNAP-IN TYPE PACKAGING SPECIFICATION

SIZE (mm)	PACKAGE QUANTITY (pcs/box)
$\phi 20$	200
$\phi 22$	200
$\phi 25$	200
$\phi 30$	100
$\phi 35$	100 (Terminal Code BN : 50)
$\phi 40$	50
$\phi 45$	50

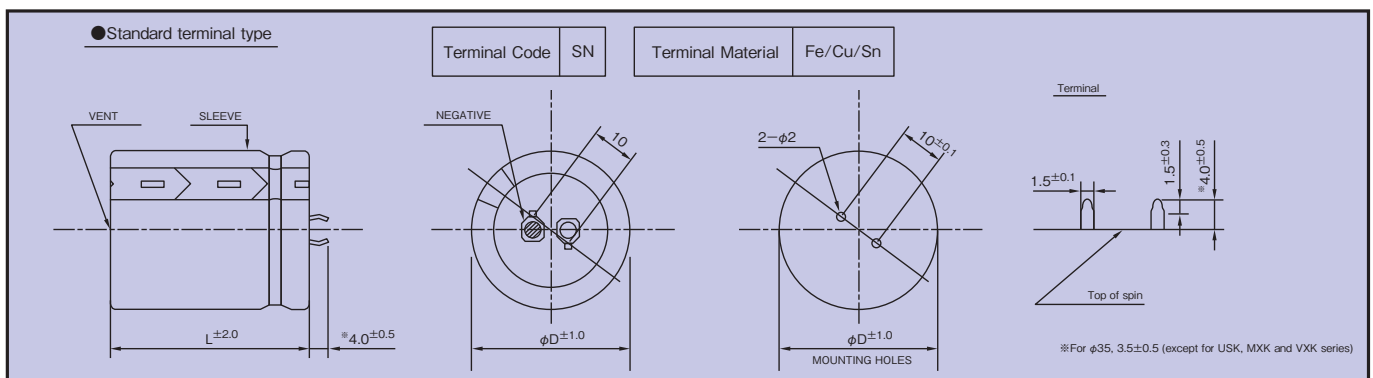
◆TERMINAL TYPE

◆ TERMINAL TYPE

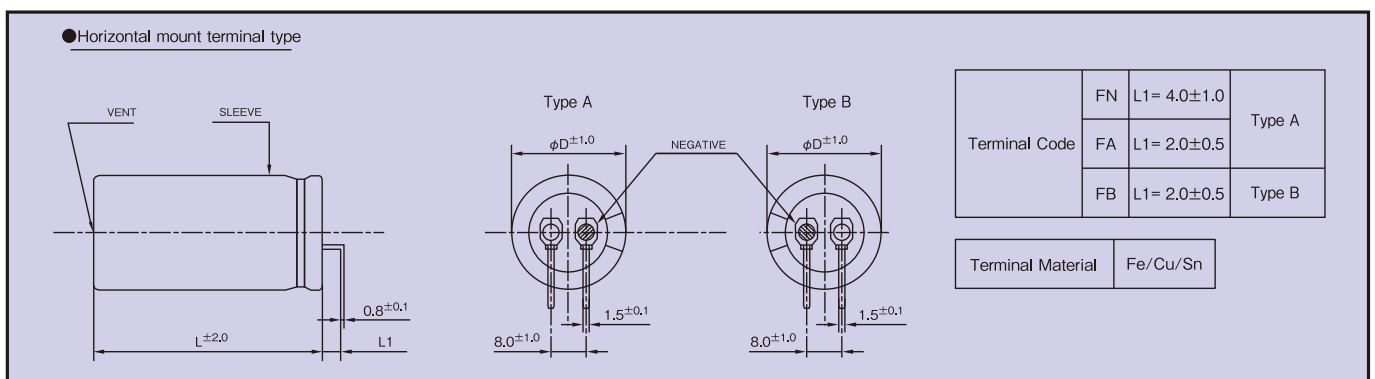
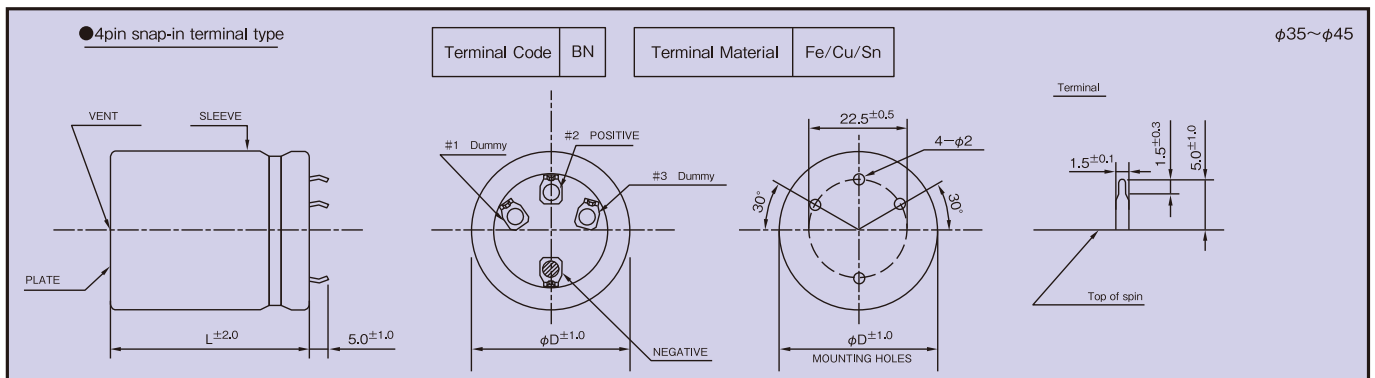
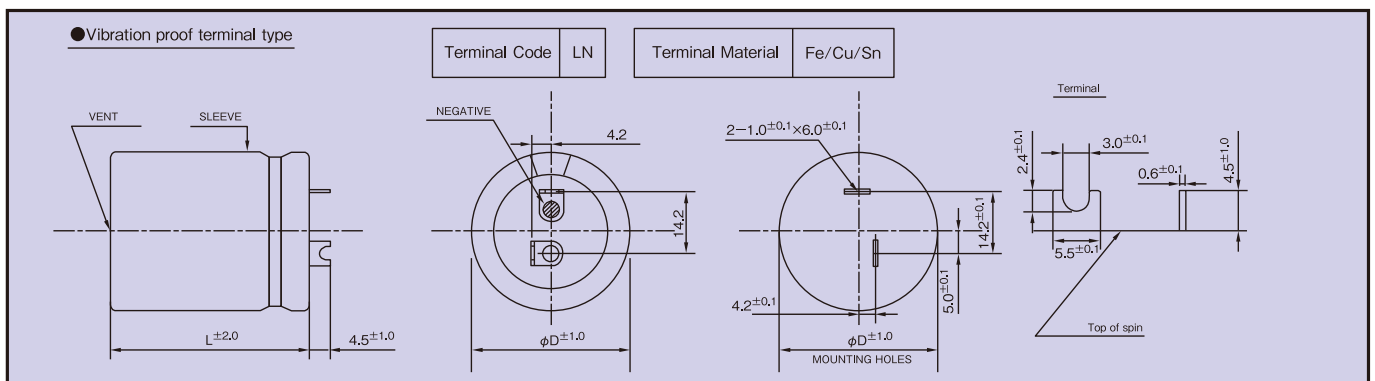
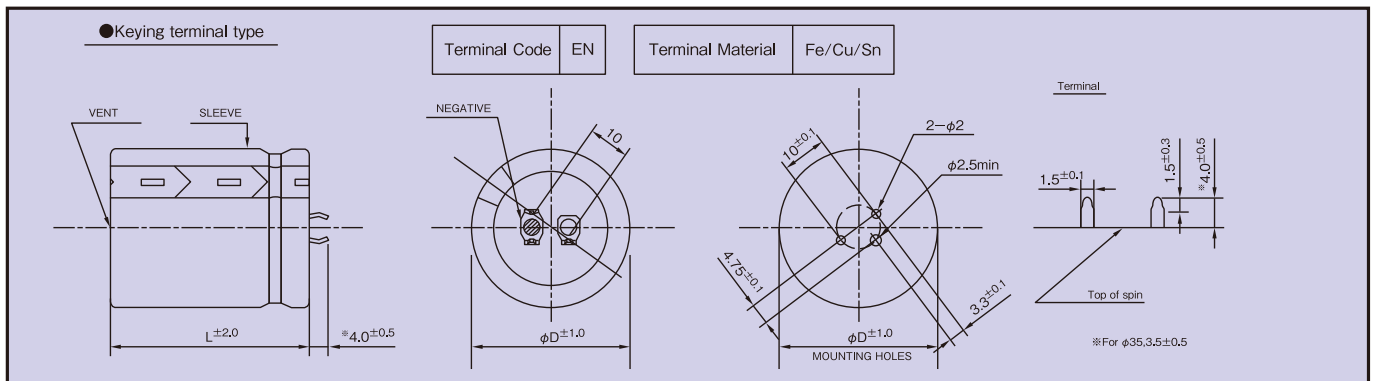

•Please consult us about the other terminal type.

◆SCREW TERMINAL TYPE PART NUMBER

□□□		□□□□		□□□□□		□	□□□	□□	D×L
Rated Voltage		Series		Capacitance		Capacitance Tolerance	Option ※1	Clamp Code ※2	Case Size
↑		↑		↑		↑	↑	↑	↑
Rated Voltage(Vdc)	Code	Cap.(μF)	Code			M±20%	TY: Three stopping clamp		51×138
350	350	5600	5600			K±10%	TI: Two stopping clamp		90×241
450	450	8200	8200				NB: Without stopping clamp		

Please indicate the above information, when ordering.

Example
 ・Y-type clamp(Three stopping clamp) 400 LSU 5600 M TY 77×141

※1 Option:Standard item is blank.

※2 Please contact us for clamp code of stud mounting screw terminal capacitors.

◆SCREW TERMINAL TYPE PACKAGING SPECIFICATION

SIZE(mm)		PACKAGE QUANTITY (pcs/box)	PACKAGE DIMENSIONS W×D×H(mm)	SIZE(mm)		PACKAGE QUANTITY (pcs/box)	PACKAGE DIMENSIONS W×D×H(mm)
φ	L			φ	L		
φ36	~68	60	460×420×255	φ77	~118	10	680×320×215
	69~88	60	460×420×295		119~148	10	680×320×245
	89~118	60	460×420×355		149~198	8	551×340×295
	119~138	60	460×420×395		199~248	6	450×340×345
φ51	~118	30	560×505×215	φ90	~118	10	680×320×215
	119~148	30	560×505×245		119~148	10	680×320×245
φ64	~118	20	525×485×215		149~198	8	551×340×295
	119~149	20	525×485×245		199~248	6	450×340×345
	150~198	10	551×340×295				

<Note>The terminal bolt and clamp is separately supplied and not attached to the product.

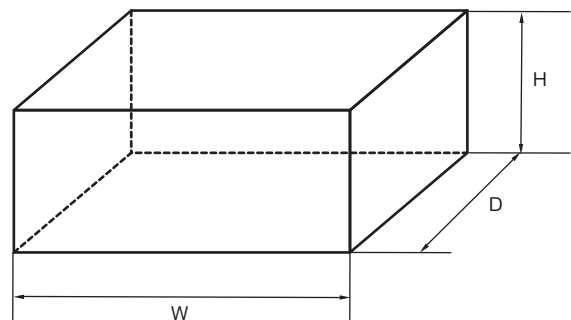

◆ Tightening torque of bolt and Permissible current of terminal

Clamp Bolt	Recommended Tightening torque
M3	0.6 [N·m]
M4	1.3 [N·m]

Terminal	Recommended Tightening torque (Permissible Range)	Permissible Current of Terminal
M5	2.2 (1.5~3.2) [N·m]	60 [A r.m.s.]
M6	3.2 (3.0~3.5) [N·m]	100 [A r.m.s.]
M8	6.3 (5.8~6.8) [N·m]	120 [A r.m.s.]

◆ Accessory for Stud Mounting (Option)

<Nylon cap nut>

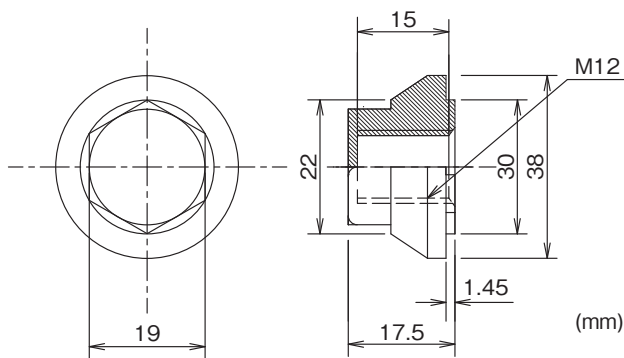

<Nylon shoulder washer>

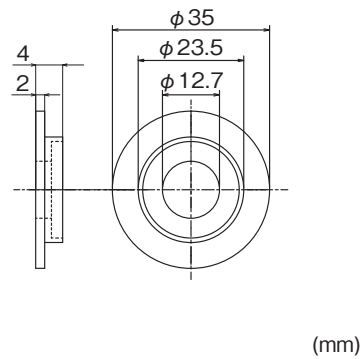
◆ Tightening torque of stud fixing nylon nut

Nylon Nut	Recommended Tightening torque
M12	10.0 [N·m]

◆ Recommended stud mounting method

[Mounting example]

