

SPECIFICATION

PATENT PENDING

Part No: **FXUB68.07.0180C**

Product Name: Minima
Embedded Flexible 4G LTE Wide Band Antenna
700-960MHz, 1700-2700MHz

Features: Flexible Wideband Antenna
Covers worldwide 2G/3G/4G Bands
Isotropic Radiation Pattern
Highest efficiency in smallest size
67.0x58.0x0.2 mm
IPEX 1.37 coaxial cable
RoHS Compliant



1. Introduction

The patent pending Minima FXUB68 flexible antenna has been designed to cover 4G bands in the 700-2700 MHz spectrum, but also optimally covers 2G and 3G. The antenna has a compact, flexible, modern design, with excellent efficiencies on all target bands. The Minima comes standard with 180mm IPEX cable and connector for easy installation and can also be configured for different cable lengths and terminations. The 67x58x0.2mm FXUB68 is made from flexible polymer material, which is ultra-thin, compact and highly efficient across the 3G and 4G bands. It is installed by a simple “peel and stick” process, attaching securely to non-metal surfaces via adhesive backing. The Minima has been designed with excess bandwidth so that performance is not affected by thicker or thinner plastic surfaces to which it is adhered. It enables designers to use only one antenna that covers all cellular communication frequencies in the IoT market.

The Minima antenna has a unique compact geometric design, which has excellent efficiency for its size and isotropic pattern at both low and high bands. This antenna if integrated optimally with enough clearance, can in most cases pass US operator requirements.

The antenna performs well at a reasonable distance, typically 20mm, from a ground and has demonstrated ease of integration into complex end user equipment.

The FXUB68 Minima antenna has a typical efficiency of more than 50% across the low bands and 64% across the high bands. The Minima is designed to be mounted directly onto a plastic or glass cover. It is an ideal choice for any device maker that desires ease of integration and needs to keep manufacturing costs down over the lifetime of a product. Cable and connector can be customized, contact your regional Taoglas sales office for support.

2. Specification

| ELECTRICAL | | | | | | | | |
|-------------------------|------------------|----------|----------|------------|------------|------------|------------|------------|
| Standard | LTE 700 | GSM 850 | GSM 900 | DCS | PCS | UMTS1 | WiFi | LTE 2600 |
| Frequency (MHz) | 698~ 803 | 824~ 894 | 880~ 960 | 1710~ 1880 | 1850~ 1990 | 1920~ 2170 | 2400~ 2480 | 2490~ 2690 |
| Max Return Loss (dB) | -9 | -8 | -7 | -9 | -17 | -13 | -13 | -12 |
| Max VSWR | 2.5 | 2.5 | 3 | 2.5 | 1.5 | 1.5 | 1.5 | 2 |
| Efficiency (%) | 45 | 45 | 45 | 60 | 65 | 65 | 65 | 55 |
| Peak Gain (dBi) | 2 | 2 | 2 | 2 | 2.5 | 2.5 | 3 | 2 |
| Average Gain (dB) | -3.5 | -3.5 | -3.5 | -2.2 | -2 | -2 | -2 | -2.6 |
| Radiation Properties | Omni-directional | | | | | | | |
| Max Input Power (Watts) | 5 | | | | | | | |
| Polarization | Linear | | | | | | | |
| Impedance (Ohms) | 50 Ohms | | | | | | | |
| MECHANICAL | | | | | | | | |
| Dimensions (mm) | 67x58x0.2 mm | | | | | | | |
| Material | Flexible Polymer | | | | | | | |
| Connector and Cable | IPEX and 1.37 mm | | | | | | | |
| ENVIRONMENTAL | | | | | | | | |
| Operation Temperature | -40°C to 85°C | | | | | | | |
| Storage Temperature | -40°C to 85°C | | | | | | | |
| Relative Humidity | 40% to 95% | | | | | | | |
| RoHs Compliant | Yes | | | | | | | |

*Antenna measured on plastic sheet with 1.5mm thickness in "full wrap" configuration.

| LTE BANDS | | | |
|--------------------|--|-------------------------------|----------------|
| Band Number | LTE / LTE- Advanced / WCDMA / HSPA / HSPA+ / TD-SCDMA | | |
| | Uplink | Downlink | Covered |
| 1 | UL: 1920 to 1980 | DL: 2110 to 2170 | ✓ |
| 2 | UL: 1850 to 1910 | DL: 1930 to 1990 | ✓ |
| 3 | UL: 1710 to 1785 | DL: 1805 to 1880 | ✓ |
| 4 | UL: 1710 to 1755 | DL: 2110 to 2155 | ✓ |
| 5 | UL: 824 to 849 | DL: 869 to 894 | ✓ |
| 7 | UL: 2500 to 2570 | DL:2620 to 2690 | ✓ |
| 8 | UL: 880 to 915 | DL: 925 to 960 | ✓ |
| 9 | UL: 1749.9 to 1784.9 | DL: 1844.9 to 1879.9 | ✓ |
| 11 | UL: 1427.9 to 1447.9 | DL: 1475.9 to 1495.9 | ✓ |
| 12 | UL: 699 to 716 | DL: 729 to 746 | ✓ |
| 13 | UL: 777 to 787 | DL: 746 to 756 | ✓ |
| 14 | UL: 788 to 798 | DL: 758 to 768 | ✓ |
| 17 | UL: 704 to 716 | DL: 734 to 746 (LTE only) | ✓ |
| 18 | UL: 815 to 830 | DL: 860 to 875 (LET only) | ✓ |
| 19 | UL: 830 to 845 | DL: 875 to 890 | ✓ |
| 20 | UL: 832 to 862 | DL: 791 to 821 | ✓ |
| 21 | UL: 1447.9 to 1462.9 | DL: 1495.9 to 1510.9 | ✓ |
| 22 | UL: 3410 to 3490 | DL: 3510 to 3590 | ✗ |
| 23 | UL:2000 to 2020 | DL: 2180 to 2200 (LTE only) | ✓ |
| 24 | UL:1625.5 to 1660.5 | DL: 1525 to 1559 (LTE only) | ✓ |
| 25 | UL: 1850 to 1915 | DL: 1930 to 1995 | ✓ |
| 26 | UL: 814 to 849 | DL: 859 to 894 | ✓ |
| 27 | UL: 807 to 824 | DL: 852 to 869 (LTE only) | ✓ |
| 28 | UL: 703 to 748 | DL: 758 to 803 (LTE only) | ✓ |
| 29 | UL: - | DL: 717 to 728 (LTE only) | ✓ |
| 30 | UL: 2305 to 2315 | DL: 2350 to 2360 (LTE only) | ✓ |
| 31 | UL: 452.5 to 457.5 | DL: 462.5 to 467.5 (LTE only) | ✗ |
| 32 | UL: - | DL: 1452 - 1496 | ✓ |
| 35 | | 1850 to 1910 | ✓ |
| 38 | | 2570 to 2620 | ✓ |
| 39 | | 1880 to 1920 | ✓ |
| 40 | | 2300 to 2400 | ✓ |
| 41 | | 2496 to 2690 | ✓ |
| 42 | | 3400 to 3600 | ✗ |
| 43 | | 3600 to 3800 | ✗ |

3. Antenna Parameters

3.1. Return Loss

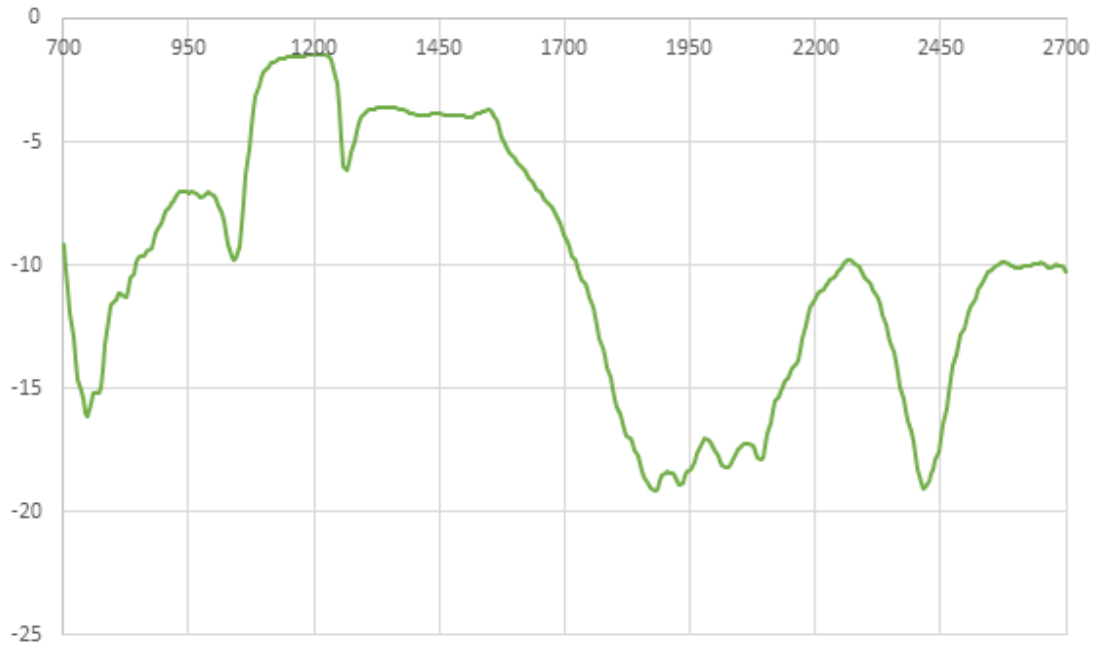

3.2. VSWR



3.3. Efficiency

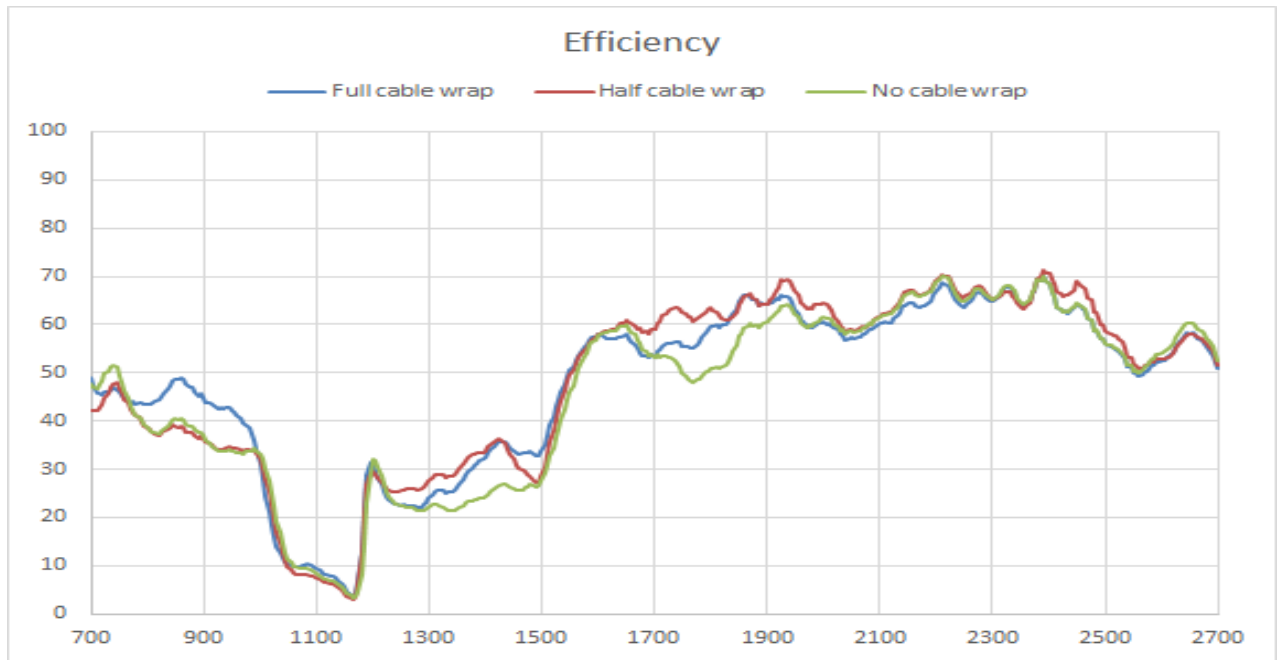

3.4. Peak Gain

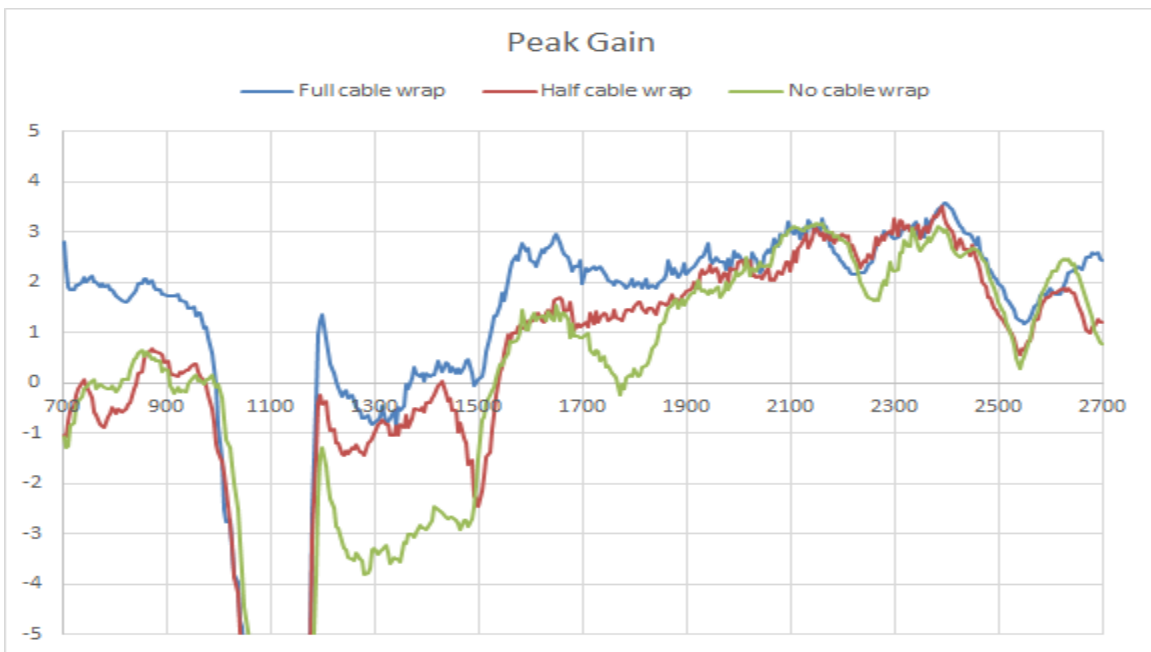

3.5. Average Gain

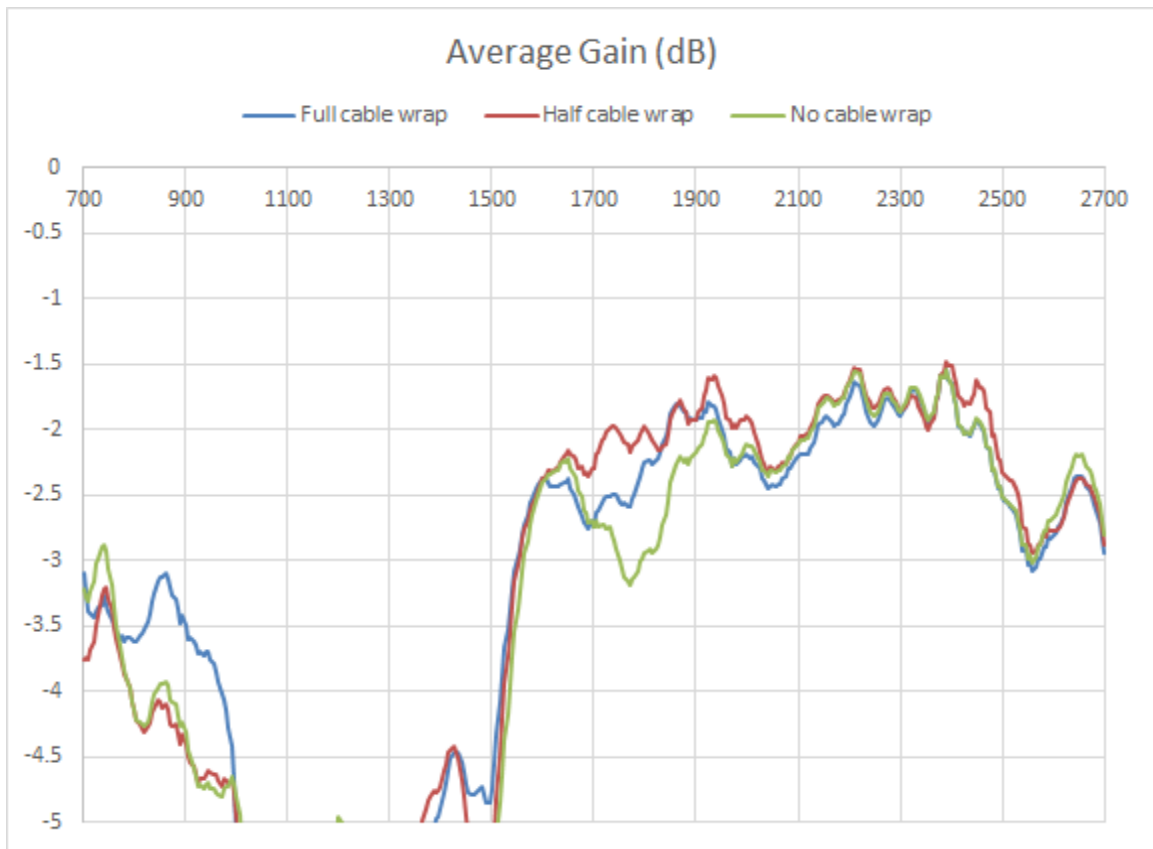

4. Radiation Pattern

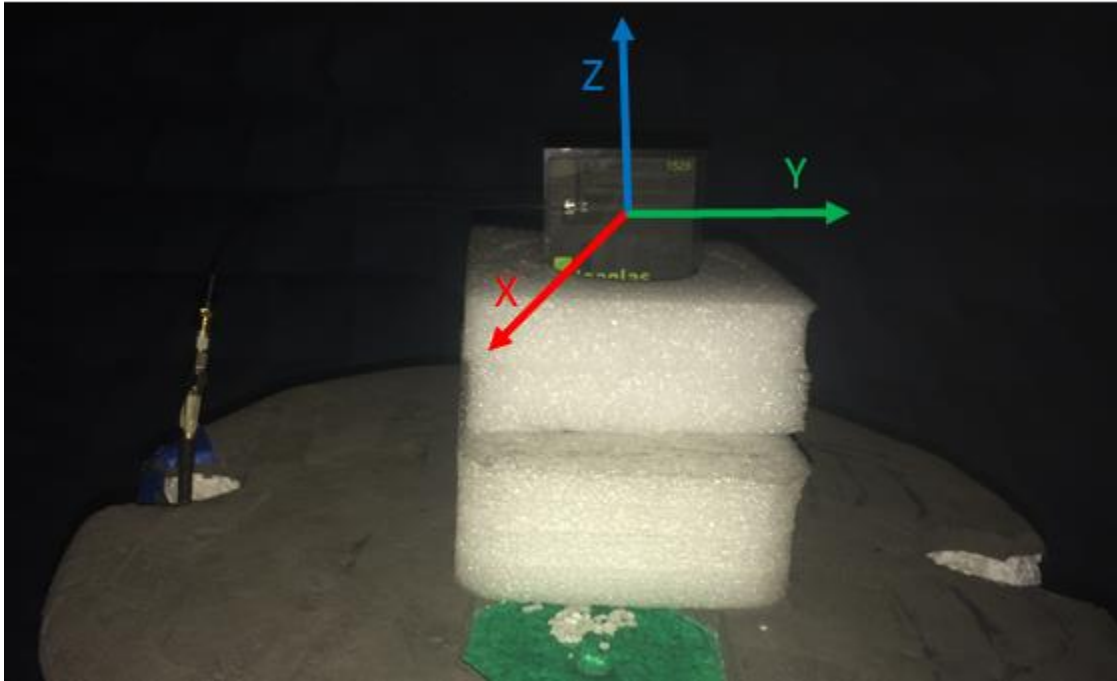

700 MHz

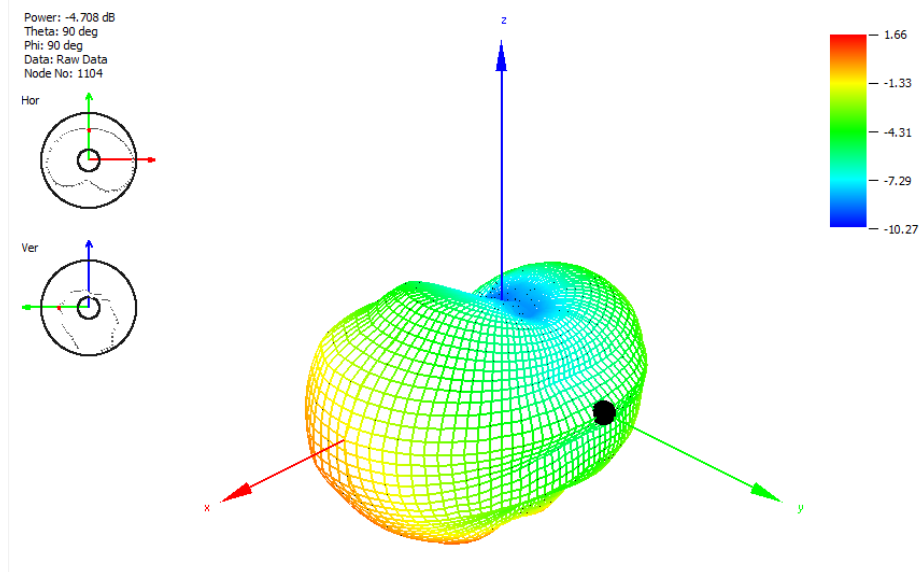

850 MHz

Power: -5.631 dB
Theta: 90 deg
Phi: 93.75 deg
Data: Double Interpolatio
Node No: 1149

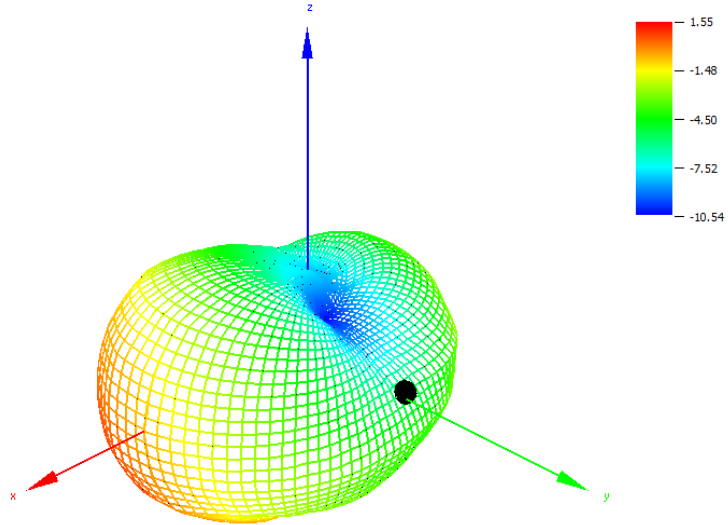
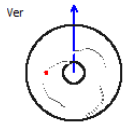
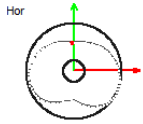

950 MHz

Power: -6.717 dB
Theta: 90 deg
Phi: 90 deg
Data: Raw Data
Node No: 1104

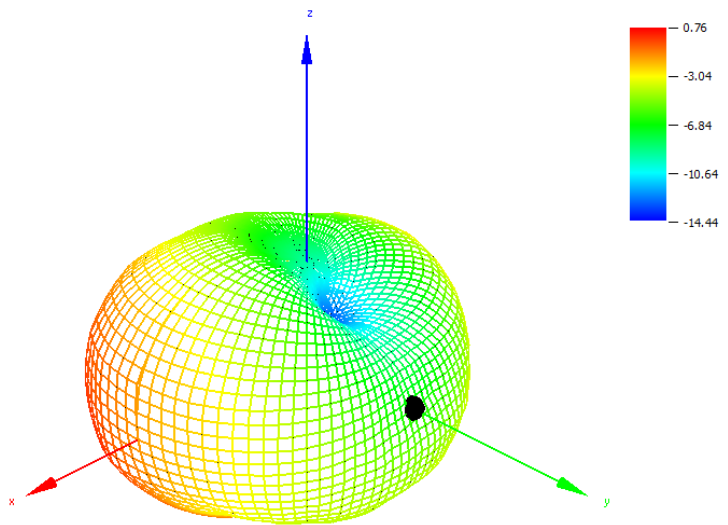
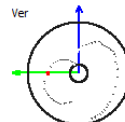
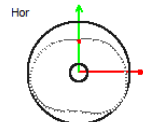

1750 MHz

Power: -4.315 dB
Theta: 90 deg
Phi: 90 deg
Data: Raw Data
Node No: 1104

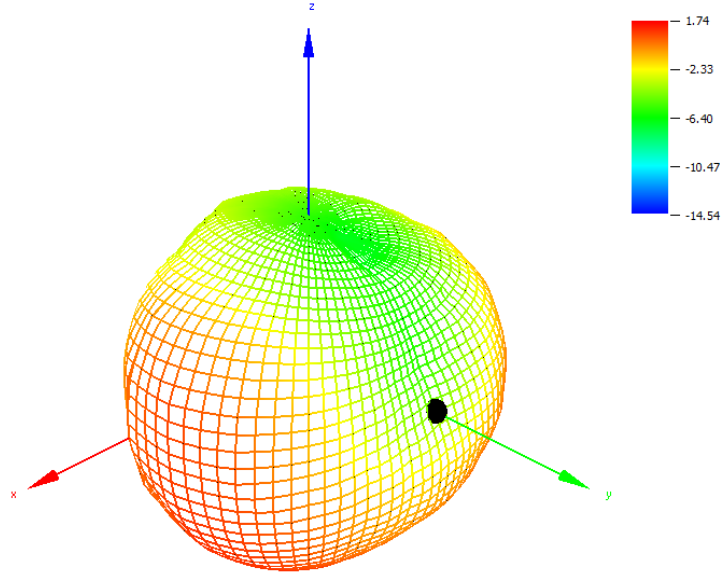
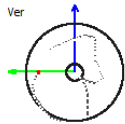
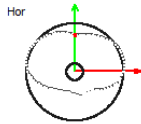

1850 MHz

Power: -2.641 dB
Theta: 90 deg
Phi: 90 deg
Data: Raw Data
Node No: 1104

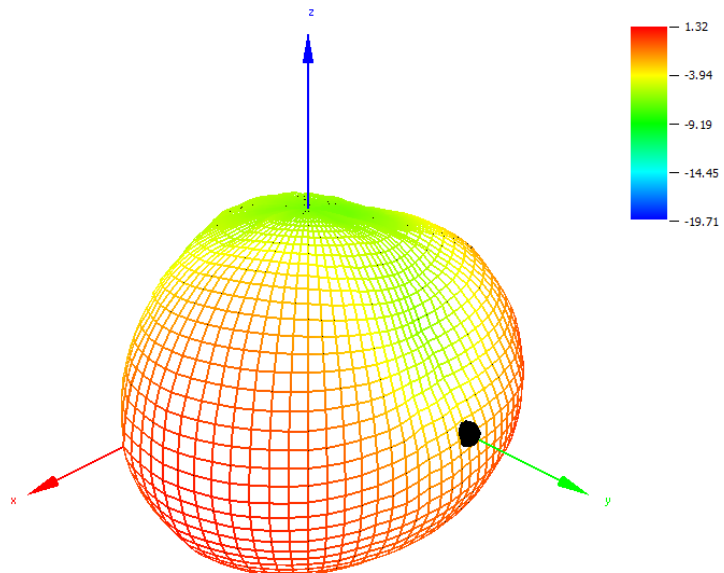
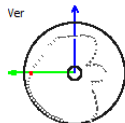
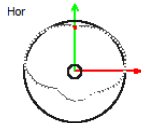

2000 MHz

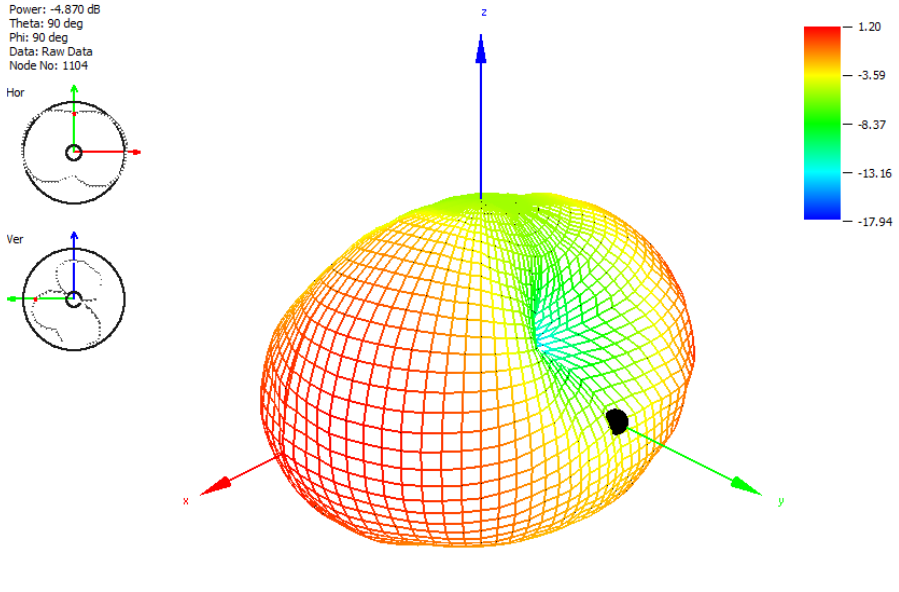

2150 MHz

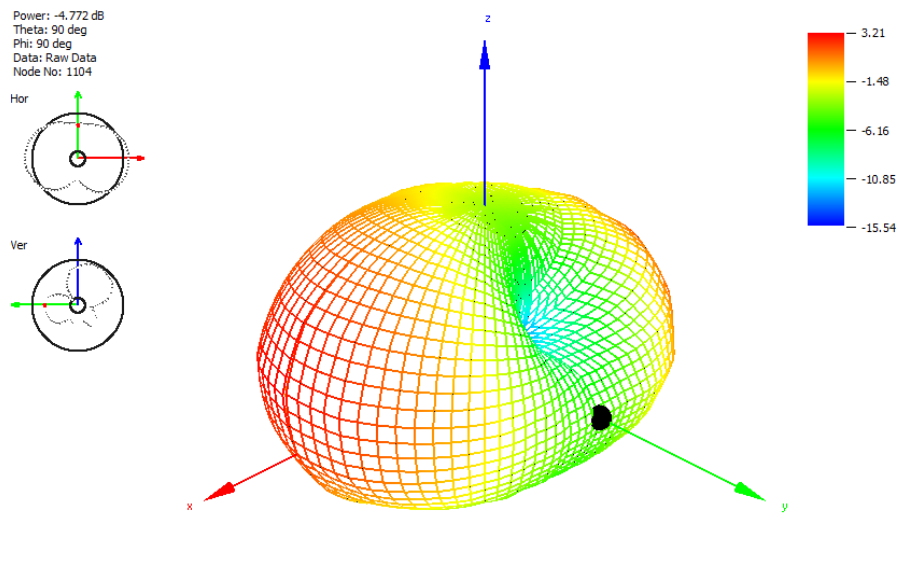

2450 MHz

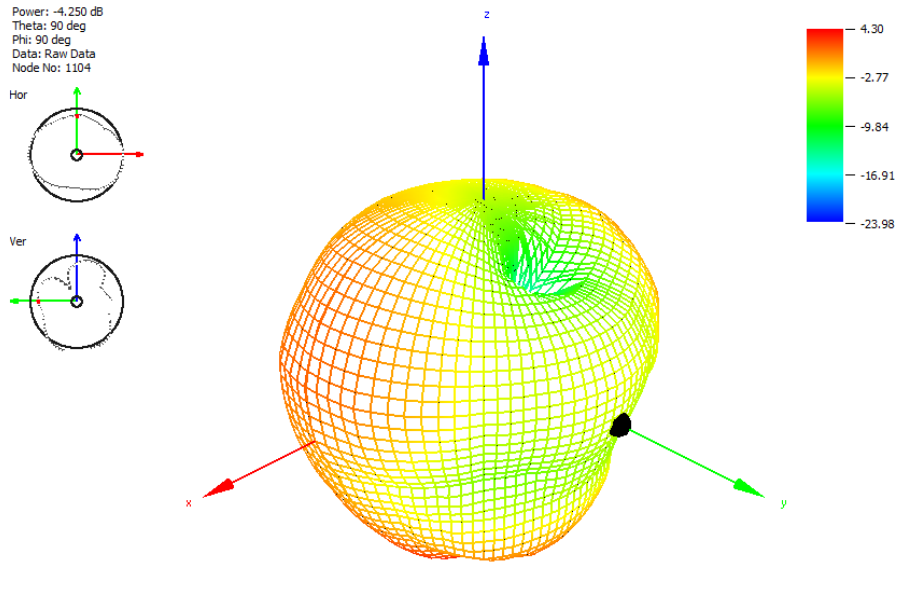

2600 MHz

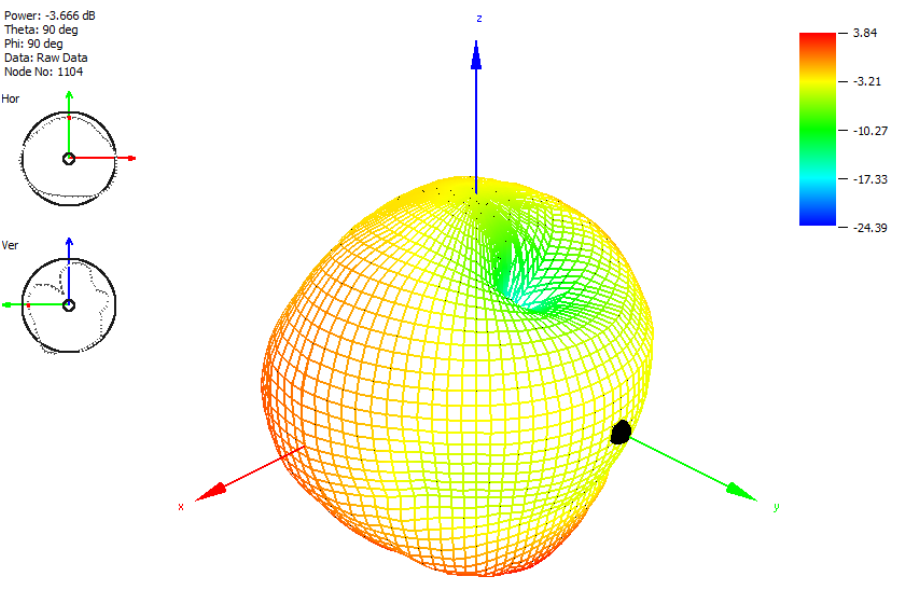

5. Mechanical Drawing (Units: mm)

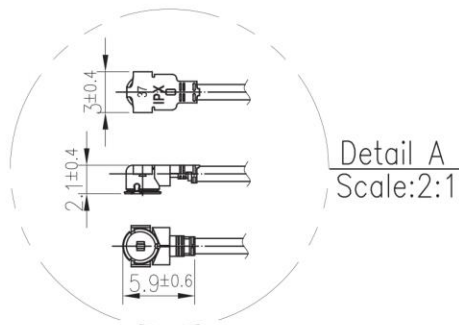
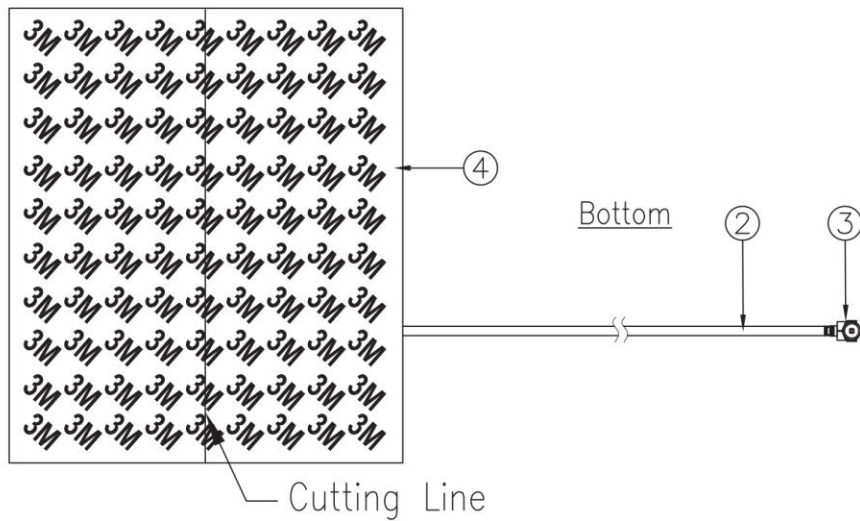
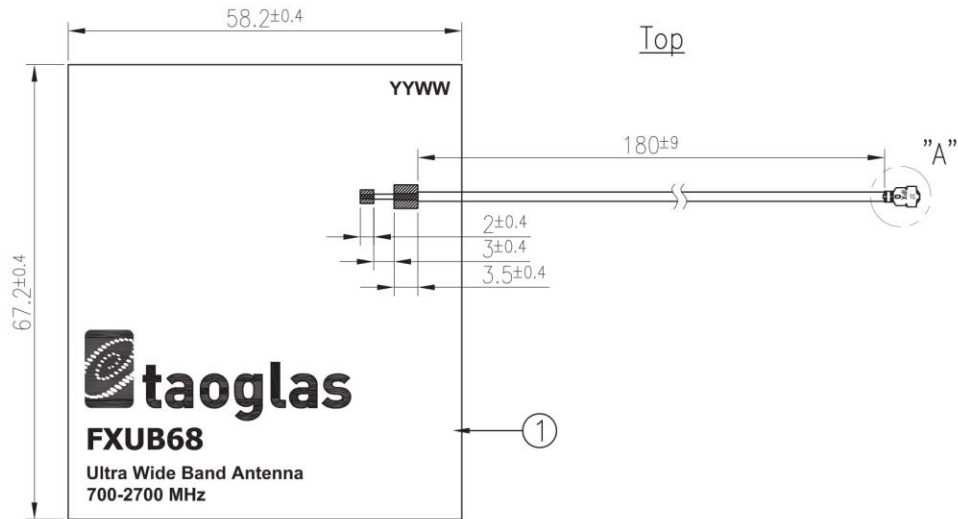

| | Name | Material | Finish | QTY |
|---|-----------------------|----------|-------------|-----|
| 1 | FXUB68 FPCB | Polymer | Black | 1 |
| 2 | 1.37 Coaxial Cable | FEP | Black | 1 |
| 3 | IPEX MHFHT | Brass | Gold | 1 |
| 4 | Double-Sided Adhesive | 3M 467 | Brown Liner | 1 |

6. Packaging

100pcs FXUB68.07.0180C per PE Bag
Bag Dimensions - 300 x 160mm
Weight - 241g

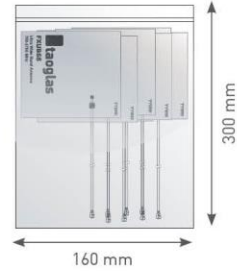

1000pcs FXUB68.07.0180C per PE Large Bag
Bag Dimensions - 380 x 280mm
Weight - 2.6kg

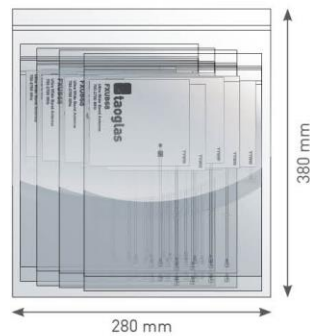

5,000 pcs FXUB68.07.0180C per carton
Carton - 320 x 250 x 230mm
Weight - 13.5Kg

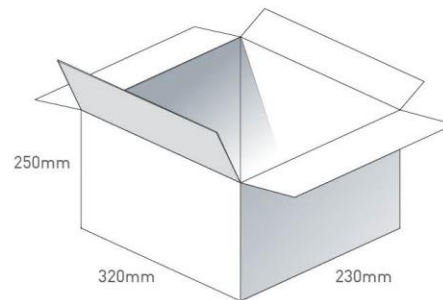

Pallet Dimensions 960 x 1000 x 1300mm
60 Cartons per Pallet
12 Cartons per layer
5 Layers

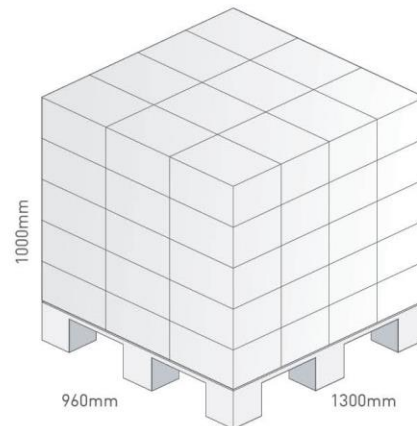

7. Application Note

Like all flex antennas, the FXUB68 Minima antenna performance is somewhat sensitive to the routing of the cable during integration. The preferred routing is a “full wrap” or “half wrap”, as shown below where the cable is routed around the long side of the device. Routing over the lower part of the device as shown will also work well. An integration where the cable runs straight off will work, but the performance in the 900MHz band may not be optimal. Avoid running the cable up along the short side or wrapping it around the short side, as these will not work. If a longer cable is needed to wrap around the long side and still reach the module, this is ok, and a longer cable can be easily built. Keep the antenna at least 20mm away from conductors in the end user device.

The FXUB68 can be integrated into assemblies over a small ground plane such as a PCB. The efficiency in these cases can sometimes be higher than the antenna alone.

Preferred Routing



Preferred Routing

Acceptable Routing



Avoid this Type of Routing:

